

12 LEVEL II es

AD A103071

# Technical



# Note

TN no. N-1596

**title:** A MAKE/BUY DECISION ANALYSIS AND ITS COMPUTER PROGRAM FOR OPTIMIZATION OF COGENERATION PLANT OPERATION AT NAVAL SUBMARINE BASE, NEW LONDON, CONNECTICUT

**author:** T. Y. Richard Lee, Ph D

**date:** November 1980

**sponsor:** Naval Material Command

**program nos:** Z0371-01-141C

DTIC  
ELECTE  
AUG 19 1981  
S B D

DTIC FILE COPY



## CIVIL ENGINEERING LABORATORY

NAVAL CONSTRUCTION BATTALION CENTER  
Port Hueneme, California 93043

Approved for public release; distribution unlimited.

81 8 19 070

Unclassified

SECURITY CLASSIFICATION OF THIS PAGE (When Data Entered)

REPORT DOCUMENTATION PAGE		READ INSTRUCTIONS BEFORE COMPLETING FORM
1. REPORT NUMBER TN-1596	2. GOVT ACCESSION NO. DN987115	3. RECIPIENT'S CATALOG NUMBER AD A103 071
4. TITLE (and Subtitle) A MAKE/BUY DECISION ANALYSIS AND ITS COMPUTER PROGRAM FOR OPTIMIZATION OF COGENERATION PLANT OPERATION AT NAVAL SUBMARINE BASE, NEW LONDON, CONNECTICUT	5. TYPE OF REPORT & PERIOD COVERED Final; Sep 79 - May 80	
	6. PERFORMING ORG. REPORT NUMBER	
7. AUTHOR(s) T. Y. Richard Lee, Ph D	8. CONTRACT OR GRANT NUMBER(s)	
9. PERFORMING ORGANIZATION NAME AND ADDRESS CIVIL ENGINEERING LABORATORY Naval Construction Battalion Center Port Hueneme, California 93043	10. PROGRAM ELEMENT PROJECT, TASK AREA & WORK UNIT NUMBERS Z0371-01-141C	
11. CONTROLLING OFFICE NAME AND ADDRESS Naval Material Command Washington, DC 20360	12. REPORT DATE November 1980	
	13. NUMBER OF PAGES 50	
14. MONITORING AGENCY NAME & ADDRESS (if different from Controlling Office)	15. SECURITY CLASS. (of this report) Unclassified	
	15a. DECLASSIFICATION DOWNGRADING SCHEDULE	
16. DISTRIBUTION STATEMENT* (of this Report)  Approved for public release; distribution unlimited.		
17. DISTRIBUTION STATEMENT (of the abstract entered in Block 20, if different from Report)		
18. SUPPLEMENTARY NOTES		
19. KEY WORDS (Continue on reverse side if necessary and identify by block number) Cogeneration, optimization, computer program, energy steam turbine/generator		
20. ABSTRACT (Continue on reverse side if necessary and identify by block number) This report illustrates that cogeneration plant operation can be optimized through the use of a hand-held programmable calculator. The cogeneration system consisting of four high-pressure steam-generating units and three turbine generators at U. S. Naval Submarine Base, New London, CT is analyzed. A computer program written for use on a TI-59 programmable calculator is therefore developed to provide the personnel of the power plant a rapid determination of the optimum operating settings for the turbine/generator sets at any		

DD FORM 1 JAN 73 1473 EDITION OF 1 NOV 65 IS OBSOLETE

continued

Unclassified  
SECURITY CLASSIFICATION OF THIS PAGE (When Data Entered)

511111

Unclassified

SECURITY CLASSIFICATION OF THIS PAGE (When Data Entered)

20. Continued

given time. Economic figures are presented to emphasize that the implementation of this program would result in significant improvements in economics and efficiency of the cogeneration process as the fuel price is expected to increase more rapidly than the utility rate. Although this computer program is initially developed for the application at SUBASE, New London, CT, its applicability to other similar cogeneration systems can be achieved by simple modification of the site-specific, sub-routine functions.

Library Card

Civil Engineering Laboratory  
A MAKE/BUY DECISION ANALYSIS AND ITS COMPUTER  
PROGRAM FOR OPTIMIZATION OF COGENERATION PLANT  
OPERATION AT NAVAL SUBMARINE BASE, NEW LONDON,  
CONNECTICUT (Final) by T. Y. Richard Lee, Ph D  
TN-1596 50 pp illus November 1980 Unclassified

1. Cogeneration

2. Computer program

I. Z0371-01-141C

This report illustrates that cogeneration plant operation can be optimized through the use of a hand-held programmable calculator. The cogeneration system consisting of four high-pressure steam-generating units and three turbine generators at U. S. Naval Submarine Base, New London, CT is analyzed. A computer program written for use on a TI-59 programmable calculator is therefore developed to provide the personnel of the power plant a rapid determination of the optimum operating settings for the turbine/generator sets at any given time. Economic figures are presented to emphasize that the implementation of this program would result in significant improvements in economics and efficiency of the cogeneration process as the fuel price is expected to increase more rapidly than the utility rate. Although this computer program is initially developed for the application at SUBASE, New London, CT, its applicability to other similar cogeneration systems can be achieved by simple modification of the site-specific, sub-routine functions.

Unclassified

SECURITY CLASSIFICATION OF THIS PAGE (When Data Entered)

CONTENTS

	Page
INTRODUCTION . . . . .	1
SYSTEM DESCRIPTION . . . . .	2
SELF-GENERATION ANALYSIS . . . . .	3
PURCHASED POWER ANALYSIS . . . . .	7
OPTIMUM MAKE/BUY DECISION ANALYSIS . . . . .	10
COMPUTER PROGRAMS. . . . .	11
Program Description . . . . .	11
Operating Instructions . . . . .	13
CONCLUSIONS. . . . .	18
RECOMMENDATIONS. . . . .	19

Accession For	
NTIS GSAR1	<input checked="" type="checkbox"/>
DTIC TAB	<input type="checkbox"/>
Unannounced	<input type="checkbox"/>
Justification	
Project	
Number/	
Availability Codes	
Announced/er	
Distribution	
A	

## INTRODUCTION

The importance of cogeneration has been greatly emphasized as the cost of energy has increased. The cost of purchased electrical power has, of course, risen with fuel prices. The increases in investment cost for power-producing equipment have forced utility companies to develop new rate structures which emphasize the reduction of reserve capacity by severely penalizing peak usage. All this has resulted in careful reviews of internal power-generating capabilities.

Currently, the U.S. Navy has approximately 12 operational steam-electric power plants with extraction turbines. They are operating in parallel with the utility company serving the area. These plants are representative of numerous small industrial turbine facilities that are capable of practicing cogeneration. A major concern in the cogenerating power plant has been that the operation of the extraction steam turbine electric plants, generally based on operator's judgments, may fail to achieve maximum economy in power usage at Naval installations. At some arbitrary control settings, or in response to a demand level at which peak shaving is initiated, some electrical power for the activity is "bought" from a utility company and some power is "made" onsite. This combination of purchased versus self-generated power may not result in the least cost power mix as power demand and steam loads vary.

The need for a means of determining the optimum economic mix of self-generated and purchased power in a plant that cogenerates steam and electricity has long been recognized by the U.S. Navy. In view of the possible near-term benefits which can be derived, the Civil Engineering Laboratory (CEL) was funded to develop a computer program. This computer program will provide the plant operator with a method of rapid determination of the optimum make/buy operating decisions for the Navy's existing automatic extraction steam turbine/generator cogenerating plants. The objectives of the study are to:

1. Select a potential Naval demonstration site (U.S. Naval Submarine Base (SUBASE) at New London, Conn. was selected).

2. Develop an algorithm for determining the cost of self-generated electricity.

3. Formulate the site-specific functions for determining the cost of purchased power.

4. Develop a computer program, based upon the above results, for use on the Texas Instruments TI-59 programmable calculator with printer for determining the most economical mix of self-generated and purchased electricity.

5. Provide user with instruction on the use of the computer program.

Although the computer program presented in the report is developed for the application at SUBASE, New London, Conn., it can be modified according to site-specific information, such as the system characteristics and utility rate structure, for the application at other Navy activities with installed steam turbine/generator equipment.

The assistance and cooperation of personnel at the Public Works Office at SUBASE, New London, Conn. is greatly appreciated, particularly that of CDR James C. Hay, LCDR Alan H. Burkett, and Mr. Max C. Browning. Special recognition is given to LCDR Alan Burkett, CEC, USN, for his assistance in optimizing the computer programs for both user convenience and run speed.

#### SYSTEM DESCRIPTION

The cogeneration system at SUBASE, New London, Conn. is depicted in Figure 1. It consists of four high-pressure steam-generating boilers and three turbine generators. All of the boilers, each rated at 76,500 pounds of steam per hour, are fueled with No. 6 oil and supply steam to 600-psig headers which are interconnected by crossties. Steam in the 600-psig header is usually heated to about 700°F. Boiler no. 1S

is a newer boiler than the other three. The overall efficiency of these boilers is assumed to be 72%. The makeup for all heat balances is assumed to lie between 17 and 19% of steam generated by the boilers, and 3% of this is assumed to be blowdown. The majority of the losses represented by the difference between the makeup and the blowdown is assumed to be lost in the export system.

All three turbines are condensing units with automatic extraction. Manufacture information for the turbine/generator sets is listed in Table 1. Turbines no. 3 (TG3) and no. 5 (TG5) receive throttle steam of 600 psi, 700°F from the boilers and both extract 200-psig, 500°F steam for the header to turbine no. 4 (TG4), to the steam-driven power plant auxiliaries, and to the 200-psig export supply. The 5-psig steam is supplied by the bleed from the 5-psig extraction ports of turbines no. 3 and no. 4. A pressure-reducing valve (PRV) and a desuperheater (DSPH) station are piped between the 600- and 200-psig headers for the direct-pressure reduction purpose. There is normally sufficient extraction steam capacity in the turbines so that the PRV can remain closed. If, for any reason, the steam pressure in the 200-psig header drops below the limit, the PRV will open to maintain the header pressure. Performance curves for the three turbines are shown in Figures 2 to 4 from which the overall turbogenerator efficiencies are estimated and listed in Table 1.

The self-generated power onsite and the purchased power from the Groton City Utility Company are connected in parallel to supply the switchgear in the power plant.

#### SELF-GENERATION ANALYSIS

The algorithms to be employed to calculate the cost of electrical power generated by the cogenerators onsite are presented in this section.

Considering each turbine/generator set shown in Figure 1 as a control volume, equations which represent the conservations of mass and energy principles can be written as follows:

Continuity equation:

$$\text{For TG3: } M_{3T} = M_{3H} + M_{3L} + M_{3E} \quad (1)$$

$$\text{For TG4: } M_{4T} = M_{4L} + M_{4E} \quad (2)$$

$$\text{For TG5: } M_{5T} = M_{5H} + M_{5E} \quad (3)$$

First law of thermodynamics:

$$\begin{aligned} \text{For TG3: } \frac{W_3 \times 3413}{E_{3T}} &= (M_{3T} \times H_{3T}) - (M_{3H} \times H_{3H}) \\ &\quad - (M_{3L} \times H_{3L}) - (M_{3E} \times H_{3E}) \end{aligned} \quad (4)$$

$$\begin{aligned} \text{For TG4: } \frac{W_4 \times 3413}{E_{4T}} &= (M_{4T} \times H_{4T}) - (M_{4L} \times H_{4L}) \\ &\quad - (M_{4E} \times H_{4E}) \end{aligned} \quad (5)$$

$$\begin{aligned} \text{For TG5: } \frac{W_5 \times 3413}{E_{5T}} &= (M_{5T} \times H_{5T}) - (M_{5H} \times H_{5H}) \\ &\quad - (M_{5E} \times H_{5E}) \end{aligned} \quad (6)$$

The explanation of the symbols used in the above-mentioned equations and in Figure 1 is presented in the Nomenclature List.

Combining these equations gives:

$$\begin{aligned} \left( \frac{W_3}{E_{3T}} + \frac{W_4}{E_{4T}} + \frac{W_5}{E_{5T}} \right) 3413 &= (M_{3H} + M_{3L} + M_{3E}) H_{3T} + (M_{4L} + M_{4E}) H_{4T} \\ &\quad + (M_{5H} + M_{5E}) H_{5T} - (M_{3H} \times H_{3H}) \\ &\quad - (M_{3L} \times H_{3L}) - (M_{3E} \times H_{3E}) \\ &\quad - (M_{4L} \times H_{4L}) - (M_{4E} \times H_{4E}) \\ &\quad - (M_{5H} \times H_{5H}) - (M_{5E} \times H_{5E}) \end{aligned} \quad (7)$$



Assuming that the piping losses are negligible, then

$$H_{3T} = H_{5T} = H_S \quad (8)$$

$$H_{3H} = H_{5H} = H_{4T} = H_H \quad (9)$$

$$H_{3L} = H_{4L} = H_L \quad (10)$$

Substitution of these relations along with the following identities

$$M_{4L} (H_H - H_L) = M_{4L} (H_S - H_L) - M_{4L} (H_S - H_H)$$

and

$$M_{4E} (H_H - H_{4E}) = M_{4E} (H_S - H_{4E}) - M_{4E} (H_S - H_H)$$

into Equation (7) yields:

$$\begin{aligned} \left( \frac{W_3}{E_{3T}} + \frac{W_4}{E_{4T}} + \frac{W_5}{E_{5T}} \right) 3413 &= (M_{3H} + M_{5H} - M_{4T})(H_S - H_H) \\ &+ (M_{3L} + M_{4L})(H_S - H_L) \\ &+ M_{3E}(H_S - H_{3E}) + M_{4E}(H_S - H_{4E}) \\ &+ M_{5E}(H_S - H_{5E}) \end{aligned} \quad (11)$$

From the heat balance of this system, it has been found\* that the quantity of the 5-psig steam, to be supplied to the deaerator, is about the same as that to be exhausted from the three steam-driven auxiliaries as shown in Figure 1. Therefore, it is reasonable to assume that  $M_{3L} + M_{4L}$  is equal to  $M_L$ , the low-pressure export steam.

Assume that the amount of steam consumed for steam-driven auxiliaries between the 200-psig and the 5-psig headers is negligible compared with high-pressure export steam  $M_H$ . The term  $(M_{3H} + M_{5H} - M_{4T})$  in Equation 11 will be equal to the high-pressure export steam supply  $M_H$ . In addition, it is reasonable to assume that

---

\*Carlson & Sweatt Engineers. "Report on economics of electrical power generation," New York, N.Y., Aug 1972. (Prepared for Naval Submarine Base, New London, Conn.)

$$H_S - H_{3E} \doteq H_S - H_{4E} \doteq H_S - H_{5E}$$

With the above-mentioned assumptions, Equation 11 can be rewritten as

$$\left( \frac{W_3}{E_{3T}} + \frac{W_4}{E_{4T}} + \frac{W_5}{E_{5T}} \right) 3413 = M_H (H_S - H_H) + M_L (H_S - H_L) + (M_{3E} + M_{4E} + M_{5E}) (H_S - H_E) \quad (12)$$

Where  $H_E$  is defined as the enthalpy of the mixed exhaust steam, and  $M_{3E} + M_{4E} + M_{5E}$  is the total condensing steam flow of this system with the limit value of  $M_{3M} + M_{4M} + M_{5M}$ .

Up to this point, Equation 12 has been derived for the total thermal energy to be converted into the predetermined electrical power,  $W_3 + W_4 + W_5$ , while meeting the steam load demand at any given time.

In order to compute the cost for the electricity generated onsite, the turbine heat rate ( $T_{HR}$ ) is determined and used as follows:

Total energy added to turbines:

$$(M_{3T} + M_{4T}) H_S$$

The thermal energy which is recoverable from the turbine system:

$$M_H \times H_H + M_L \times H_L + (M_{3E} + M_{4E} + M_{5E}) \times H_C$$

Where  $H_C$  is the average enthalpy value of the condensate from turbines.

The turbine heat rate ( $T_{HR}$ ) is the net heat input to the turbines per unit of electrical generated, which can be written as:

$$T_{HR} = [(M_{3T} + M_{5T}) H_S - (M_H \times H_H) - (M_L \times H_L) - (M_{3E} + M_{4E} + M_{5E}) H_C] / (W_3 + W_4 + W_5) \quad (13)$$

Substitution of Equation (12) into Equation (13) leads to

$$\begin{aligned}
 T_{HR} = & \left[ (W_3/E_{3T}) + (W_4/E_{4T}) + (W_5/E_{5T}) \right] 3413 \\
 & + (M_{3E} + M_{4E} + M_{5E}) (H_E - H_C) + (W_3 \\
 & + W_4 + W_5)
 \end{aligned}
 \tag{14}$$

Where the turbine heat rate,  $T_{HR}$ , in unit of Btu per kW-hr, is the instantaneous heat rate derived from a particular heat balance of the overall cogenerating system at a fixed-load situation.

Examination of Equation 14 indicates that it will be more efficient to generate electricity onsite when the system is operating at the minimum allowable condensing level, i.e., when  $(M_{3E} + M_{4E} + M_{5E})$  is minimum. It is, therefore, the objective of this study to seek an optimal balance between the power demand set point and the operation of the three condensing turbines.

With the information available for the heating value of fuel, fuel price and boiler efficiency, the cost of self-generation of  $W_T (= W_3 + W_4 + W_5)$  electrical power at any expected export steam loads,  $M_H$  and  $M_L$  can be expressed as follows:

Unit cost of self-generation,  $\text{¢/kW-hr}$  is

$$C_{US} = T_{HR} \times P_F / (H_V \times E_B)
 \tag{15}$$

Total cost of self-generated electricity,  $W_3 + W_4 + W_5$ , over the time period of  $T$  hours (which may be a period of one shift or less) is

$$C_{TS} = C_{US} \times (W_3 + W_4 + W_5) \times T
 \tag{16}$$

#### PURCHASED POWER ANALYSIS

The SUBASE at New London, Conn. purchases part of its electrical power from the Department of Utilities of the City of Groton. The rate structure, presented in Table 2, includes two charges during the 30-day

billing period: the demand charge and the energy charge. The energy charge is simply a predetermined price per kW-hr used. The price can vary with the amount purchased, but basically it is a straightforward cost. The demand charge is currently established as a predetermined price times the highest peak value created over the last 11 months. The demand charge represents a very significant part (about 25%) of the total utility bill. In such a structure, the demand charge becomes almost like a fixed cost, which has to be paid whether it is utilized or not. Each bill for the current month will be increased or decreased by an amount equal to the fuel adjustment factor ( $F_A$ ) times the total energy (kW-hr) used in the current billing month.

The cost of the purchased electricity over the time period, T, during the billing month is calculated according to the rate structure listed in Table 2 as follows

(i) The demand charge, \$/kW-hr:

$$4.72/(30 \times 24)$$

(ii) The energy charge, \$:

$$(0.0343 + F_A) R_1 + (0.0269 + F_A) R_2 + (0.0211 + F_A) R_3$$

The values of coefficients  $R_1$ ,  $R_2$  and  $R_3$  are dependent upon the values of the cumulative energy consumption at the beginning ( $K_1$ ), and that at the end ( $K_2$ ) of the time period, T. The relation between  $K_1$  and  $K_2$  can be presented as

$$K_2 - K_1 = K_p \times T$$

Where  $K_p$  represents the electrical power to be purchased during time period, T, from the utility company.

These coefficients  $R_1$ ,  $R_2$  and  $R_3$  are to be determined according to the following conditions:

$$(1) K_2 < 50,000$$

$$R_1 = K_P \times T$$

$$R_2 = R_3 = 0$$

$$(2) 50,000 < K_2 < 300 \times D_U$$

$$(a) K_1 < 50,000$$

$$R_1 = 50,000 - K_1$$

$$R_2 = K_2 - 50,000$$

$$R_3 = 0$$

$$(b) K_1 > 50,000$$

$$R_2 = K_P \times T$$

$$R_1 = R_3 = 0$$

$$(3) 300 \times D_U < K_2$$

$$(a) K_1 < 50,000$$

$$R_1 = 50,000 - K_1$$

$$R_2 = 300 \times D_U - 50,000$$

$$R_3 = K_2 - 300 \times D_U$$

$$(b) 50,000 < K_1 < 300 \times D_U$$

$$R_1 = 0$$

$$R_2 = 300 \times D_U - K_1$$

$$R_3 = K_2 - 300 \times D_U$$

$$(c) 300 \times D_U < K_1$$

$$R_1 = R_2 = 0$$

$$R_3 = K_P \times T$$

Thus, the total cost ( $C_{TP}$  in dollars) for the purchased utility ( $K_P$ ) over the period,  $T$ , is

$$C_{TP} = (0.0343 + F_A) R_1 + (0.0269 + F_A) R_2 + (0.0211 + F_A) R_3 + [4.72/(30 \times 24)] \times D_U \times T \quad (17)$$

And the unit cost of utility ( $C_{UP}$  in ¢/kW-hr) for the purchased power ( $K_p$ ) is

$$C_{UP} = [C_{TP}/(K_p \times T)] \times 100 \quad (18)$$

#### OPTIMUM MAKE/BUY DECISION ANALYSIS

When there is a combination of self-generation and purchase of electrical power, the total unit cost (in cents per kW-hr) can be expressed as:

$$C_U = \frac{C_{TS} + C_{TP}}{D \times T} \quad (19)$$

Where  $C_{TS}$  and  $C_{TP}$ , the total costs of self-generation and purchase power, respectively, have been derived in the preceding sections. It is evident from Equations 16 and 17 that at the specified demands of power and steam, both  $C_{TS}$  and  $C_{TP}$  are a function of the total self-generation onsite,  $W_T (= W_3 + W_4 + W_5)$ . Thus, Equation 19 can be written mathematically as:

$$C_U (W_T) = C_{TS}(W_T) + C_{TP}(W_T) \quad (19-1)$$

A realistic problem of this combination, Make versus Buy, which has been encountered by plant operators, is how much power ought to be generated onsite in order to meet the requirements at the lowest cost. In order to solve this optimization problem, which is the objective of this study, it is necessary to select the optimum value of self-generation,  $W_T$ , to minimize the total unit cost derived from Equation 19. A necessary condition for a minimum value of  $C_U$  to exist is that:

$$\frac{dC_U (W_T)}{dW_T} = 0 \quad (19-2)$$

This is done here numerically, using a hand-held programmable calculator, in accordance with the following operational limits for the system:

- Maximum extraction flow for each steam turbine
- Minimum condensing flow for each steam turbine
- Limits for turbine/generator power output

It should be noted that the solution of  $C_U$  determined from Equation 19 may not be minimum where Equation 19-2 holds, but an optimum one with which the above-mentioned constraints comply.

The numerical procedure for determining the optimum value of unit cost,  $C_U$ , starts with the assumption that maximum possible electrical power will be generated onsite and any additional electricity will be purchased in order to meet the power demand requirement over the time period, T. The resultant unit cost,  $C_U$ , is then compared with the new value resulting from the assumption of reducing the self-generation capacity by a predetermined decrement and the increasing purchased electrical power. This iteration is continued, i.e., the assumption of generating less electricity onsite and purchasing more from the utility, until the optimum (or minimum) value of unit cost  $C_U$  is found.

## COMPUTER PROGRAMS

### Program Description

The computer programs are developed according to the analysis presented in the previous section and are designed for use on a Texas Instruments TI-59 programmable calculator with a PC-100C printer. The program can be utilized by the operators of the power plant at any time to determine the optimum mix of self-generated and purchased electrical

power at SUBASE, New London, Conn. The results of this program will provide a guideline which will enable the operators to operate the power plant in the most economical way.

A flow chart describing the logic of the computer program is shown in Figure 5. The listing of the computer program suitable for use on the Texas Instruments TI-59 programmable printing calculator appears in Table 3. The first two columns of the program listed in Table 3 are for the program location and key code, respectively. The group of three digits shows the location in program memory of each instruction. This not only allows the user to keep track of instructions, but also tells the calculator the order in which to complete the instructions. Since the calculator can only understand numbers, each key symbol on the keyboard is assigned a two-digit code number known as a key code corresponding to the instruction stored in the program memory location.

There are two groups of information required for this program to run. The first group of information is the characteristics of the onsite generating system which can be named "System Information" including the efficiencies of turbine/generator sets and boilers, the thermodynamic properties at the points of interest, and the constraints of the turbine/generator sets. All the systems' information is treated as constants and is stored at data registers 0 to 17. These values are listed in Table 4. If any change is necessary due to equipment modifications, it is relatively easy to revise the required values with a basic understanding of programming on the TI-59 calculator. It is worthwhile to mention that the constraints of the turbine/generator sets are stored with the assumption that all three sets are on-line for operation. However, the user still has the options to make his choice of any other combination of turbine/generator sets in the process of determining the optimum mix of self-generated and purchased electrical power. To assume putting an out-of-service turbine/generator set back in service, the user has to take some simple steps to restore into the data registers the constraints of the equipment before the user starts to run the program. Details of this procedure will be described later.



The second group of information, called "Operational Information," consists of ten variables. These all have to be keyed into the calculator by the user when the program is run for the first time. For subsequent runs, only those variables which are different from the previous ones need to be keyed in again with the exception that the values of  $W_3$ ,  $W_4$  and  $W_5$  have to be reentered for every run. The ten variables and their data registers are listed as follows:

- $W_3$        $R_{20}$ , highest selected electric output (kW) of TG3
- $W_4$        $R_{21}$ , highest selected electric output (kW) of TG4
- $W_5$        $R_{22}$ , highest selected electric output (kW) of TG5
- $M_H$        $R_{23}$ , high pressure (200 psig) export steam (lb/hr)
- $M_L$        $R_{24}$ , low pressure (5 psig) export steam (lb/hr)
- $D$          $R_{25}$ , electric demand (kW) during the time period, T
- $K_1$        $R_{26}$ , cumulative purchased energy (kW-hr) at the beginning of each run
- $F_A$        $R_{27}$ , fuel adjustment factor (\$/kW-hr)
- $P_F$        $R_{28}$ , fuel price (¢/gal.)
- $T$          $R_{29}$ , time period of interest (hr) for each run

All these ten inputs are stored automatically by the program into data registers 20 to 29 ( $R_{20}$ - $R_{29}$ ). The first three inputs are the selected generator outputs of turbine/generator sets, which are normally the rated capacities, with the condition that the total inputs of  $W_3$ ,  $W_4$  and  $W_5$  at any time must be either equal to or less than the input of electrical demand  $D$ .

#### Operating Instructions

A detailed explanation of how to run this program is presented in this section. A step-by-step user instruction to run the program is shown in Table 5. The explanation of each step is given below.

Step

- 1 Slide the ON/OFF switches on the TI-59 calculator and the printer to the ON positions. A single zero should be seen in the calculator display.
- 2 Read magnetic cards. The two magnetic cards used to store the program and the system information are illustrated below.

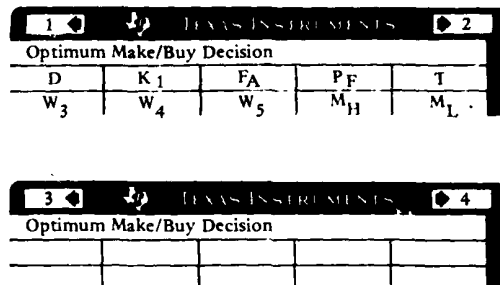

Each magnetic card is labeled according to the information stored on it. In the upper corners of each card, the number in each space is to indicate the bank numbers recorded on that card. The arrow in each space shows which direction the card must be inserted into the calculator when reading the indicated bank. The space across the center of the card is available for the program title and other pertinent information such as the required partition. Below this line are two rows of boxes. The bottom five boxes are used to indicate the function of the defined keys **A** through **E** within the recorded program. The upper row of boxes is used similarly for the keys **A'** through **E'**.

### Step

To read a magnetic card, press  and insert the card into the lower slot on the right side of the calculator. The drive motor of the calculator will automatically pull the card through the calculator. The number of the bank recorded from the entered card is shown in the display after that card side has been read successfully.

Repeat the procedure (Press  and enter a card side) until all four banks (1, 2, 3, and 4) have been correctly read (in any order).

Up to now, the computer program and the system information have been read into the calculator from the magnetic cards and will be stored in the calculator as long as the switches of the calculator and printer are left at "ON" positions continuously.

### Step

- 3 Enter numerical value for  $W_3$  as selected generator output of TG3 and press . Input will be stored into data register 20 and printed out. The decrement of input for iteration will be in the display after a very short period of computation. (During computation, a "C" appears at the left side of the otherwise blank display.)
- 4 Enter the value of  $W_4$  and press . Input will be stored into data register 21 and printed out. The decrement of input will appear in the display after a very short period of computation.
- 5 Enter the value of  $W_5$  and press . Input will be stored into data register 22 and printed out. The decrement of input will appear in the display after a very short period of computation.

Step

- 6 Enter the value of  $M_H$  and press  $\boxed{D}$ . Input in the display is stored into data register 23 and printed out.
- 7 Enter the value of  $M_L$  and press  $\boxed{E}$ . Input in the display is stored into data register 24 and printed out.
- 8 Enter the value of D and press  $\boxed{2nd} \boxed{A}$ . Input in the display is stored into data register 25 and printed out.
- 9 Enter the value of  $K_1$  and press  $\boxed{2nd} \boxed{B}$ . Input in the display is stored into data register 26 and printed out.
- 10 Enter the value of  $F_A$  and press  $\boxed{2nd} \boxed{C}$ . Input in the display is stored into data register 27 and printed out.
- 11 Enter the value of  $P_F$  and press  $\boxed{2nd} \boxed{D}$ . Input in the display is stored into data register 28 and printed out.
- 12 Enter the value of T and press  $\boxed{2nd} \boxed{E}$ . Input in the display is stored into data register 29 and printed out.

Note: If a mistake is made at any above numerical data entering step (3 to 12) simply press  $\boxed{CLR}$  and start over again for that step.

- 13 To run the program, press:  $\boxed{RST}$  ,  $\boxed{R/S}$  .

When the program is in execution, there is a blinking "C" on the left side of the otherwise blank display. The following results will be printed, successively, for the first and last iterations:

● TG3 electrical output, kW	- $W_3$
● TG4 electrical output, kW	- $W_4$
● TG5 electrical output, kW	- $W_5$
● Total condensing flow, lb/hr	- $M_C$
● Heat rate, Btu/kW-hr	- $T_{HR}$
● Unit cost of self-generation, ¢/kW-hr	- $C_{US}$
● Total cost of self-generation, \$	- $C_{TS}$
● Unit cost of purchased power, ¢/kW-hr	- $C_{UP}$
● Total cost of purchased power, \$	- $C_{TP}$
● Total cost, \$	- $C_T$
● Total unit cost, ¢/kW-hr	- $C_U$

After the last group of output is printed, the display should read "0" indicating that the program has been successfully run and has stopped. A sample printout is given in Table 6. The first outputs are the results calculated using the input values of generator outputs,  $W_3$ ,  $W_4$ , and  $W_5$  given by the user, while the last outputs are the results using the optimum self-generation solutions of  $W_3$ ,  $W_4$ , and  $W_5$ .

For repeated or subsequent runs, steps 3, 4, and 5 (for entering the values of  $W_3$ ,  $W_4$ , and  $W_5$ ) are required to be repeated whether or not the entering values are different from the previous values! However, only those steps from 6 to 12 need to be repeated for which entering values differ from the previous run. The program is then restarted by pressing   after the last value changed.

Caution: If the user has assumed that any one of the turbine/generator sets has been shut down (by entering zeros for  $W_3$ ,  $W_4$ , or  $W_5$ ) in running the program, he must read bank no. 4 of the magnetic card once again (as described in step 2) in order to restore the system information before he starts to rerun the program for a different combination of turbine/generator sets.

## CONCLUSIONS

A computer program designed for use on a hand-held TI-59 calculator, with a PC-100 printer, has been developed to provide the personnel of the power plant at SUBASE, New London, Conn., with a rapid computation of the optimum operating settings for the turbine/generator sets during any given shift. Input parameters of this computer program are left free and, for most of them, are not required to be entered for subsequent runs unless they are different from those previously entered. The most unique feature of this computer program is that it provides the user with maximum flexibility in the choice of the mode of operation of the power plant. This means that all three turbine/generator sets may be assumed online for operation, or any other combinations of one or two turbine/generators may be assumed online in the process of determining the optimum mix of self-generated and purchased electrical power.

The economics of power generation at SUBASE, New London, Conn., has changed quite drastically over the last few years due to the great increase in fuel oil costs. Since purchased power rates have not increased in the same proportion, purchased power has become more economical than onsite power generation. The dramatic influence of the rate structure and fuel price on the total unit cost is evident in Figure 6. The data selected for use in Figure 6 are shown in Table 7. As indicated in Figure 6, it would be more advantageous to the SUBASE to purchase electrical power from the utility than to generate it onsite while the prices of fuel and utilities are increasing at the same rates as before. However, due to the very nature and functioning of the SUBASE, the power supply reliability dictates a reasonable amount of base generation and spinning reserve. Therefore, generation assignments should be made in such a manner as to strike a balance between reliability requirements and economics.

The significance in savings resulting from the optimum operation of the existing cogeneration system at the SUBASE has also been changed over the years. Figure 6 shows that the operation of the power plant at the optimum make/buy ratio in 1972 was not as critical as it became in 1976 and 1979. For example, curve no. 1 illustrates that the optimum

operating point in 1972 was at a make/buy ratio 3,500 kW/11,500 kW for a given demand, 15,000 kW. Even when operating 100% off the optimum point, i.e., 7,000 kW/8,000 kW, in 1972 there would have resulted an additional total unit cost of about 0.06 cents per kW-hr. However, a similar deviation from the optimum points (100% off) for curves 2, 3 and 4 would result in additional total unit cost of 0.30, 0.40 and 0.65 cents per kW-hr respectively, the latter of which is typical of 1979. Hence, it can be concluded that more savings would be achieved by operating the existing power plant at, or close to, the determined optimum make/buy decision points as the fuel price is expected to increase continuously.

Figures 7 and 8 present the results of the parametric study of the effect of steam loads and fuel price on total unit cost, respectively. As clearly seen, the variations of steam demand will affect the location of minimum points and the total unit cost levels dramatically. However, the increase of fuel prices may not affect the locations of minimum points but would result in higher additional total unit costs if the plant was not operated at the minimum point.

#### RECOMMENDATIONS

In order to evaluate the savings resulting from the implementation of this program, a user data sheet is designed and shown in Table 8 for users to record all the relevant information. There are four columns in this user data sheet. The first column records the date and time when the operator starts to use this program. The second column is used to record the operational information. The third column is for the results printed out from the printer. The last column, which is very important for the evaluation, is for the actual information, after the fact, that will be used to calculate the costs to be compared with those in the third column.

Although the computer program developed in this study is for use at SUBASE, New London, Conn., its applicability to other Navy activities which already practice cogeneration with steam turbine/generator equipment

is recommended to be investigated by modifying this program according to the site-specific requirements, such as thermodynamic characteristics of the cogeneration system, the utility rate structure and load demands.



Table 1. Steam Turbine/Generator Ratings at SUBASE, New London, Conn.

Turbine/ Generator	Manufacture	Year Installed	Name Plate Capacity (kW)	Maximum Throttle Flow (lb/hr)	Extraction Pressure (psig)	Exhaust Pressure (in.abs)	Overall Efficiency
TG3	GE	1944	3,500	129,000	200 and 5	1.5	0.70
TG4	Elliot	1940	4,000	75,000	5	1.5	0.68
TG5	Terry	1977	5,000	160,000	200	4	0.72

Table 2. Utility Structure at SUBASE, New Longon, Conn.  
(as of April 1980)

<u>Demand Charge per Month:</u> (with .15 per kW credit)	\$4.72/kW
<u>Energy Charge:</u> (subject to 5% discount)	
First 50,000 kW-hr	\$0.0343/kW-hr
Over 50,000 kW-hr and up to 300 x billing demand	\$0.0269/kW-hr
Over 300 x billing demand	\$0.0211/kW-hr

Table 3. Listing of Make/Buy Decision Computer Program

000	40	STD	049	75	LBL
001	31	31	050	11	R
002	31	31	051	41	STD
003	75	LBL	052	20	21
004	69	OP	053	29	OP
005	43	RCL	054	22	INV
006	33	33	055	67	EQ
007	65		056	00	00
008	43	RCL	057	63	63
009	29	29	058	42	STD
010	95	=	059	11	11
011	92	RTN	060	42	STD
012	76	LBL	061	08	08
013	99	*	062	71	SBR
014	71	SBR	063	52	EE
015	09	OP	064	42	STD
016	85	+	065	30	30
017	43	RCL	066	92	RTN
018	26	26	067	76	LBL
019	75	-	068	13	B
020	43	RCL	069	42	STD
021	34	34	070	21	21
022	95	=	071	29	OP
023	92	RTN	072	22	INV
024	71	SBR	073	67	EQ
025	69	OP	074	00	00
026	85	+	075	80	80
027	43	RCL	076	42	STD
028	26	26	077	12	12
029	76	LBL	078	42	STD
030	55	+	079	09	09
031	75	-	080	71	SBR
032	05	5	081	52	EE
033	00	0	082	42	STD
034	00	0	083	31	31
035	00	0	084	92	RTN
036	00	0	085	76	LBL
037	95	=	086	13	C
038	92	RTN	087	42	STD
039	76	LBL	088	22	22
040	52	EE	089	29	OP
041	99	PRT	090	22	INV
042	65	*	091	67	EQ
043	43	RCL	092	00	00
044	17	17	093	98	98
045	65	*	094	42	STD
046	05	5	095	13	13
047	95	=	096	42	STD
048	92	RTN	097	10	10

Table 3. Continued

098	71	SBR	149	25	CLR
099	52	EE	150	92	RTN
100	42	STD	151	43	RCL
101	32	32	152	02	02
102	92	RTN	153	85	+
103	76	LBL	154	43	RCL
104	14	D	155	09	09
105	42	STD	156	85	+
106	33	33	157	43	RCL
107	99	PRT	158	10	10
108	92	RTN	159	95	=
109	76	LBL	160	42	STD
110	15	E	161	19	19
111	42	STD	162	43	RCL
112	24	24	163	02	02
113	99	PRT	164	65	X
114	92	RTN	165	43	RCL
115	76	LBL	166	23	23
116	18	B'	167	85	+
117	42	STD	168	43	RCL
118	25	25	169	02	02
119	99	PRT	170	65	X
120	92	RTN	171	43	RCL
121	76	LBL	172	24	24
122	17	B'	173	95	=
123	42	STD	174	42	STD
124	26	26	175	19	19
125	99	PRT	176	71	SBR
126	92	RTN	177	02	02
127	76	LBL	178	66	66
128	18	C'	179	43	RCL
129	42	STD	180	33	33
130	27	27	181	67	EQ
131	99	PRT	182	02	02
132	92	RTN	183	00	00
133	76	LBL	184	75	-
134	19	D'	185	43	RCL
135	42	STD	186	35	35
136	28	28	187	95	=
137	99	PRT	188	67	EQ
138	92	RTN	189	02	02
139	76	LBL	190	63	63
140	10	E'	191	94	+/-
141	42	STD	192	22	INV
142	29	29	193	77	GE
143	99	PRT	194	02	02
144	98	ADV	195	51	51
145	92	RTN	196	43	RCL
146	06	6	197	33	33
147	69	DP	198	42	STD
148	17	17	199	35	35

Table 3. Continued

200	43	RCL	251	43	RCL
201	30	30	252	30	30
202	22	INV	253	44	SUM
203	44	SUM	254	20	20
204	20	20	255	43	RCL
205	43	RCL	256	31	31
206	20	20	257	44	SUM
207	32	X:T	258	21	21
208	43	RCL	259	43	RCL
209	11	11	260	32	32
210	22	INV	261	44	SUM
211	77	GE	262	22	22
212	02	02	263	22	INV
213	16	16	264	86	STF
214	42	STD	265	05	05
215	20	20	266	43	RCL
216	43	RCL	267	20	20
217	31	31	268	85	+
218	22	INV	269	43	RCL
219	44	SUM	270	21	21
220	21	21	271	85	+
221	43	RCL	272	43	RCL
222	21	21	273	22	22
223	32	X:T	274	95	=
224	43	RCL	275	42	STD
225	12	12	276	33	33
226	22	INV	277	75	-
227	77	GE	278	43	RCL
228	02	02	279	25	25
229	32	32	280	95	=
230	42	STD	281	94	+/-
231	21	21	282	42	STD
232	43	RCL	283	39	39
233	32	32	284	29	CP
234	22	INV	285	77	GE
235	44	SUM	286	02	02
236	22	22	287	91	91
237	43	RCL	288	00	0
238	22	22	289	42	STD
239	32	X:T	290	39	39
240	43	RCL	291	43	RCL
241	13	13	292	20	20
242	22	INV	293	55	+
243	77	GE	294	43	RCL
244	01	01	295	05	05
245	76	76	296	85	+
246	42	STD	297	43	RCL
247	22	22	298	21	21
248	61	GTD	299	55	+
249	01	01	300	43	RCL
250	76	76	301	06	06

Table 3. Continued

302	85	+			
303	43	RCL			
304	22	22			
305	55	-			
306	43	RCL			
307	07	07			
308	95	=			
309	65	X			
310	43	RCL			
311	15	15			
312	95	=			
313	42	STD			
314	34	34			
315	75	-			
316	43	RCL			
317	19	19			
318	95	=			
319	55	-			
320	43	RCL			
321	01	01			
322	95	=			
323	32	XIT			
324	04	4			
325	69	DP			
326	17	17			
327	43	RCL			
328	18	18			
329	77	GE			
330	03	03			
331	33	33			
332	32	XIT			
333	42	STD			
334	36	36			
335	65	X			
336	43	RCL			
337	04	04			
338	85	+			
339	43	RCL			
340	34	34			
341	95	=			
342	55	+			
343	43	RCL			
344	33	33			
345	95	=			
346	42	STD			
347	34	34			
348	87	IFF			
349	05	05			
350	03	03			
351	69	69			
352	43	RCL			
353	20	20			
354	99	PRT			
355	43	RCL			
356	21	21			
357	99	PRT			
358	43	RCL			
359	22	22			
360	99	PRT			
361	58	FIX			
362	02	02			
363	43	RCL			
364	36	36			
365	99	PRT			
366	43	RCL			
367	34	34			
368	99	PRT			
369	65	X			
370	43	RCL			
371	28	28			
372	55	+			
373	43	RCL			
374	14	14			
375	55	+			
376	43	RCL			
377	00	00			
378	95	=			
379	87	IFF			
380	05	05			
381	03	03			
382	84	84			
383	99	PRT			
384	65	X			
385	43	RCL			
386	29	29			
387	65	X			
388	43	RCL			
389	17	17			
390	95	=			
391	49	PRD			
392	33	33			
393	03	3			
394	00	0			
395	00	0			
396	65	X			
397	43	RCL			
398	16	16			
399	95	=			
400	42	STD			
401	34	34			

Table 3. Continued

402	43	RCL	453	42	STD
403	33	33	454	37	37
404	87	IFF	455	61	GTD
405	05	05	456	05	05
406	04	04	457	11	11
407	09	09	458	71	SBR
408	99	PRT	459	69	DP
409	00	0	460	42	STD
410	42	STD	461	37	37
411	36	36	462	61	GTD
412	42	STD	463	05	05
413	37	37	464	11	11
414	42	STD	465	43	RCL
415	38	38	466	26	26
416	71	SBR	467	71	SBR
417	69	DP	468	55	-
418	29	CP	469	77	GE
419	67	EQ	470	04	04
420	05	05	471	88	88
421	11	11	472	94	+/-
422	71	SBR	473	42	STD
423	00	00	474	36	36
424	24	24	475	43	RCL
425	77	GE	476	34	34
426	04	04	477	71	SBR
427	35	35	478	55	-
428	71	SBR	479	42	STD
429	69	DP	480	37	37
430	42	STD	481	71	SBR
431	36	36	482	89	π
432	61	GTD	483	42	STD
433	05	05	484	38	38
434	11	11	485	61	GTD
435	71	SBR	486	05	05
436	89	π	487	11	11
437	77	GE	488	43	RCL
438	04	04	489	26	26
439	65	65	490	75	-
440	43	RCL	491	43	RCL
441	26	26	492	34	34
442	71	SBR	493	95	=
443	55	-	494	77	GE
444	77	GE	495	05	05
445	04	04	496	07	07
446	58	58	497	94	+/-
447	94	+/-	498	42	STD
448	42	STD	499	37	37
449	36	36	500	71	SBR
450	71	SBR	501	89	π
451	00	00	502	42	STD
452	24	24	503	38	38

Table 3. Continued

504	61	GTD	554	65	*
505	05	05	555	93	.
506	11	11	556	00	0
507	71	SBR	557	00	0
508	69	DP	558	06	6
509	42	STD	559	05	5
510	38	38	560	06	6
511	93	.	561	65	*
512	00	0	562	43	RCL
513	03	3	563	29	29
514	04	4	564	95	=
515	03	3	565	42	STD
516	85	+	566	34	34
517	43	RCL	567	87	IFF
518	27	27	568	05	05
519	95	=	569	06	06
520	65	*	570	07	07
521	43	RCL	571	55	+
522	36	36	572	43	RCL
523	85	+	573	17	17
524	53	(	574	55	+
525	93	.	575	43	RCL
526	00	0	576	39	39
527	02	2	577	55	+
528	06	6	578	43	RCL
529	09	9	579	29	29
530	85	+	580	95	=
531	43	RCL	581	99	PRT
532	27	27	582	43	RCL
533	54	)	583	34	34
534	65	*	584	99	PRT
535	43	RCL	585	85	+
536	37	37	586	43	RCL
537	85	+	587	33	33
538	53	(	588	95	=
539	93	.	589	99	PRT
540	00	0	590	71	SBR
541	02	2	591	06	06
542	01	1	592	11	11
543	01	1	593	99	PRT
544	85	+	594	42	STD
545	43	RCL	595	35	35
546	27	27	596	98	ADV
547	54	)	597	00	0
548	65	*	598	42	STD
549	43	RCL	599	33	33
550	38	38	600	22	INV
551	85	+	601	58	FIX
552	43	RCL	602	86	STF
553	16	16	603	05	05



Table 3. Continued

604	61	GTD
605	01	01
606	46	46
607	44	SUM
608	33	33
609	43	RCL
610	33	33
611	55	+
612	43	RCL
613	25	25
614	55	+
615	43	RCL
616	29	29
617	55	+
618	43	RCL
619	17	17
620	95	=
621	42	STD
622	33	33
623	92	RTN

Table 4. System Information (Refer to Nomenclature List for Designations)

Designations	Value	Data Registers	Units
$H_V$	150,000	00	Btu/gal
$H_S - H_E$	435	01	Btu/lb
$H_S - H_H$	100	02	Btu/lb
$H_S - H_L$	205	03	Btu/lb
$H_E - H_C$	860	04	Btu/lb
$E_{3T}$	0.70	05	%
$E_{4T}$	0.68	06	%
$E_{5T}$	0.72	07	%
$M_{3M}$	2,000	08	lb/hr
$M_{4M}$	2,300	09	lb/hr
$M_{5M}$	5,000	10	lb/hr
$W_{3M}$	1,500	11	kW
$W_{4M}$	2,000	12	kW
$W_{5M}$	1,500	13	kW
$E_B$	0.72	14	%
	3,413	15	conversion factor
$D_U$	12,654	16	kW
	0.01	17	factor

Table 5. User Instructions

Step	Procedure	Enter	Press	Display
1	Turn on the TI-59 calculator and printer			0
2	Insert magnetic card/sides after pressing:		CLR	1.,2.,3.,4.
3	Enter $W_3$	$W_3$	A	$\Delta W_3$
4	Enter $W_4$	$W_4$	B	$\Delta W_4$
5	Enter $W_5$	$W_5$	C	$\Delta W_5$
6	Enter $M_H$	$M_H$	D	$M_H$
7	Enter $M_L$	$M_L$	E	$M_L$
8	Enter D	D	2nd A	D
9	Enter $K_1$	$K_1$	2nd B	$K_1$
10	Enter FA	FA	2nd C	FA
11	Enter PF	PF	2nd D	PF
12	Enter T	T	2nd E	T
13	Start to run the program		RST	"C"

Table 6. Sample Input/Output Printout

<u>Parameters</u>	<u>Input</u>
W <sub>3</sub> (A)	3,500
W <sub>4</sub> (B)	4,000
W <sub>5</sub> (C)	5,000
M <sub>H</sub> (D)	81,300
M <sub>L</sub> (E)	21,600
D (A')	16,500
K <sub>1</sub> (B')	100,000
F <sub>A</sub> (C')	0.0024
P <sub>F</sub> (D')	58
T (E')	8
	<u>First Output</u>
W <sub>3</sub>	3,500
W <sub>4</sub>	4,000
W <sub>5</sub>	5,000
M <sub>C</sub>	110,999.68
T <sub>HR</sub>	12,504.21
C <sub>US</sub>	6.72
C <sub>TS</sub>	6,715.22
C <sub>UP</sub>	5.01
C <sub>TP</sub>	1,601.68
C <sub>T</sub>	8,316.90
C <sub>U</sub>	6.30
	<u>Final Output</u>
W <sub>3</sub>	2,100
W <sub>4</sub>	2,400
W <sub>5</sub>	3,000
M <sub>C</sub>	55,052.22
T <sub>HR</sub>	11,180.08

continued

Table 6. Continued

<u>Parameters</u>	<u>Final Output</u>
$C_{US}$	6.00
$C_{TS}$	3,602.47
$C_{UP}$	3.85
$C_{TP}$	2,773.68
$C_T$	6,376.15
$C_U$	4.83

Table 7. Utility Rate Structures and Fuel Prices Used in Figure 6

	Curve #1	Curve #2	Curve #3	Curve #4
	1972	March 1976		Aug 1979
		Before	After	
Demand charge, \$/kW (with discount)	1.65	2.475	4.15	4.72
Energy charge, ¢/kW-hr (subject to 5% discount)				
1st 50,000	1.3	1.95	3.19	3.43
over 50,000 and up to 300 x demand	1.02	1.53	2.50	2.69
over 300 x demand	0.8	1.2	1.96	2.11
fuel price, ¢/gal	10	32	32	58

Date	Input to Computer			Optimum Operation Per Computer				Actual Operation			
	kw Total Demand	200 psi PPH Steam Demand	Fuel Price cents/gallon	kw Self-Generated	Total Self Gen. Cost	Total Utility Cost	Total Cost	200 psi PPH Steam Demand	kw Total Demand	Total Cost	
	kw Peak Demand	5 psi PPH Steam Demand	K <sub>1</sub> Energy Consumed	Heat Rate Btu/kw-hr	Unit Self Gen. Cost	Unit Utility Cost	Unit Cost	5 psi PPH Steam Demand	kw Self-Gen.	Unit Cost	

Table 8. User data sheet.

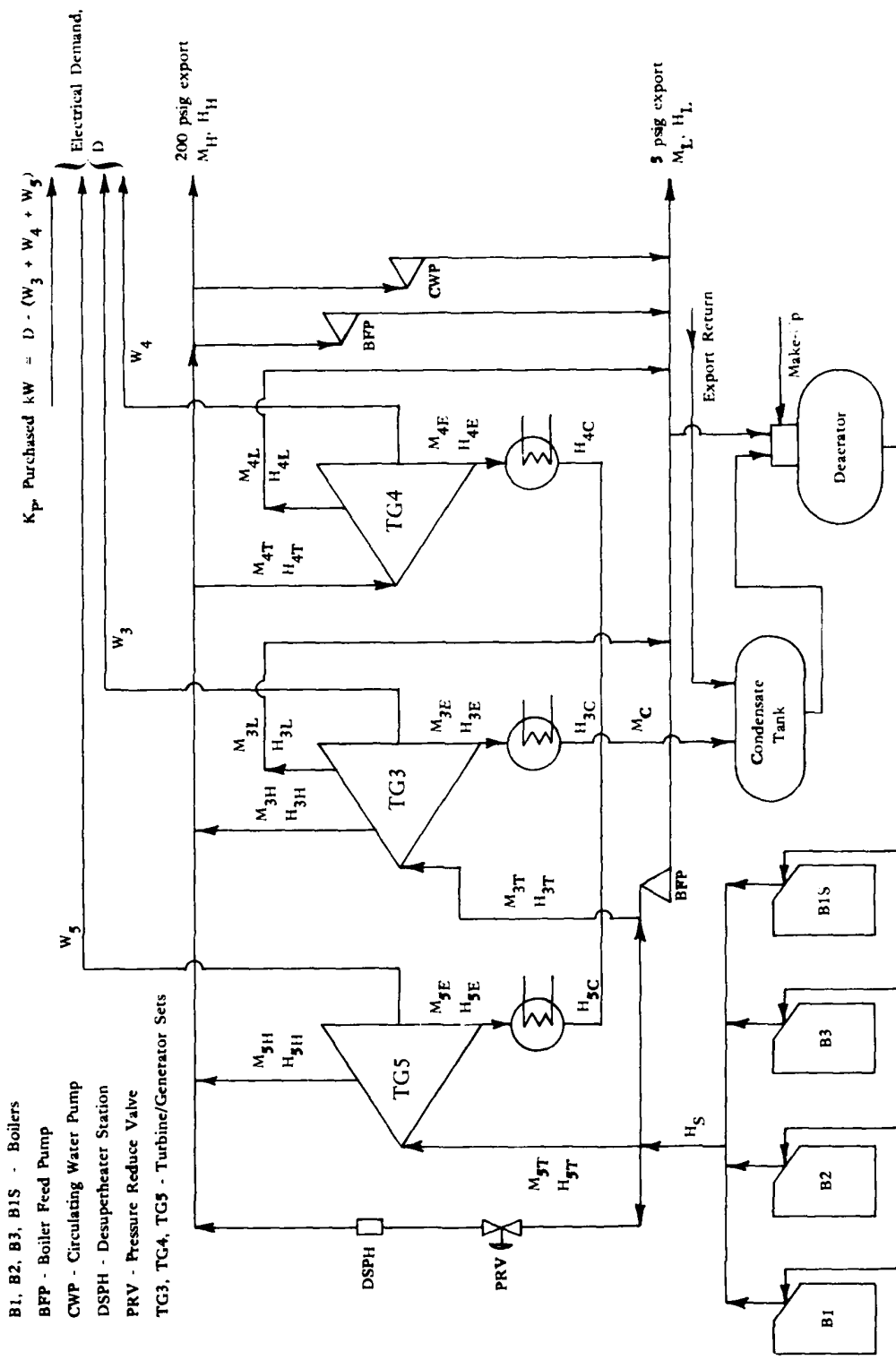

Figure 1. Flow sheet for cogeneration system at SUBASE, New London, Conn. (Refer to nomenclature list for symbols)



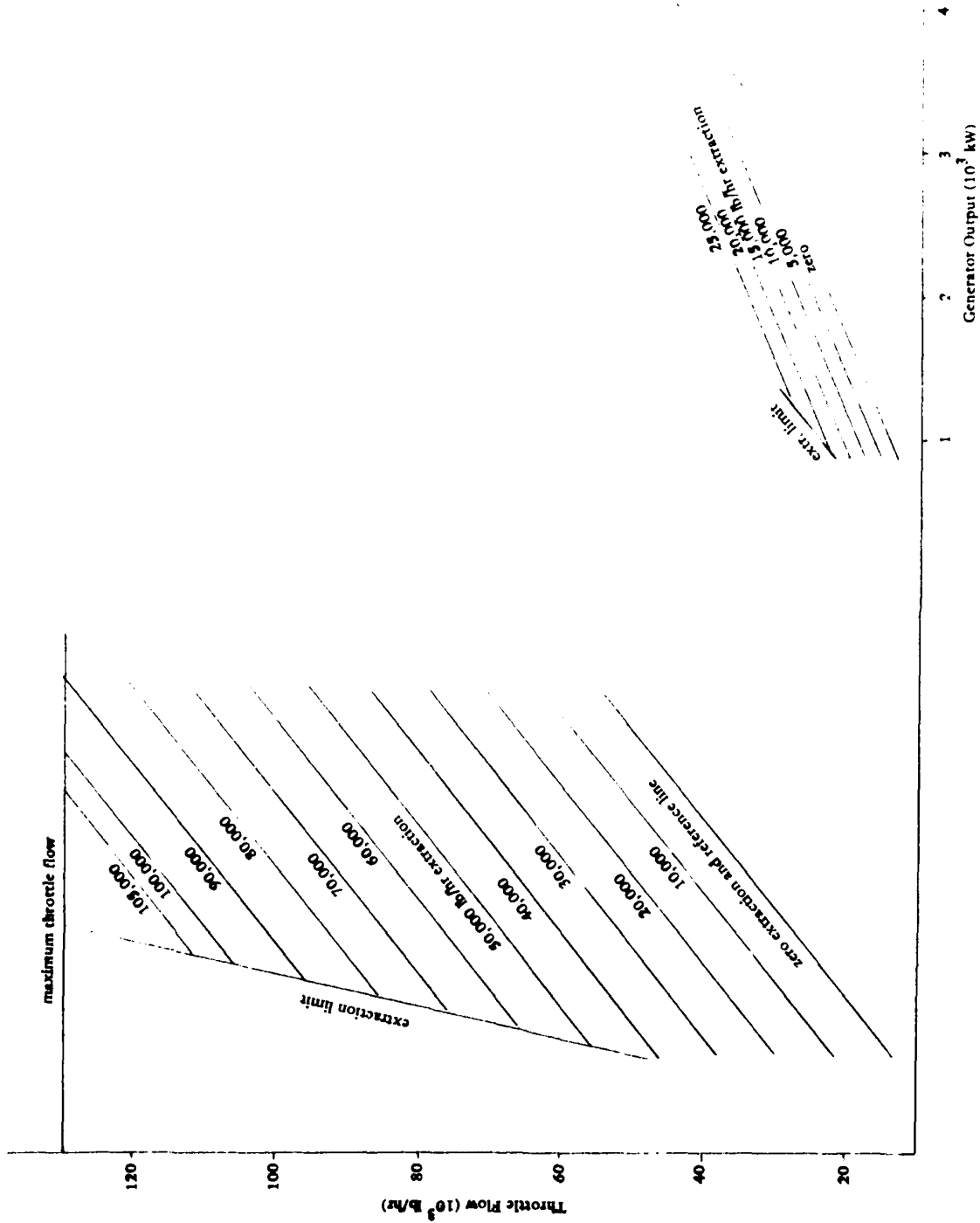

Figure 2. Turbine/generator No. 3 (TG3) performance.

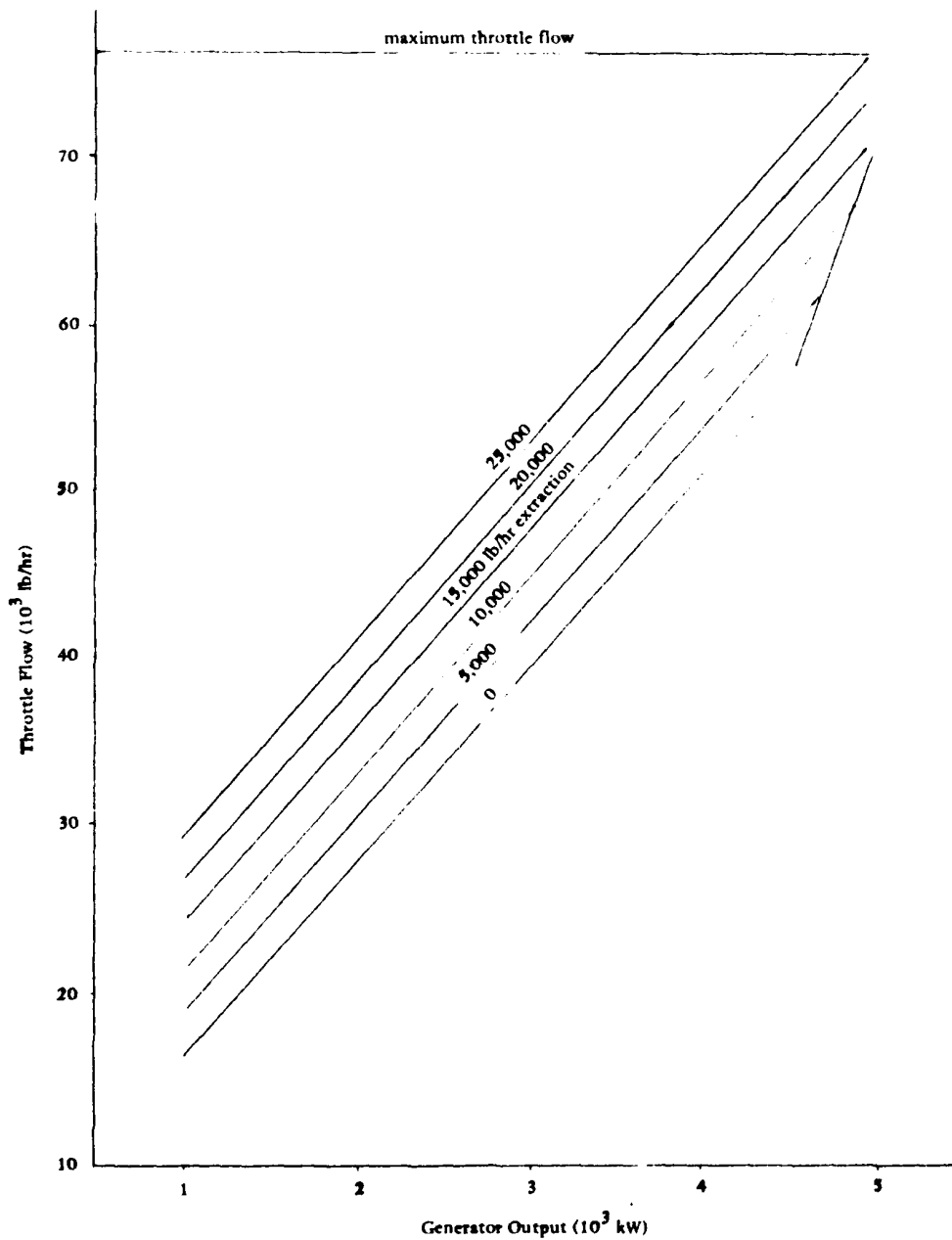

Figure 3. Turbine/generator No. 4 (TG4) performance.

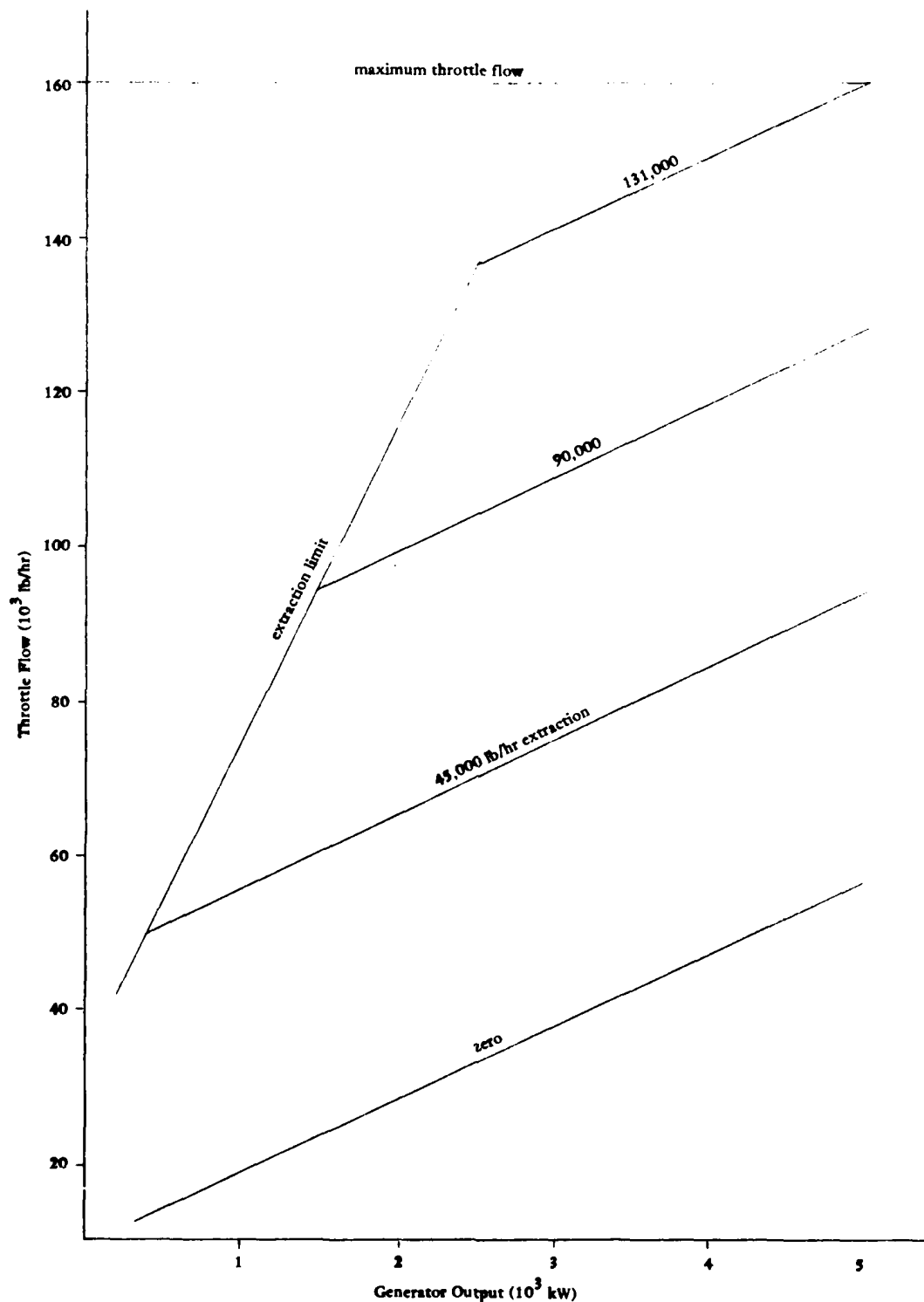

Figure 4. Turbine/generator No. 5 (TG5) performance.

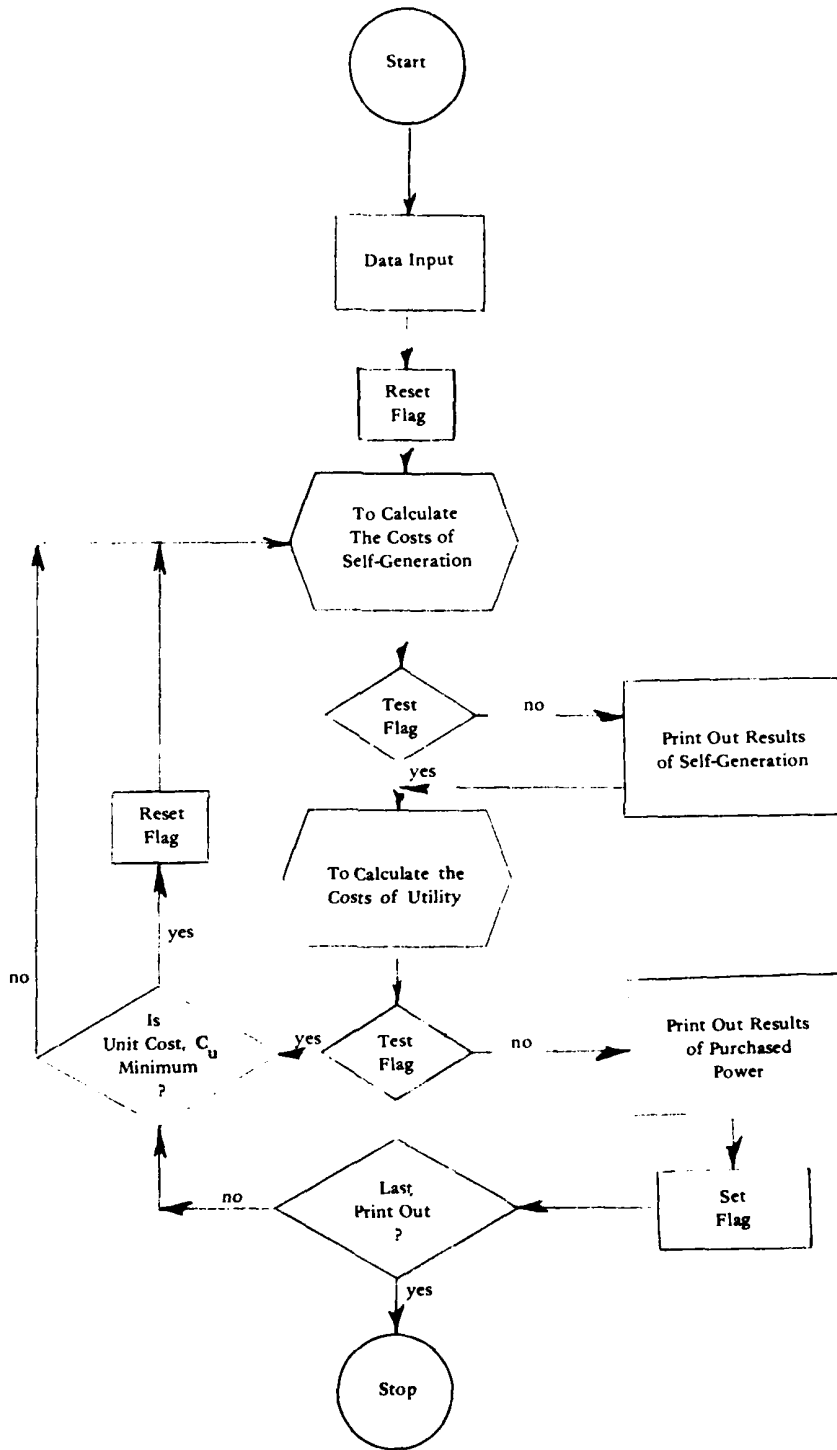

Figure 5. Flow chart of computer program.

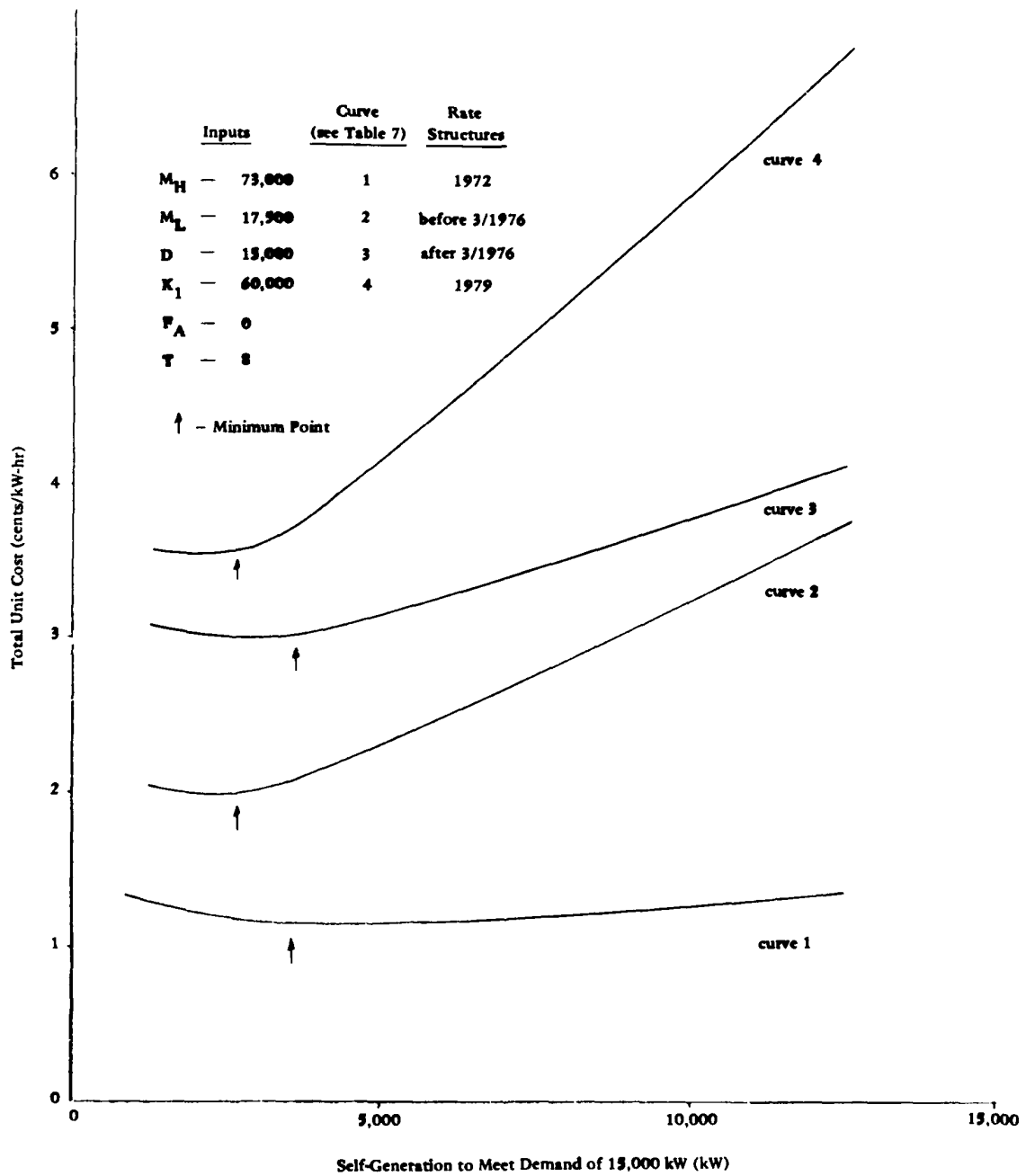

Figure 6. Effect of the rate structure and fuel price on total unit cost.  
(Refer to Table 7 for data)

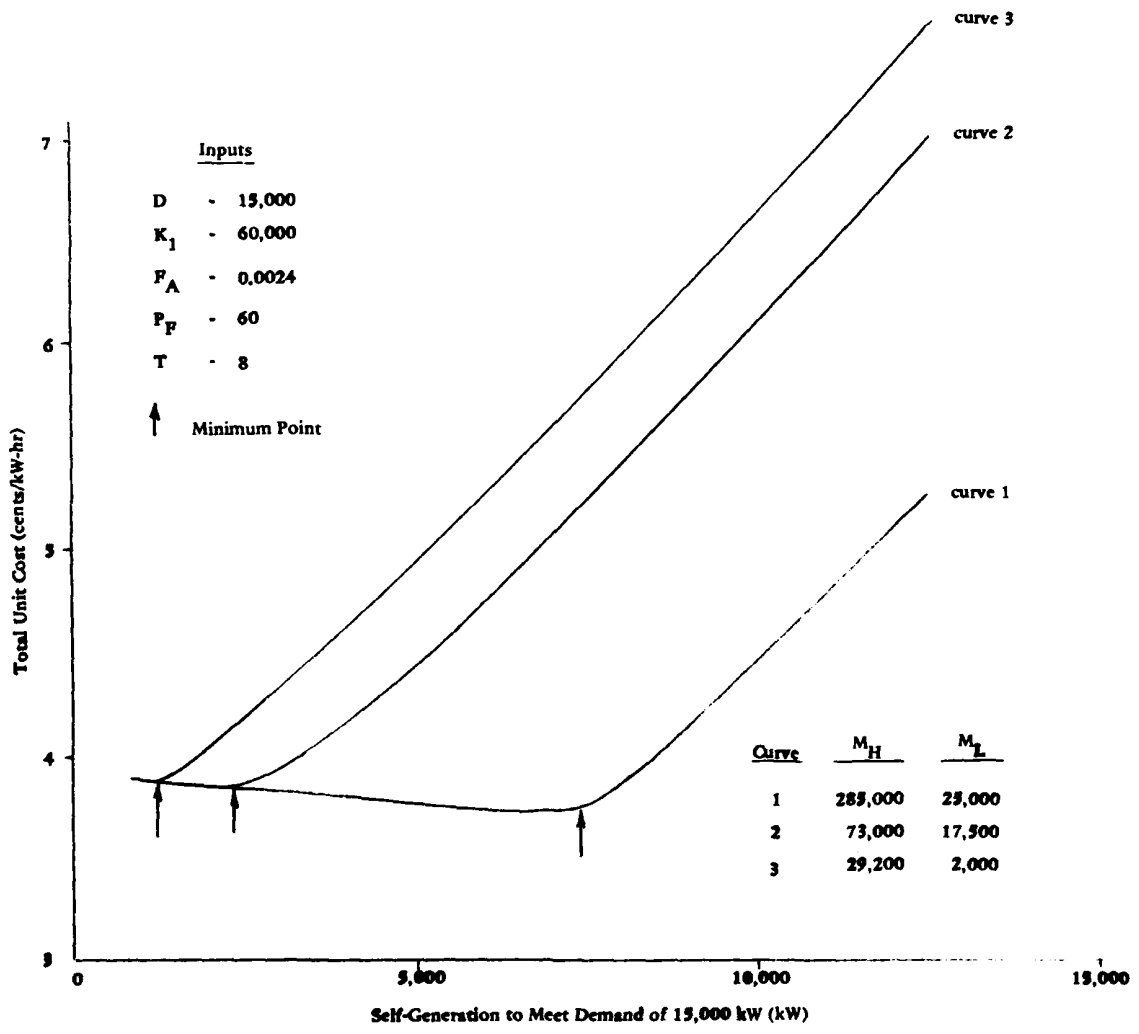

Figure 7. Effect of the steam load on total unit cost.

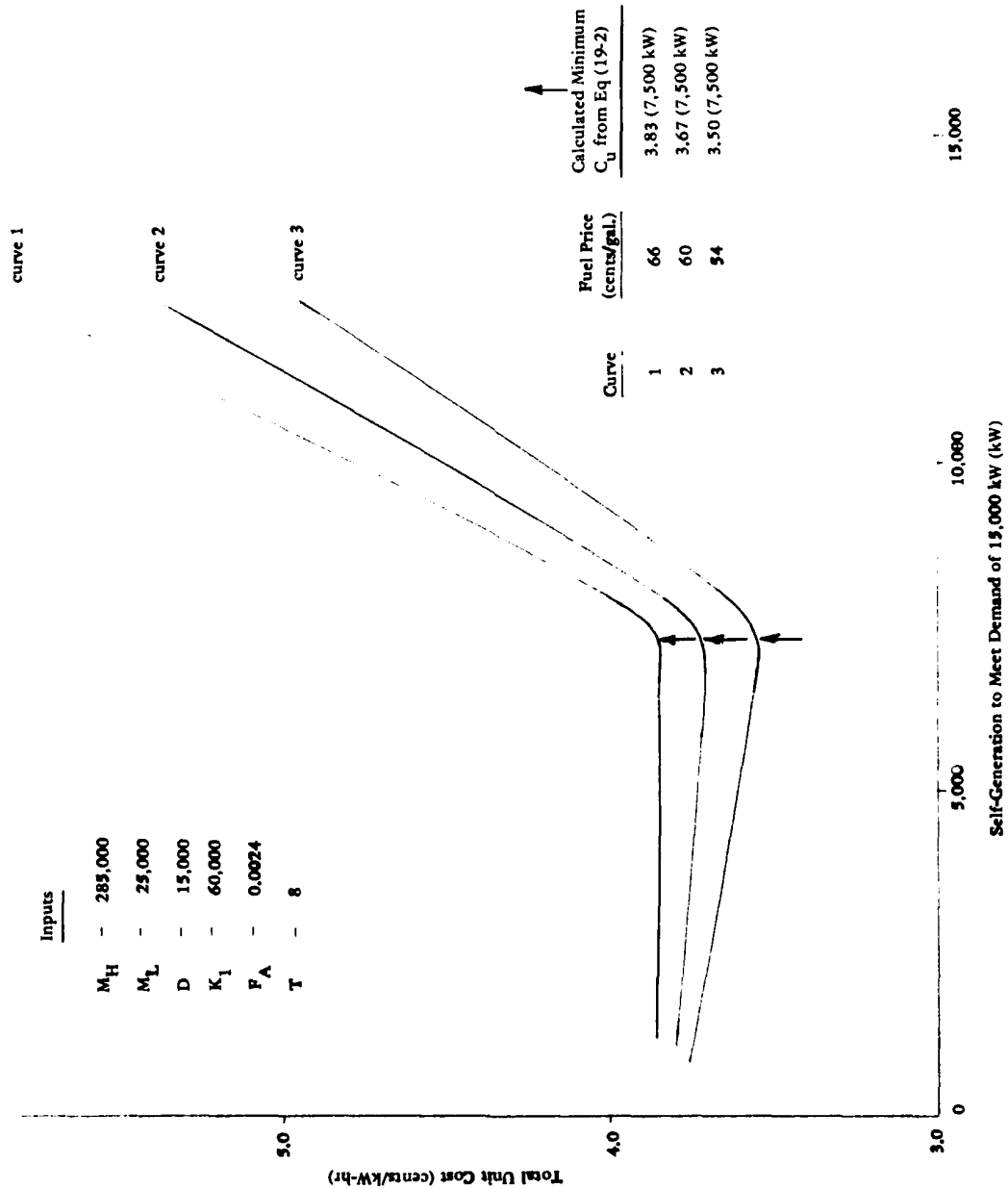

Figure 8. Effect of the fuel price on total unit cost.

## NOMENCLATURE LIST

$C_T$	Total cost (\$)	$H_V$	Heating value of fuel (Btu/gal)
$C_{TP}$	Total cost (\$) of purchased power	$K_P$	Purchased electrical power (kW)
$C_{TS}$	Total cost (\$) of self-generated power	$K_1$	Cumulative purchased energy (kW-hr) at the beginning of each run
$C_U$	Unit cost (¢/kW-hr)	$K_2$	Cumulative purchased energy (kW-hr) at the end of each run
$C_{UP}$	Unit cost (¢/kW-hr) of purchased power	$M_C$	Total condensing flow from turbine (lb/hr)
$C_{US}$	Unit cost (¢/kW-hr) of self-generated power	$M_H$	High-pressure (200-psig) export steam (lb/hr)
$D$	Electrical demand (kW)	$M_{iE}$	Flow rate (lb/hr) at turbine outlet of TG <sub>i</sub>
$D_U$	Utility peak demand (kW)	$M_{iH}$	Flow rate (lb/hr) at high-pressure (200-psig) extraction point of TG <sub>i</sub>
$E_B$	Boiler overall efficiency	$M_{iL}$	Flow rate (lb/hr) at low-pressure (5-psig) extraction point of TG <sub>i</sub>
$E_{iT}$	Overall efficiency of TG <sub>i</sub>	$M_{iM}$	Minimum required exhaust steam flow (lb/hr) of TG <sub>i</sub>
$F_A$	Fuel adjustment factor (\$/kW-hr)	$M_{iT}$	Flow rate (lb/hr) at turbine throttle of TG <sub>i</sub>
$H_C$	Enthalpy (Btu/lb) of the mixed condensate	$M_L$	Low-pressure (5-psig) export steam (lb/hr)
$H_E$	Enthalpy (Btu/lb) of the mixed exhaust steam	$P_F$	Fuel price (¢/gal)
$H_{iC}$	Enthalpy (Btu/lb) at condenser outlet of TG <sub>i</sub>	$T$	Time period of interest (hr) for each run which may be a period of one shift or less
$H_{iE}$	Enthalpy (Btu/lb) at turbine outlet of TG <sub>i</sub>	$T_{HR}$	Heat rate of turbine/generator sets
$H_H$	Enthalpy (Btu/lb) of high-pressure (200-psig) export steam	$W_i$	Electrical output (kW) of TG <sub>i</sub>
$H_{iH}$	Enthalpy (Btu/lb) at high-pressure (200-psig) extraction point of TG <sub>i</sub>	$W_{iM}$	Low limit of electrical output (kW) of TG <sub>i</sub>
$H_L$	Enthalpy (Btu/lb) of low-pressure (5-psig) export steam	$W_T$	Total self-generated electricity (kW)
$H_{iL}$	Enthalpy (Btu/lb) at low-pressure (5-psig) extraction point of TG <sub>i</sub>		
$H_S$	Enthalpy (Btu/lb) of steam from boilers		
$H_{iT}$	Enthalpy (Btu/lb) at turbine throttle of TG <sub>i</sub>		



## DISTRIBUTION LIST

AAP NAVORDSTA IND HD DET PW ENGRNG DIV. McAlester, OK  
AFB (AFIT/LD), Wright-Patterson OH; ABG/DEE (F. Nethers), Goodfellow AFB TX; AF Tech Office (Mgt & Ops), Tyndall, FL; AFCEC/XR, Tyndall FL; CESCH, Wright-Patterson; MAC DET (Col. P. Thompson) Scott, IL; SAMSO/MNND, Norton AFB CA; Samsco, Vandenburg, AFB, CA; Stinfo Library, Offutt NE  
ARMY BMDSC-RE (H. McClellan) Huntsville AL; DAEN-CWE-M (LT C D Binning), Washington DC;  
DAEN-MPE-D Washington DC; DAEN-MPU, Washington DC; ERADCOM Tech Supp Dir. (DELSD-I) Ft. Monmouth, NJ; Natick Cen (Kwoh Hu) Natick MA; Tech. Ref. Div., Fort Huachuca, AZ  
ARMY - CERL Library, Champaign IL  
ARMY CORPS OF ENGINEERS MRD-Eng. Div., Omaha NE; Seattle Dist. Library, Seattle WA  
ARMY CRREL G. Phetteplace Hanover, NH  
ARMY DARCOM AMCPM-CS (J. Carr), Alexandria VA  
ARMY ENGR DIST. Library, Portland OR  
ARMY ENVIRON. HYGIENE AGCY Water Qual Div (Doner), Aberdeen Prov Ground, MD  
ARMY MATERIALS & MECHANICS RESEARCH CENTER Dr. Lenoce, Watertown MA  
ARMY MISSILE R&D CMD Redstone Arsenal AL Sci. Info. Cen (Documents)  
ASO PWD (ENS J.A. Jenkins), Philadelphia, PA  
ASST SECRETARY OF THE NAVY Spec. Assist Energy (Leonard), Washington, DC  
BUREAU OF RECLAMATION Code 1512 (C. Selander) Denver CO  
CINCLANT Civil Engr. Supp. Plans. Ofr Norfolk, VA  
CNAVRES Code 13 (Dir. Facilities) New Orleans, LA  
CNM Code MAT-08T3, Washington, DC  
CNO Code NOP-964, Washington DC; Code OP 987 Washington DC; Code OP-413 Wash, DC; Code OPNAV 09B24 (H); OP987J (J. Boosman), Pentagon  
COMFLEACT, OKINAWA PWO, Kadena, Okinawa  
COMNAVMARIANAS Code N4, Guam  
COMOCEANSYSPAC SCE, Pearl Harbor HI  
COMSUBDEVRUONE Operations Ofr, San Diego, CA  
DOE F.F. Parry, Washington DC; INEL Tech. Lib. (Reports Section), Idaho Falls, ID; Liffick, Richmond, WA; P. Jordan Washington, DC  
DTIC Defense Technical Info Ctr Alexandria, VA  
DTNSRDC Code 4111 (R. Gierich), Bethesda MD  
DTNSRDC Code 522 (Library), Annapolis MD  
ENVIRONMENTAL PROTECTION AGENCY Reg. VIII, 8M-ASL, Denver CO  
FLTCOMBATTRACENLANT PWO, Virginia Bch VA  
GSA Office of Const. Mgmt (M. Whitley), Washington DC  
KWAJALEIN MISRAN BMDSC-RKL-C  
LIBRARY OF CONGRESS Washington, DC (Sciences & Tech Div)  
MARINE CORPS BASE Camp Pendleton CA 92055; Code 43-260, Camp Lejeune NC; PWO Camp Lejeune NC; PWO, Camp S. D. Butler, Kawasaki Japan  
MARINE CORPS HQS Code LFF-2, Washington DC  
MCAS Facil. Engr. Div. Cherry Point NC; CO, Kaneohe Bay HI; Code S4, Quantico VA; PWO Kaneohe Bay HI; PWO, Yuma AZ; SCE, Futema Japan  
MCDEC NSAP REP, Quantico VA  
MCLSBPAC B520, Barstow CA; PWO, Barstow CA  
MCRD PWO, San Diego Ca  
NAF PWD - Engr Div, Atsugi, Japan; PWO Sigonella Sicily; PWO, Atsugi Japan  
NALF OINC, San Diego, CA  
NARF Code 100, Cherry Point, NC; Code 612, Jax, FL; Code 640, Pensacola FL  
NAS CO, Guantanamo Bay Cuba; Code 114, Alameda CA; Code 183 (Fac. Plan BR MGR); Code 18700, Brunswick ME; Code 18U (ENS P.J. Hickey), Corpus Christi TX; Code 8E, Patuxent Riv., MD; Dir. Util. Div., Bermuda; ENS Buchholz, Pensacola, FL; Lakehurst, NJ; Lead. Chief, Petty Ofr. PW/Self Help Div., Beeville TX; PW (J. Maguire), Corpus Christi TX; PWD Maint. Cont. Dir., Fallon NV; PWD Maint. Div., New Orleans, Belle Chasse LA; PWD, Maintenance Control Dir., Bermuda; PWO Belle Chasse, LA; PWO Chase Field Beeville, TX; PWO Key West FL; PWO Whiting Fld, Milton FL; PWO, Dallas TX; PWO,

Glenview IL; PWO, Millington TN; PWO, Miramar, San Diego CA; SCE Lant Fleet Norfolk, VA; SCE Norfolk, VA; SCE, Barbers Point HI; Security Offr, Alameda CA  
 NATL RESEARCH COUNCIL Naval Studies Board, Washington DC  
 NAVAEROSPREGMEDCEN SCE, Pensacola FL  
 NAVCOASTSYSTCTR CO, Panama City FL; Code 713 (J. Quirk) Panama City, FL; Library Panama City, FL  
 NAVCOMMAREAMSTRSTA PWO, Norfolk VA; PWO, Wahiawa HI; SCE Unit 1 Naples Italy  
 NAVCOMMSTA CO (61E) Puerto Rico; Code 401 Nea Makri, Greece; PWO, Exmouth, Australia; PWO, Fort Amador Canal Zone  
 NAVEDTRAPRODEVEN Tech. Library  
 NAVEDUTRACEN Engr Dept (Code 42) Newport, RI  
 NAVFAC PWO, Cape Hatteras, Buxton NC; PWO, Centerville Beh, Ferndale CA; PWO, Guam  
 NAVFAC PWO, Lewes DE  
 NAVFACENGCOM Code 043 Alexandria, VA; Code 044 Alexandria, VA; Code 0451 Alexandria, VA; Code 0454B Alexandria, VA; Code 081B Alexandria, VA; Code 100 Alexandria, VA; Code 1023 (T. D. Stevens), Alexandria VA; Code 1113 (M. Carr) Alexandria, VA; Code 1113 (T. Stevens) Alexandria, VA; Morrison Yap, Caroline Is.  
 NAVFACENGCOM - CHES DIV. Code 102, (Wildman), Wash, DC; Code 403 (H. DeVoe) Wash, DC; Code FPO-1 Wash, DC  
 NAVFACENGCOM - LANT DIV. CDR E. Peltier; Code 111, Norfolk, VA; Eur. BR Deputy Dir, Naples Italy; European Branch, New York; RDT&ELO 102, Norfolk VA  
 NAVFACENGCOM - NORTH DIV. Code 09P (LCDR A.J. Stewart); Code 1028, RDT&ELO, Philadelphia PA; Code 111 (Castranovo) Philadelphia, PA; Design Div. (R. Masino), Philadelphia PA; ROICC, Contracts, Crane IN  
 NAVFACENGCOM - PAC DIV. (Kyi) Code 101, Pearl Harbor, HI; Code 402, RDT&E, Pearl Harbor HI; Commander, Pearl Harbor, HI  
 NAVFACENGCOM - SOUTH DIV. Code 90, RDT&ELO, Charleston SC  
 NAVFACENGCOM - WEST DIV. 112; AROICC, Contracts, Twentynine Palms CA; Code 04B San Bruno, CA; O9P20 San Bruno, CA; RDT&ELO Code 2011 San Bruno, CA  
 NAVFACENGCOM CONTRACT AROICC, Quantico, VA; Dir. Eng. Div., Exmouth, Australia; Eng Div dir, Southwest Pac, Manila, PI; OICC (Knowlton), Kaneohe, HI; OICC, Southwest Pac, Manila, PI; OICC/ROICC, Balboa Canal Zone; ROICC AF Guam; ROICC, Keflavik, Iceland; ROICC, Pacific, San Bruno CA  
 NAVNUPWRU MUSE DET Code NPU-30 Port Hueneme, CA  
 NAVOCEANSYSCEN Code 523 (Hurley), San Diego, CA; Code 6700, San Diego, CA; Code 811 San Diego, CA; Research Lib., San Diego CA; Tech. Library, Code 447  
 NAVORDSTA PWO, Louisville KY  
 NAVPETOFF Code 30, Alexandria VA  
 NAVPETRES Director, Washington DC  
 NAVPHIBASE CO, ACB 2 Norfolk, VA; Code S3T, Norfolk VA  
 NAVREGMEDCEN SCE San Diego, CA; SCE, Camp Pendleton CA; SCE, Guam; SCE, Oakland CA  
 NAVSCOLCECOFF C35 Port Hueneme, CA  
 NAVSEASYSYSCOM Code 0325, Program Mgr, Washington, DC; Code OOC (LT R. MacDougal), Washington DC; Code SEA OOC Washington, DC  
 NAVSEC Code 6034 (Library), Washington DC  
 NAVSECGRUACT PWO, Adak AK; PWO, Edzell Scotland; PWO, Puerto Rico; PWO, Torri Sta, Okinawa  
 NAVSHIPYD Code 202.4, Long Beach CA; Code 202.5 (Library) Puget Sound, Bremerton WA; Code 380, (Woodroff) Norfolk, Portsmouth, VA; Code 400, Puget Sound; Code 400.03 Long Beach, CA; Code 404 (LT J. Riccio), Norfolk, Portsmouth VA; Code 410, Mare Is., Vallejo CA; Code 440 Portsmouth NH; Code 440, Norfolk; Code 440, Puget Sound, Bremerton WA; Code 450, Charleston SC; Code 453 (Util. Supr), Vallejo CA; Library, Portsmouth NH; PWO, Mare Is.; PWO, Puget Sound; SCE, Pearl Harbor HI  
 NAVSTA AROICC, Brooklyn NY; CO Naval Station, Mayport FL; CO, Brooklyn NY; Code 4, 12 Marine Corps Dist, Treasure Is., San Francisco CA; Dir Mech Engr, Gtmo; Engr. Dir., Rota Spain; Long Beach, CA; Maint. Cont. Div., Guantanamo Bay Cuba; Maint. Div. Dir Code 531, Rodman Canal Zone; PWO Midway Island; PWO, Keflavik Iceland; PWO, Mayport FL; ROICC, Rota Spain; SCE, Guam, SCE, San Diego CA; SCE, Subic Bay, R.P.; Utilities Engr Off. (A.S. Ritchie), Rota Spain  
 NAVSUBASE ENS S. Dove, Groton, CT  
 NAVSUPPACT CO, Seattle WA; Code 413, Seattle WA; LTJG McGarran, SEC, Vallejo, CA  
 NAVSURFWPCEN PWO, White Oak, Silver Spring, MD

NAVTECHTRACEN SCE. Pensacola FL  
 NAVUSEAWARENGSTA Keyport, WA  
 NAVWPNCEN Code 2636 (W. Bonner), China Lake CA; PWO (Code 26), China Lake CA; ROICC (Code 702), China Lake CA  
 NAVWPNEVALFAC Technical Library, Albuquerque NM  
 NAVWPNSTA Code 092A (C. Fredericks) Seal Beach CA  
 NAVWPNSTA PW Office (Code 09C1) Yorktown, VA  
 NAVWPNSTA PWO, Seal Beach CA  
 NAVWPNSUPPCEN Code 09 Crane IN  
 NCBU 405 OIC, San Diego, CA  
 NCBC Code 10 Davisville, RI; Code 155, Port Hueneme CA; Code 156, Port Hueneme, CA; Code 25111 Port Hueneme, CA; NESO Code 251 P.R. Winter Port Hueneme, CA; PW Engrg. Gulfport MS; PWO (Code 80) Port Hueneme, CA; PWO, Davisville RI  
 NMCB 5, Operations Dept.: THREE, Operations Off.  
 NOAA Library Rockville, MD  
 NRL Code 8400 Washington, DC  
 NSC Code 54.1 (Wynne), Norfolk VA  
 NSD SCE, Subic Bay, R.P.  
 NTC Commander Orlando, FL  
 NUSC Code 131 New London, CT; Code EA123 (R.S. Munn), New London CT; Code SB 331 (Brown), Newport RI  
 OCEANSYSLANT LT A R. Giancola, Norfolk VA  
 OFFICE SECRETARY OF DEFENSE OASD (MRA&L) Pentagon (T. Casberg), Washington, DC  
 ONR Code 221, Arlington VA; Code 700F Arlington VA; Dr. A. Laufer, Pasadena CA  
 PHIBCB 1 P&E, Coronado, CA  
 PMTC Code 3331 (S. Opatowsky) Point Mugu, CA; Pat. Counsel, Point Mugu CA  
 PWC ACE Office (LTJG St. Germain) Norfolk VA; CO Norfolk, VA; CO, (Code 10), Oakland, CA; CO, Great Lakes IL; Code 10, Great Lakes, IL; Code 110, Oakland, CA; Code 120, Oakland CA; Code 120C, (Library) San Diego, CA; Code 154, Great Lakes, IL; Code 200, Great Lakes IL; Code 220 Oakland, CA; Code 220.1, Norfolk VA; Code 30C, San Diego, CA; Code 400, Great Lakes, IL; Code 400, Oakland, CA; Code 400, Pearl Harbor, HI; Code 400, San Diego, CA; Code 420, Great Lakes, IL; Code 420, Oakland, CA; Code 42B (R. Pasqua), Pearl Harbor HI; Code 505A (H. Wheeler); Code 600, Great Lakes, IL; Code 601, Oakland, CA; Code 610, San Diego CA; Code 700, Great Lakes, IL; LTJG J.L. McClaine, Yokosuka, Japan; Utilities Officer, Guam; XO (Code 20) Oakland, CA  
 TVA Smelser, Knoxville, Tenn.  
 U.S. MERCHANT MARINE ACADEMY Kings Point, NY (Reprint Custodian)  
 US GEOLOGICAL SURVEY Off. Marine Geology, Piteleki, Reston VA  
 USAF Jack S. Spencer, Washington, DC  
 USAF REGIONAL HOSPITAL Fairchild AFB, WA  
 USCG (G-ECV) Washington Dc; (Smith), Washington, DC  
 USCG R&D CENTER Tech. Dir. Groton, CT  
 USNA Ch. Mech. Engr. Dept Annapolis MD; Energy-Environ Study Grp, Annapolis, MD; Engr. Div. (C. Wu) Annapolis MD; Environ. Prot. R&D Prog. (J. Williams), Annapolis MD; Ocean Sys. Eng Dept (Dr. Monney) Annapolis, MD; PWD Engr. Div. (C. Bradford) Annapolis MD  
 ARIZONA State Energy Programs Off., Phoenix AZ  
 BONNEVILLE POWER ADMIN Portland OR (Energy Consvr. Off., D. Davey)  
 BROOKHAVEN NATL LAB M. Steinberg, Upton NY  
 CALIFORNIA STATE UNIVERSITY LONG BEACH, CA (CHELAPATI)  
 CORNELL UNIVERSITY Ithaca NY (Serials Dept, Engr Lib.)  
 DAMES & MOORE LIBRARY LOS ANGELES, CA  
 FLORIDA ATLANTIC UNIVERSITY Boca Raton, FL (McAllister)  
 FLORIDA TECHNOLOGICAL UNIVERSITY ORLANDO, FL (HARTMAN)  
 FOREST INST. FOR OCEAN & MOUNTAIN Carson City NV (Studies - Library)  
 FUEL & ENERGY OFFICE CHARLESTON, WV  
 GEORGIA INSTITUTE OF TECHNOLOGY (LT R. Johnson) Atlanta, GA  
 HAWAII STATE DEPT OF PLAN. & ECON DEV. Honolulu HI (Tech Info Ctr)  
 INDIANA ENERGY OFFICE Energy Group, Indianapolis, IN  
 WOODS HOLE OCEANOGRAPHIC INST. Woods Hole MA (Winget)

KEENE STATE COLLEGE Keene NH (Cunningham)  
 LEHIGH UNIVERSITY BETHLEHEM, PA (MARINE GEOCHEMICAL LAB., RICHARDS), Bethlehem  
 PA (Linderman Lib. No.30, Fleckstener)  
 MAINE OFFICE OF ENERGY RESOURCES Augusta, ME  
 MISSOURI ENERGY AGENCY Jefferson City MO  
 MIT Cambridge MA (Rm 10-500, Tech. Reports, Engr. Lib.), Cambridge, MA (Harleman)  
 MONTANA ENERGY OFFICE Anderson, Helena, MT  
 NAVAL ACADEMY OF ENG. ALEXANDRIA, VA (STARBUCK, JR.)  
 NEW HAMPSHIRE Concord, NH (Governor's Council On Energy)  
 NEW MEXICO SOLAR ENERGY INST. Dr. Zwiibel Las Cruces NM  
 NY CITY COMMUNITY COLLEGE BROOKLYN, NY (LIBRARY)  
 NYS ENERGY OFFICE Library, Albany NY  
 POLLUTION ABATEMENT ASSOC. Graham  
 PURDUE UNIVERSITY Lafayette, IN (CE Engr. Lib.)  
 CONNECTICUT Hartford CT (Dept of Plan. & Energy Policy)  
 SCRIPPS INSTITUTE OF OCEANOGRAPHY LA JOLLA, CA (ADAMS)  
 SEATTLE U. Prof. Schwaegler Seattle WA  
 STANFORD UNIVERSITY Engr. Lib., Stanford CA  
 STATE UNIV. OF NEW YORK Fort Schuyler, NY (Longobardi)  
 TEXAS A&M UNIVERSITY W.B. Ledbetter College Station, TX  
 UNIVERSITY OF CALIFORNIA Energy Engineer, Davis CA; LIVERMORE, CA (LAWRENCE  
 LIVERMORE LAB., TOKARZ)  
 UNIVERSITY OF DELAWARE Newark, DE (Dept of Civil Engineering, Chesson)  
 UNIVERSITY OF HAWAII HONOLULU, HI (SCIENCE AND TECH. DIV.)  
 UNIVERSITY OF ILLINOIS URBANA, IL (LIBRARY); URBANA, IL (NEWMARK)  
 UNIVERSITY OF MASSACHUSETTS (Heronemus), Amherst MA CE Dept  
 UNIVERSITY OF NEBRASKA-LINCOLN Lincoln, NE (Ross Ice Shelf Proj.)  
 UNIVERSITY OF TEXAS Inst. Marine Sci (Library), Port Arkansas TX  
 UNIVERSITY OF TEXAS AT AUSTIN AUSTIN, TX (THOMPSON)  
 UNIVERSITY OF WASHINGTON Seattle WA (E. Linger); Seattle, WA Transportation, Construction &  
 Geom. Div  
 UNIVERSITY OF WISCONSIN Milwaukee WI (Ctr of Great Lakes Studies)  
 VIRGINIA INST. OF MARINE SCI. Gloucester Point VA (Library)  
 ARVID GRANT OLYMPIA, WA  
 ATLANTIC RICHFIELD CO. DALLAS, TX (SMITH)  
 BAGGS ASSOC. Beaufort, SC  
 BECHTEL CORP. SAN FRANCISCO, CA (PHELPS)  
 BRITISH EMBASSY Sci. & Tech. Dept. (J. McAuley), Washington DC  
 BROWN & CALDWELL E M Saunders Walnut Creek, CA  
 BROWN & ROOT Houston TX (D. Ward)  
 CANADA Nova Scotia Rsch Found., Corp. Dartmouth, Nova Scotia; Trans-Mnt Oil Pipe Lone Corp.  
 Vancouver, BC Canada  
 CHEMED CORP Lake Zurich IL (Dearborn Chem. Div.Lib.)  
 COLUMBIA GULF TRANSMISSION CO. HOUSTON, TX (ENG. LIB.)  
 DESIGN SERVICES Beck, Ventura, CA  
 DIXIE DIVING CENTER Decatur, GA  
 DURLACH, O'NEAL, JENKINS & ASSOC. Columbia SC  
 FORD, BACON & DAVIS, INC. New York (Library)  
 MCDONNELL AIRCRAFT CO. Dept 501 (R.H. Fayman), St Louis MO  
 MEDERMOTT & CO. Diving Division, Harvey, LA  
 NEWPORT NEWS SHIPBLDG & DRYDOCK CO. Newport News VA (Tech. Lib.)  
 PACIFIC MARINE TECHNOLOGY Duvall, WA (Wagner)  
 PORTLAND CEMENT ASSOC. Skokie IL (Rsch & Dev Lab, Lib.)  
 RAYMOND INTERNATIONAL INC. E Colle Soil Tech Dept, Pennsauken, NJ  
 SANDIA LABORATORIES Albuquerque, NM (Vortman); Library Div., Livermore CA  
 SCHUPACK ASSOC SO. NORWALK, CT (SCHUPACK)  
 SEATECH CORP. MIAMI, FL (PERONI)  
 SHELL DEVELOPMENT CO. Houston TX (C. Sellars Jr.)

SWEDEN VBB (Library), Stockholm  
TEXTRON INC BUFFALO, NY (RESEARCH CENTER LIB.)  
TRW SYSTEMS REDONDO BEACH, CA (DAD)  
UNITED KINGDOM Cement & Concrete Assoc Wexham Springs, Slough Bucks: Library, Bristol; R. Browne,  
Southall, Middlesex; Taylor, Woodrow Constr (014P), Southall, Middlesex; Taylor, Woodrow Constr  
(Smith), Southall, Middlesex; Univ. of Bristol (R. Morgan), Bristol  
UNITED TECHNOLOGIES Windsor Locks CT (Hamilton Std Div., Library)  
WARD, WOISTENHOLD ARCHITECTS Sacramento, CA  
WESTINGHOUSE ELECTRIC CORP, Annapolis MD (Oceanic Div Lib, Bryant); Library, Pittsburgh PA  
WM CLAPP LABS - BATTELLE DUXBURY, MA (LIBRARY)  
BRAHTZ La Jolla, CA  
KETRON, BOB Ft Worth, TX  
KRUZIC, T.P. Silver Spring, MD  
CAPT MURPHY Sunnyvale, CA  
T.W. MERMEL Washington DC