

[54] **MULTI-CHIP CALCULATOR SYSTEM
HAVING CYCLE AND SUBCYCLE TIMING
GENERATORS**

[75] Inventors: **Michael J. Cochran**, Richardson;
Charles P. Grant, Jr., Dallas, both
of Tex.

[73] Assignee: **Texas Instruments Incorporated**,
Dallas, Tex.

[22] Filed: **Sept. 13, 1973**

[21] Appl. No.: **397,060**

[52] U.S. Cl. **235/152; 340/172.5**

[51] Int. Cl.² **G06F 1/04**

[58] Field of Search **235/152, 156; 340/172.5**

[56] **References Cited**
UNITED STATES PATENTS

3,798,606	3/1974	Henle et al.	340/172.5
3,800,129	3/1974	Umstaddt	235/156

Primary Examiner—David H. Malzahn
Attorney, Agent, or Firm—Harold Levine; Rene E.
Grossman; Thomas G. Devine

[57] **ABSTRACT**

An electronic protable calculator implemented in integrated circuit semiconductor technology utilizes cycle and subcycle timing generators on both the arithmetic chip and on the memory chip. One output terminal conveys both an internal operating condition of the arithmetic to other semiconductor calculator chips in the system including to the memory chip, and also conveys timing synchronization for the cycle and sub-cycle timing generators on the memory chip. The arithmetic chip also has means for generating a multi-bit command signal comprising a first set of bits representing internal conditions of the arithmetic chip and a second set of bits selectively representing a memory address location dependent upon bits in the first set.

13 Claims, 81 Drawing Figures

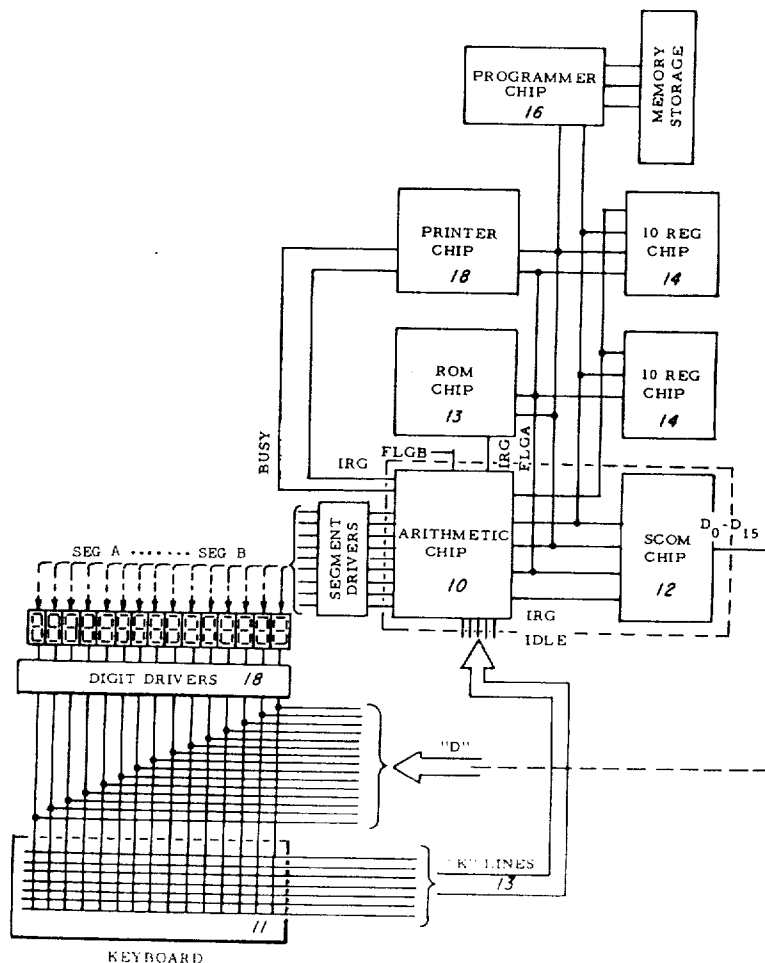

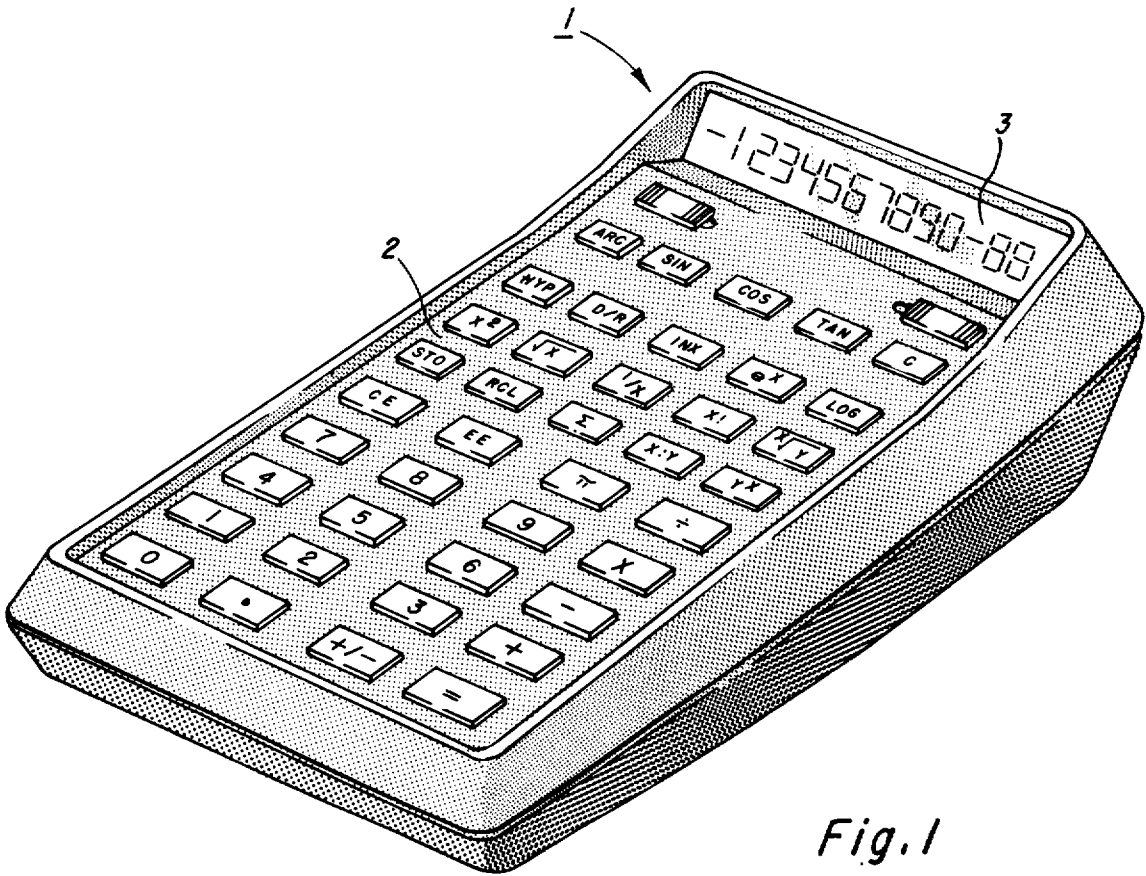

Fig. 1

Fig. 2

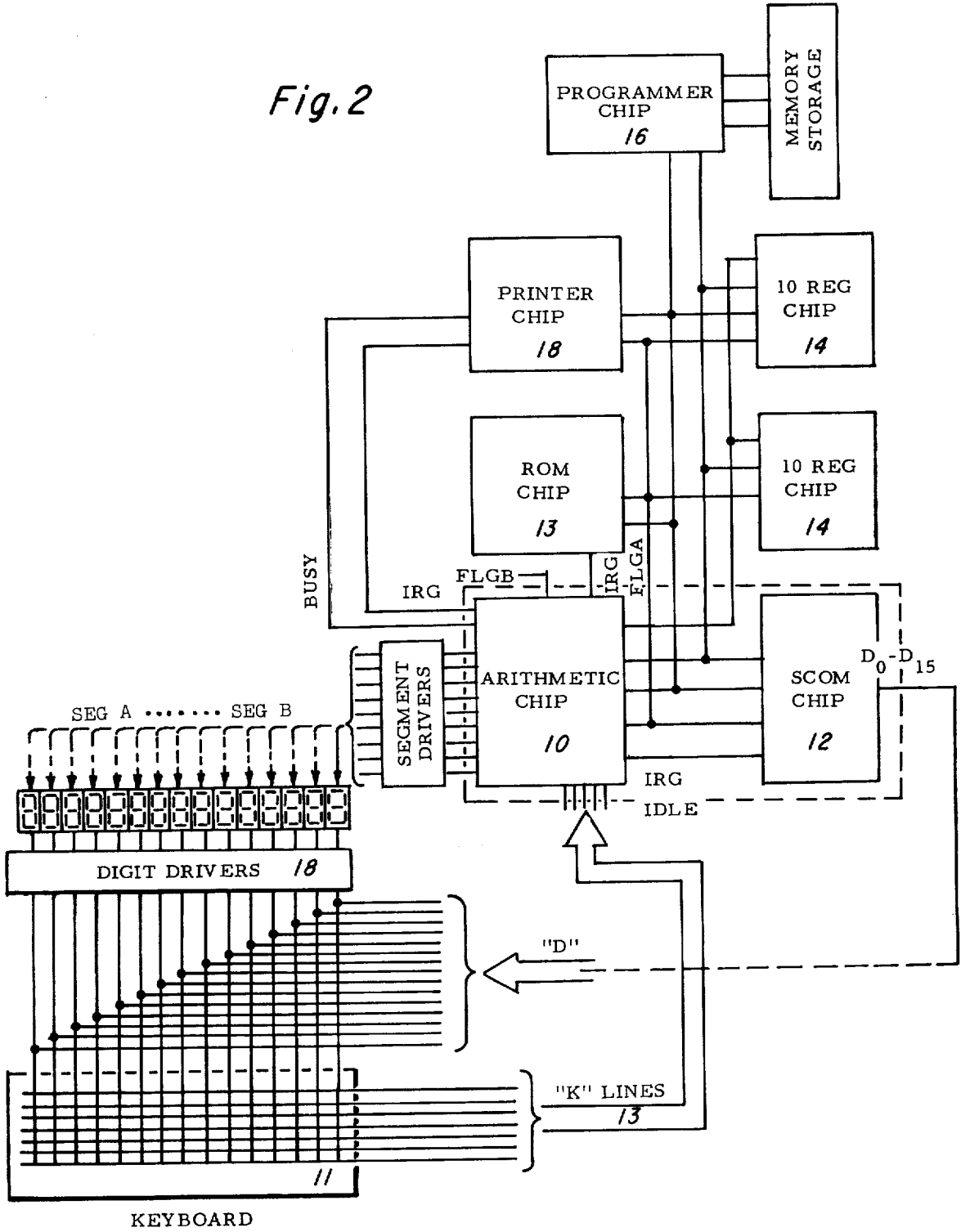

Fig. 3a

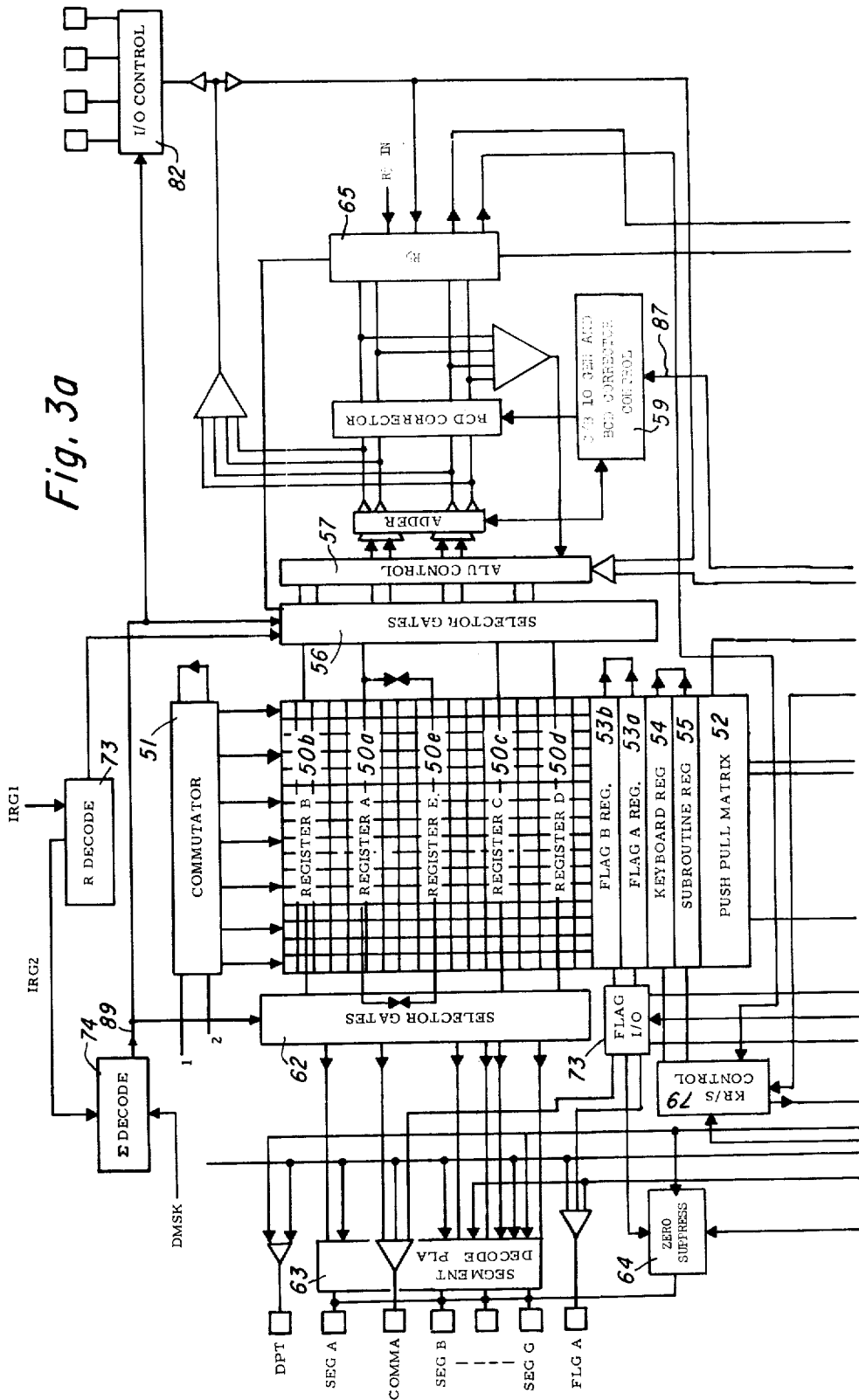
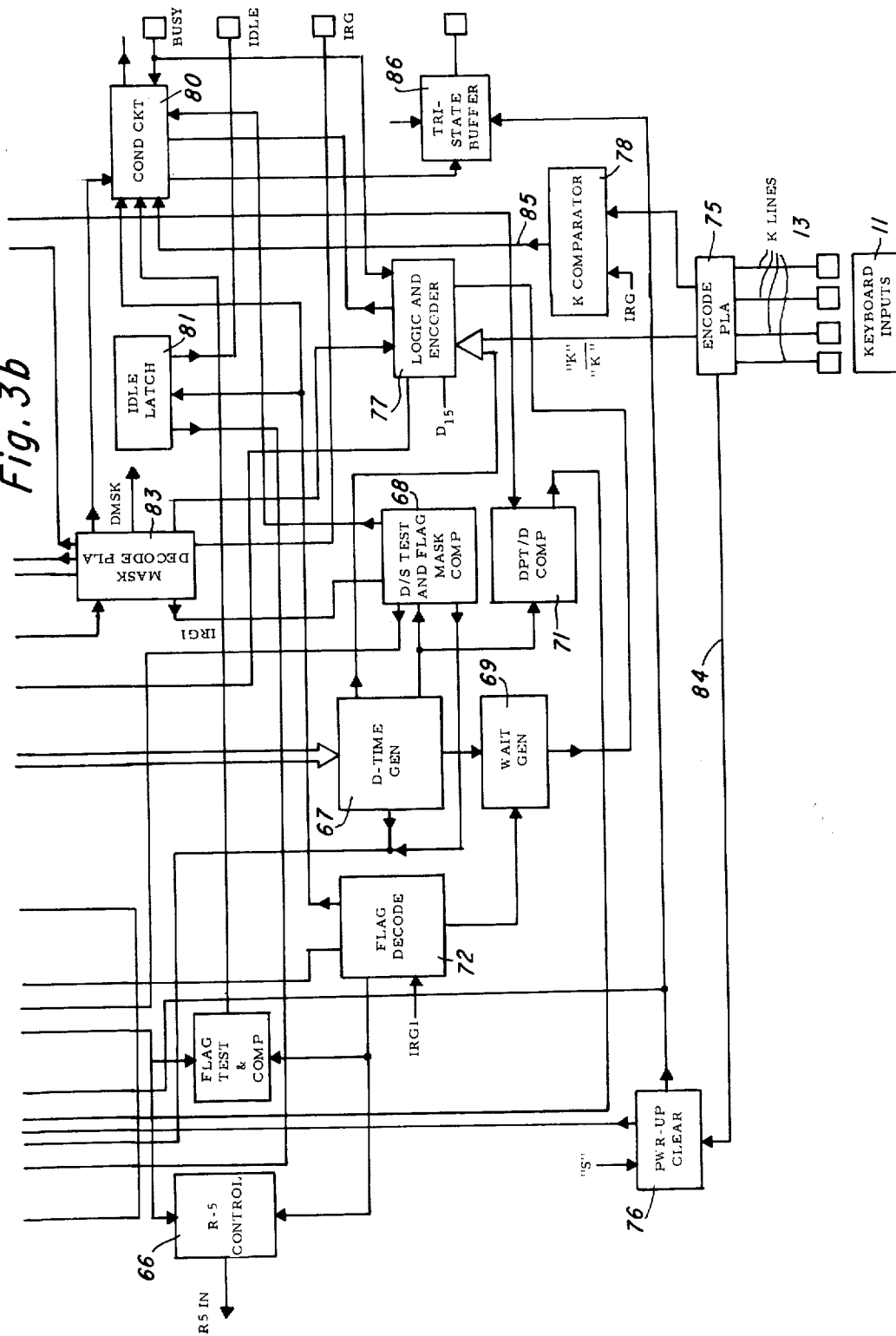

Fig. 3b



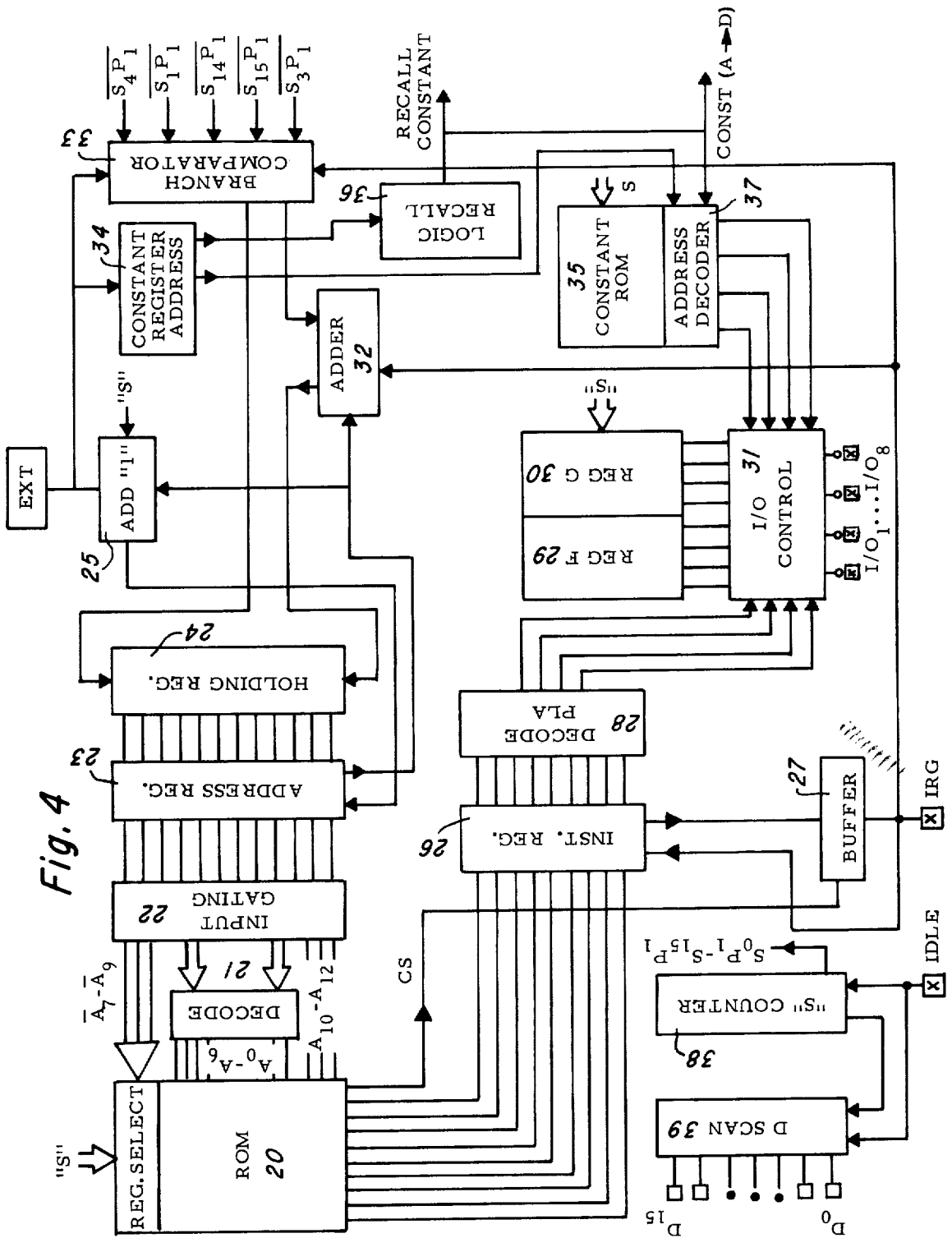
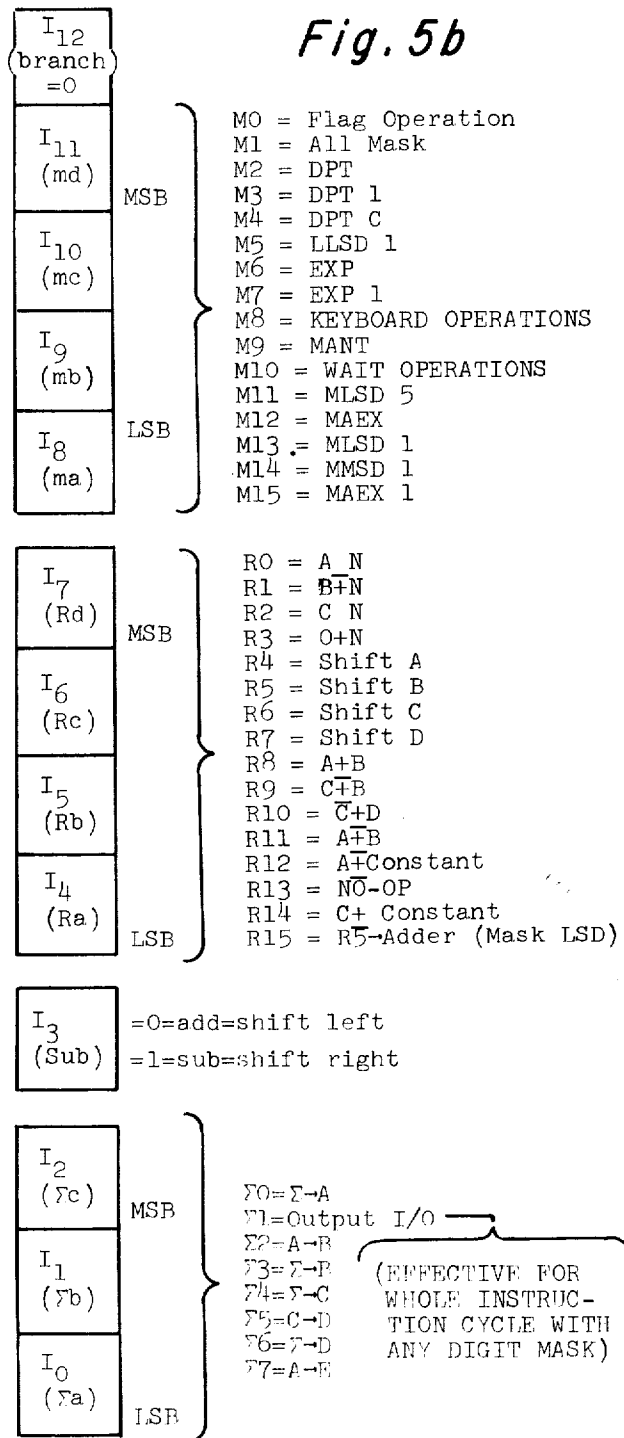
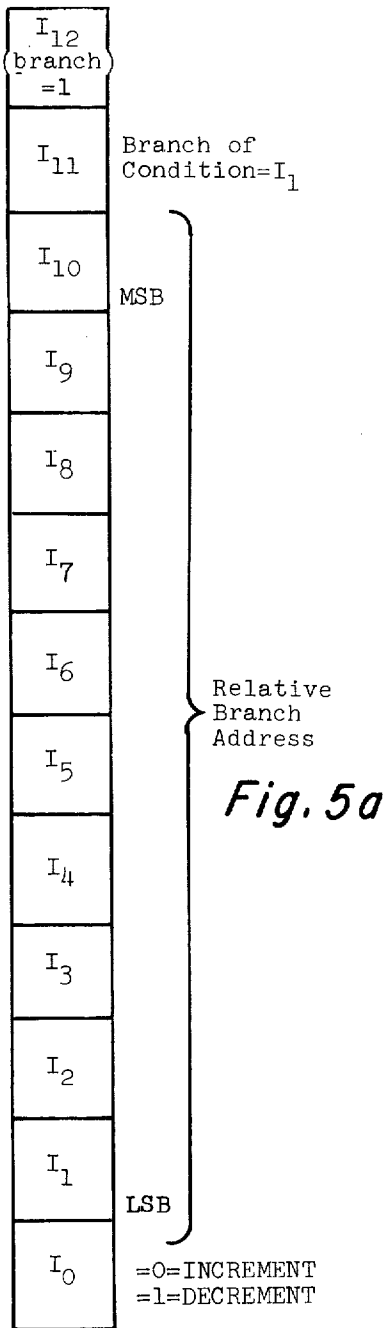
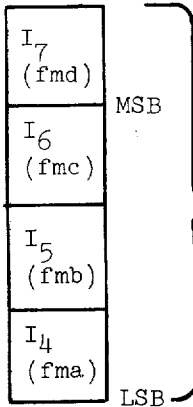

Fig. 4



The following 8 bits effective only if flag operations



Generate FlagMask when these 4 bits equal the 4 encoded state bits.
(NOTE: ENCODED STATE TIMES ARE +2 FROM ACTUAL STATES)

The following 8 bits effective only if Keyboard operations

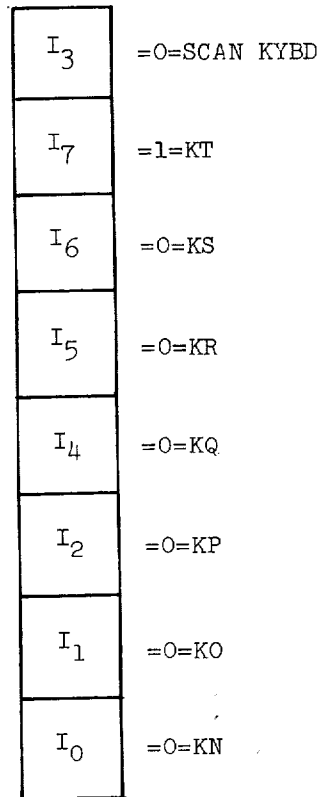

The following 4 bits (flagops) effective only during flagmask except f₁₄ & f₁₅

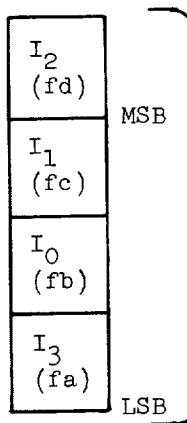

- f₀ = TEST FLAG A
- f₁ = TEST FLAG B
- f₂ = SET FLAG A
- f₃ = SET FLAG B
- f₄ = ZERO FLAG A
- f₅ = ZERO FLAG B
- f₆ = INVERT FLAG A
- f₇ = INVERT FLAG B
- f₈ = EXCH. FLAG A B
- f₉ = COMPARE FLAG A B
- f₁₀ = SET FLAG KR
- f₁₁ = ZERO FLAG KR
- f₁₂ = COPY FLAG B→A
- f₁₃ = COPY FLAG A→B
- f₁₄ = REG 5→FLAG A SO S3
- f₁₅ = REG 5→FLAG B SO S3

Fig. 5d

Fig. 5c

Fig. 5f

The following 8 bits effective only if wait operations

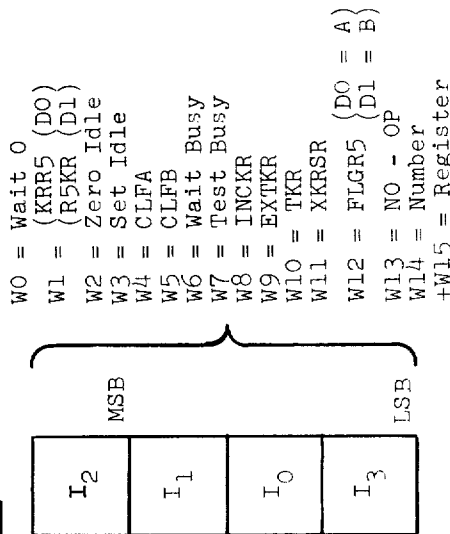

Fig. 5e

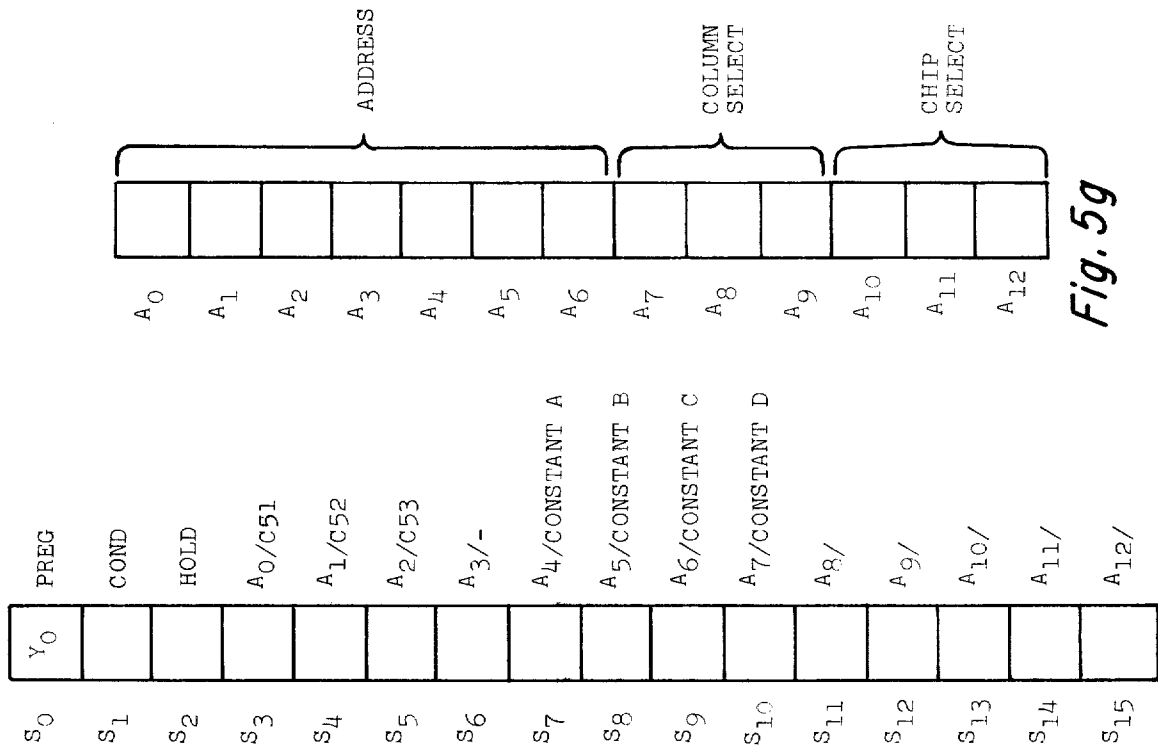
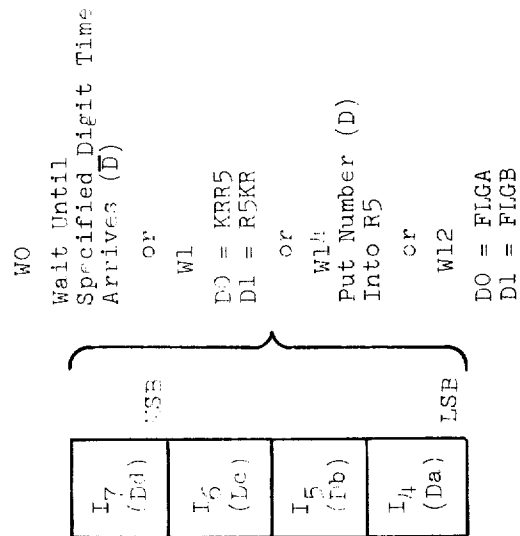

Fig. 5g

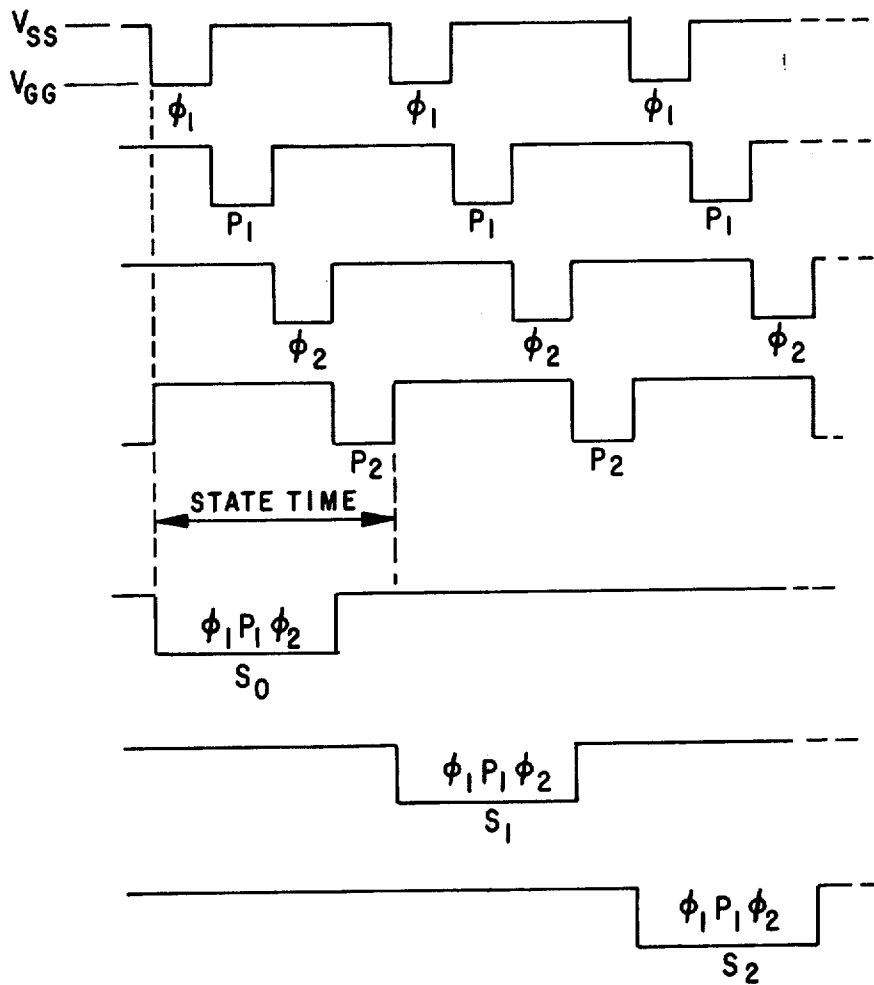

Fig. 6a

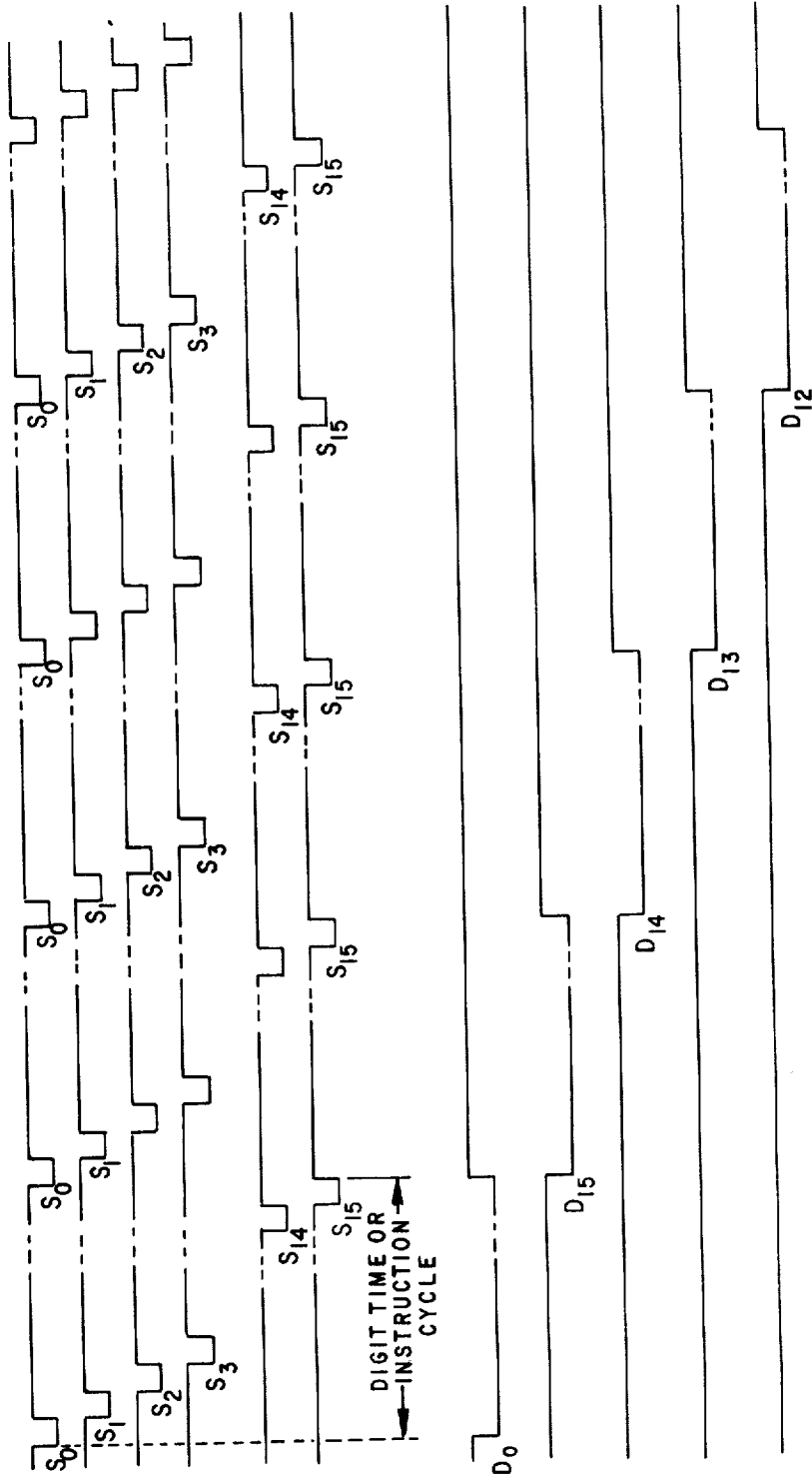

Fig. 6b

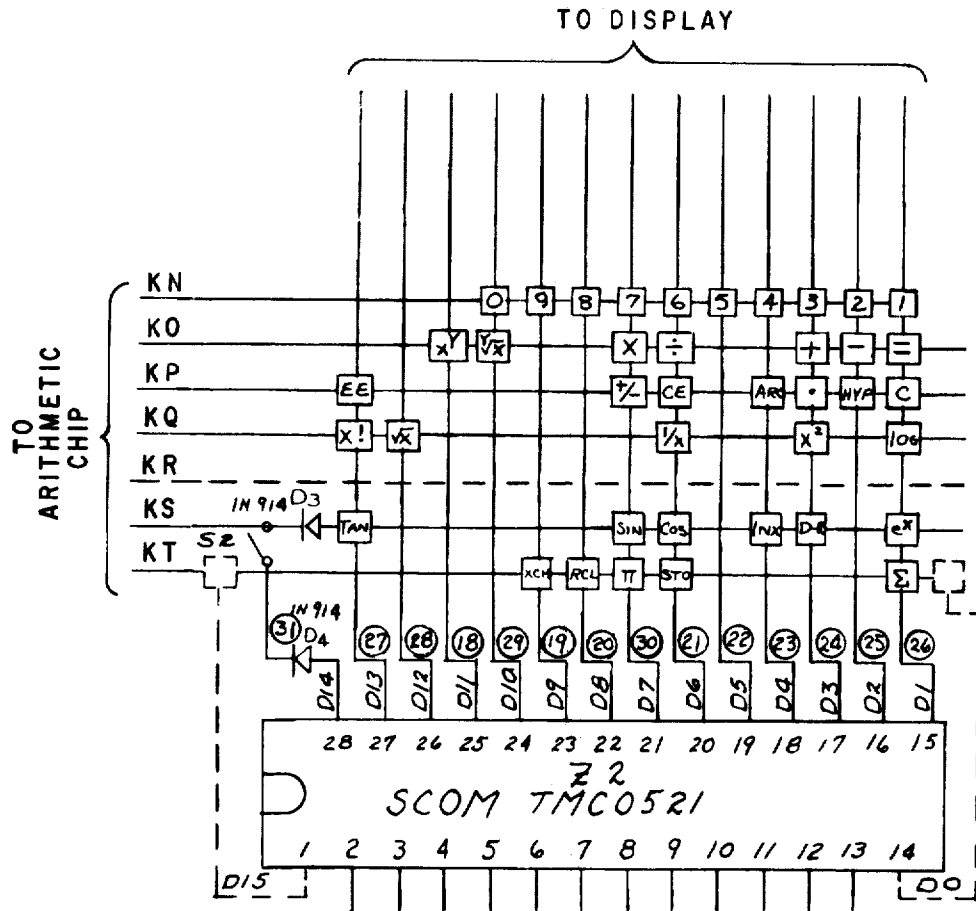

Fig. 7

Fig. 8b1	Fig. 8b2	Fig. 8b3	Fig. 8b4	Fig. 8b5
Fig. 8b6	Fig. 8b7	Fig. 8b8	Fig. 8b9	Fig. 8b10

Fig. 8a

Fig. 8c1	Fig. 8c2	Fig. 8c3	Fig. 8c4
Fig. 8c5	Fig. 8c6	Fig. 8c7	Fig. 8c8

Fig. 8d1	Fig. 8d2	Fig. 8d3
Fig. 8d4	Fig. 8d5	Fig. 8d6

Fig. 8b1

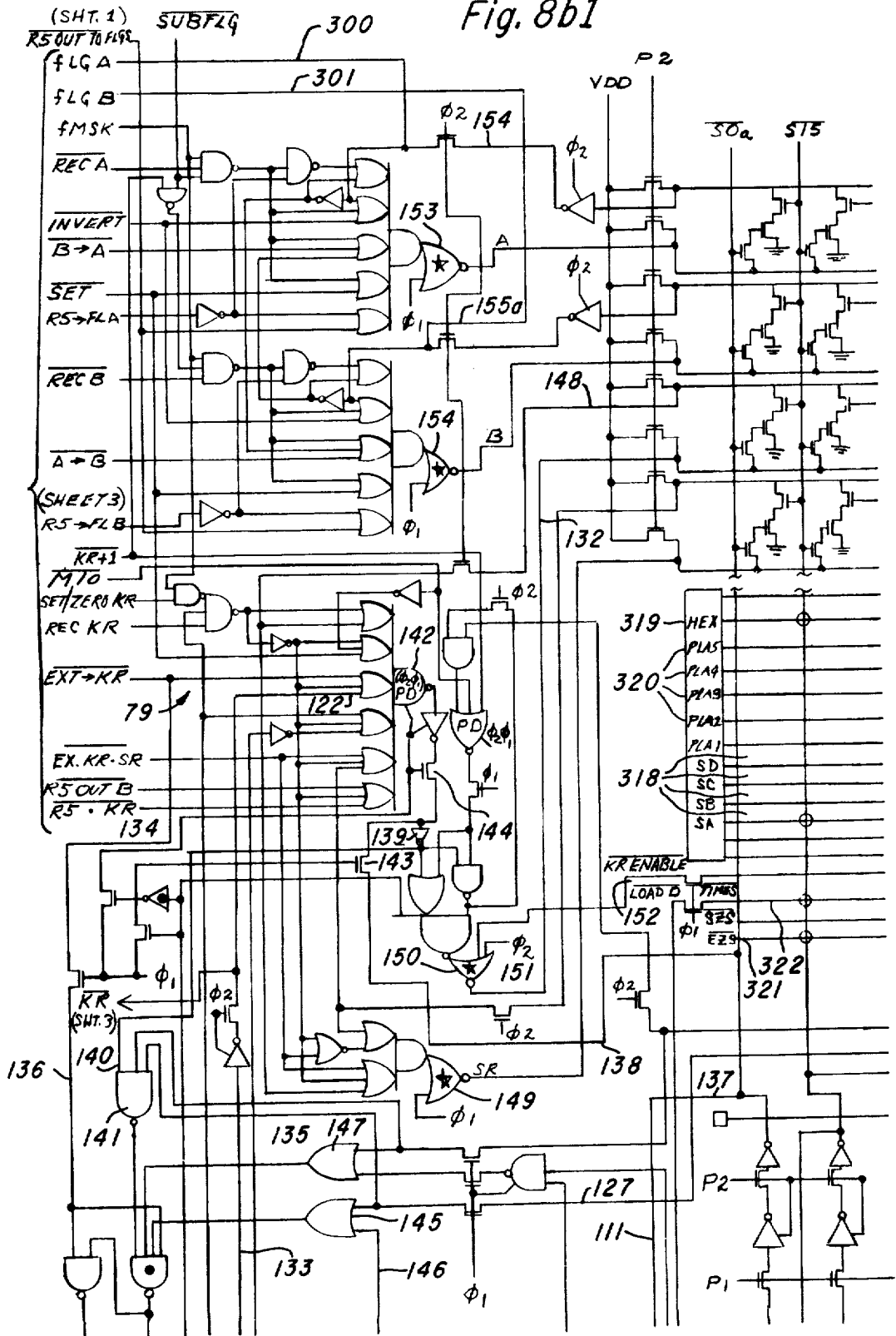

(SHEET 1) Fig. 8b2

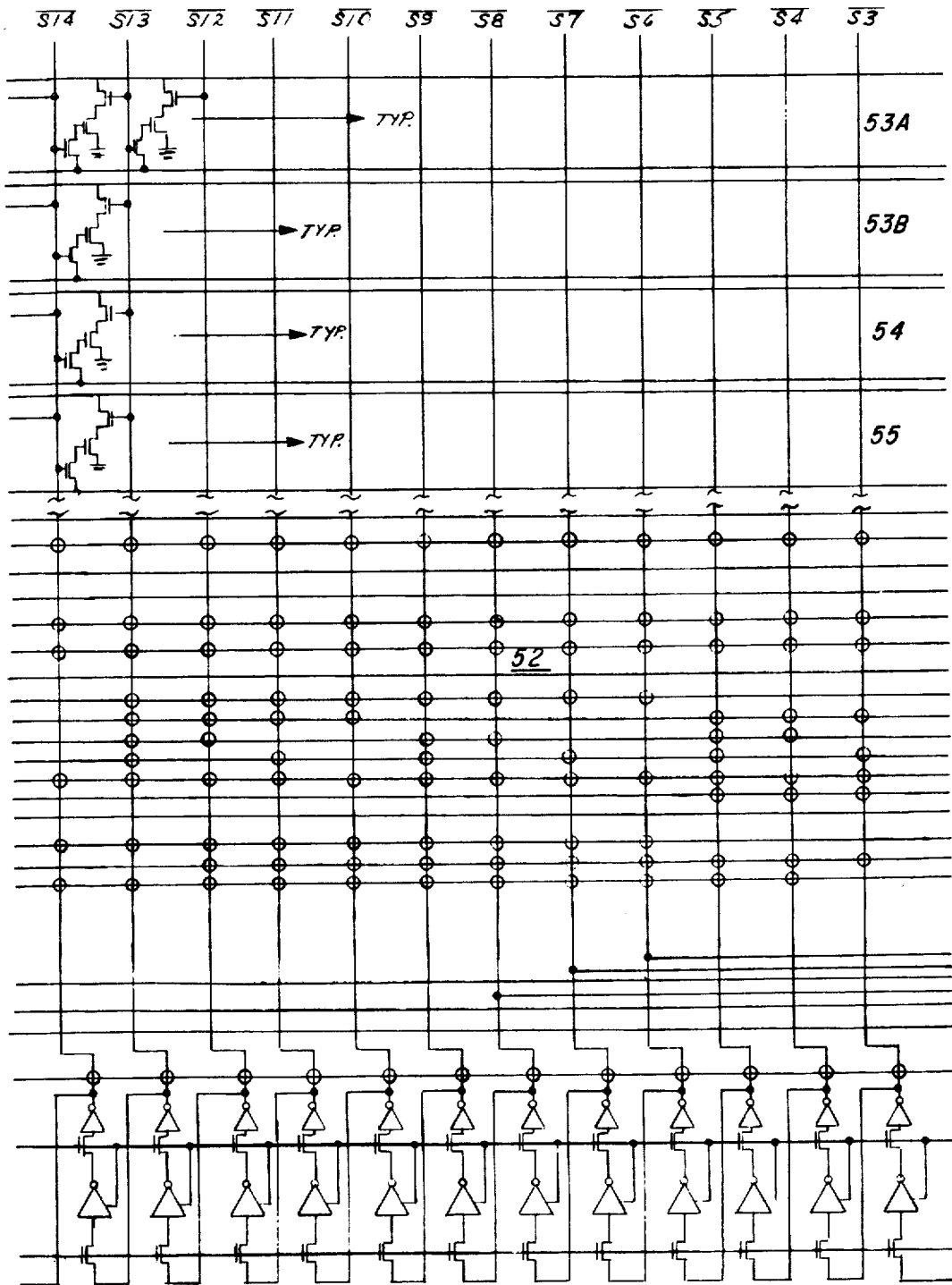

(SHEET 1)

Fig. 8b3 (SHT. 3)
 $\sum O(P_1)$

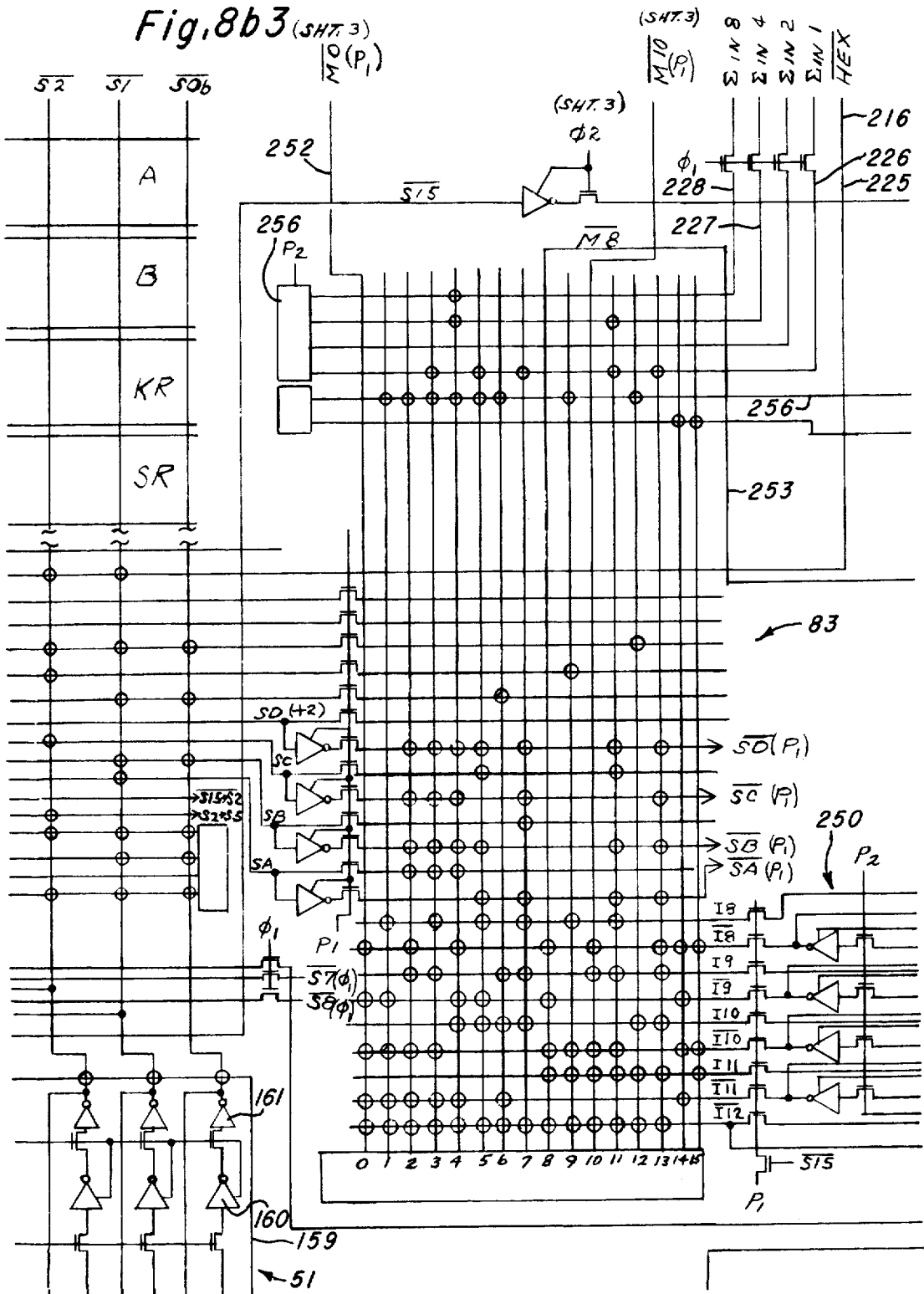

Fig. 8b4

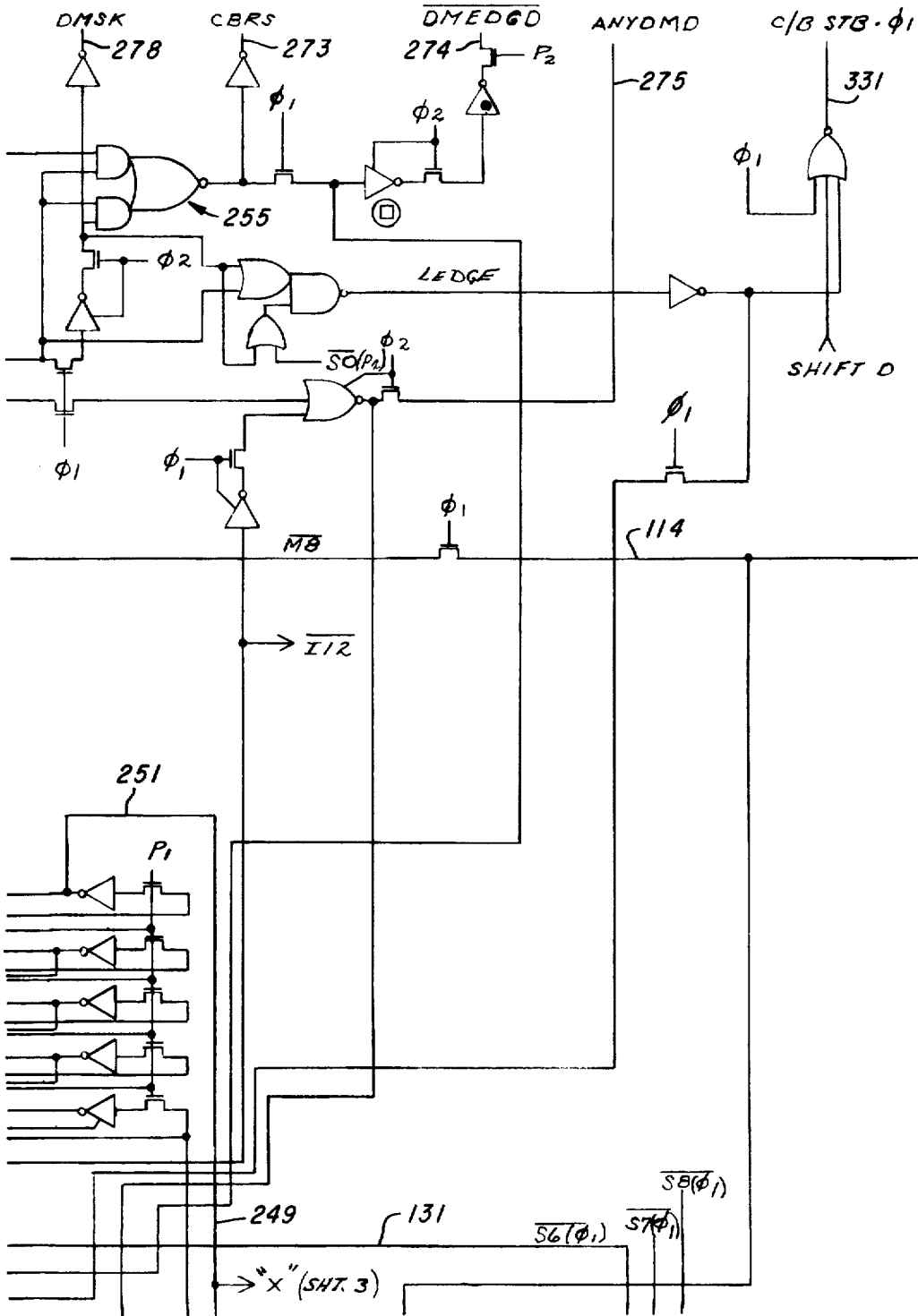
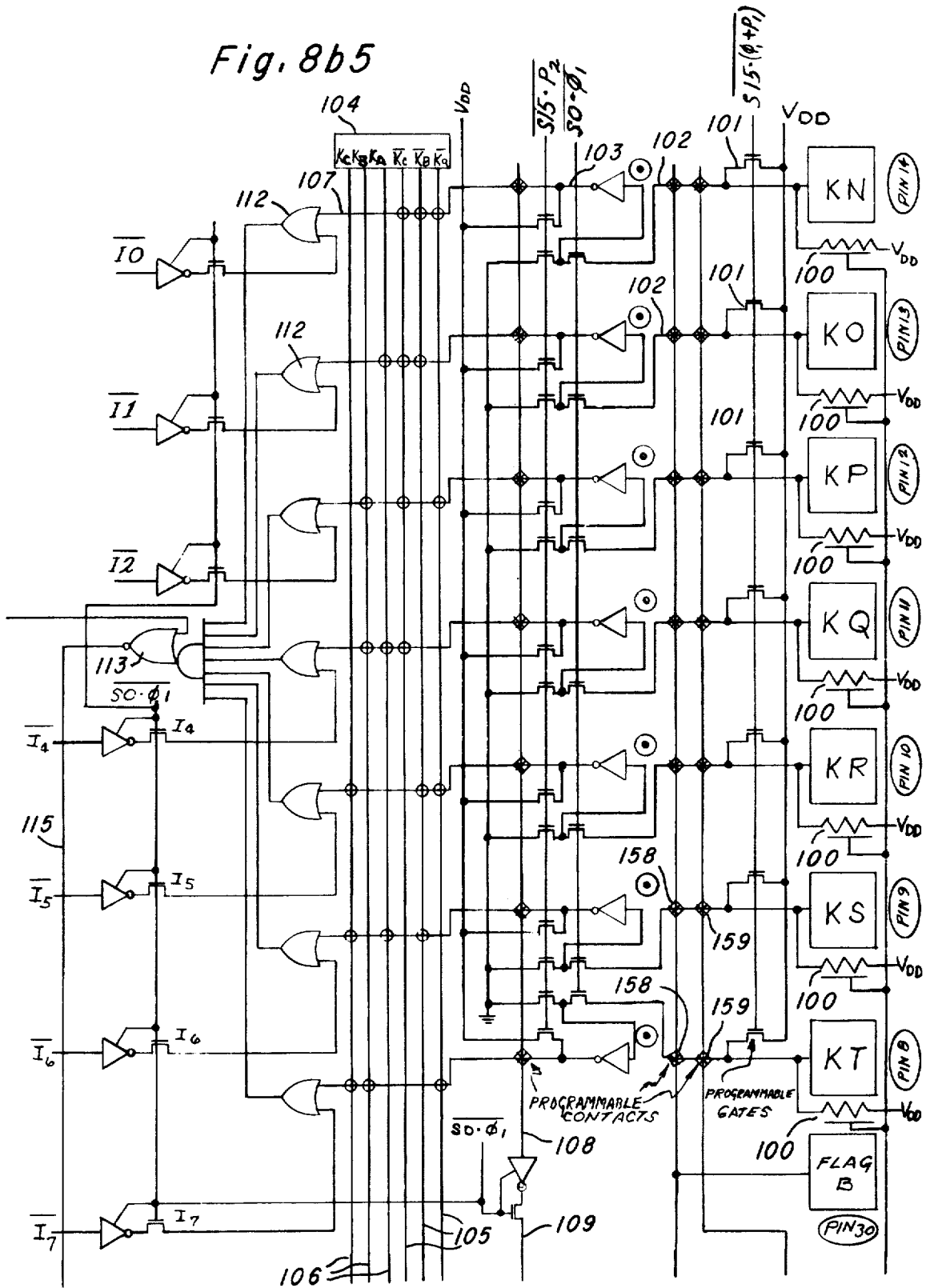

Fig. 8b5



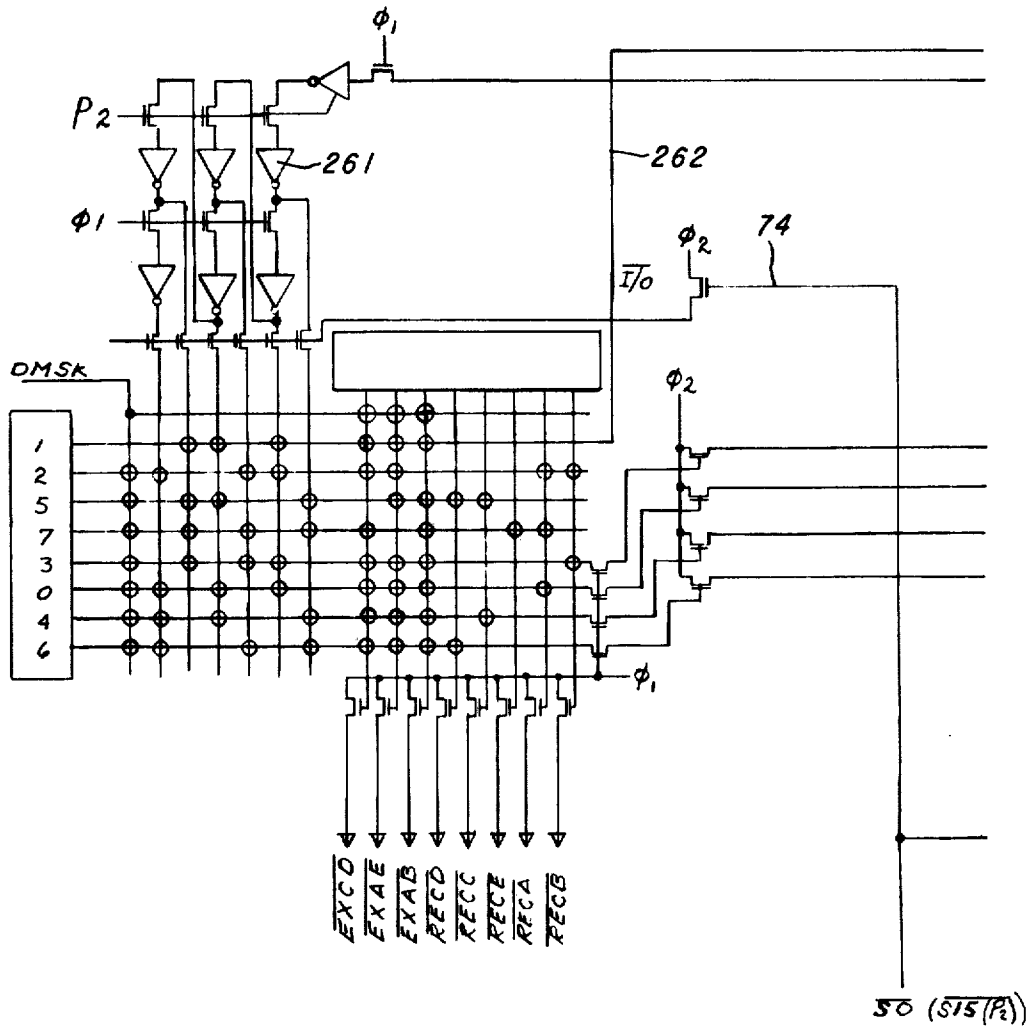
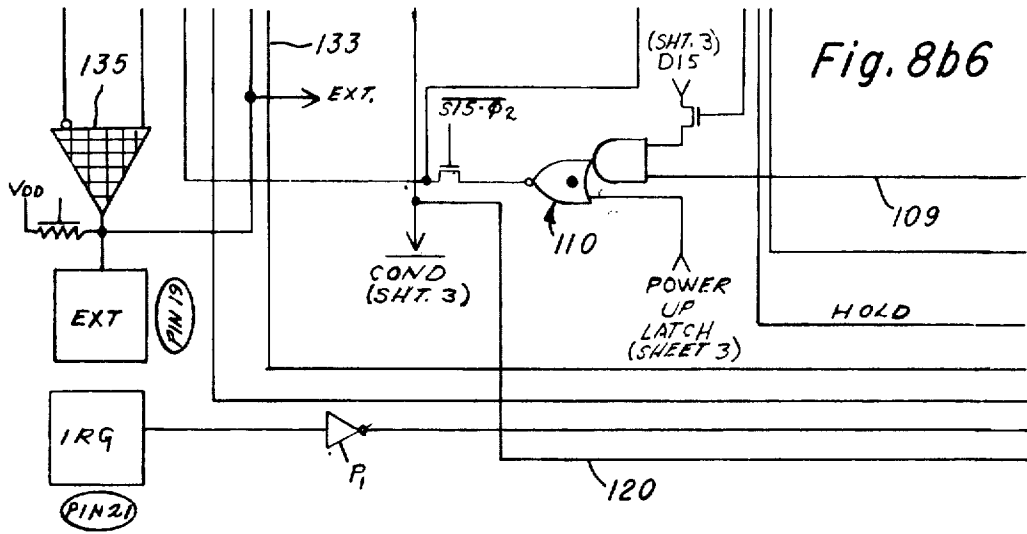

Fig. 8b7

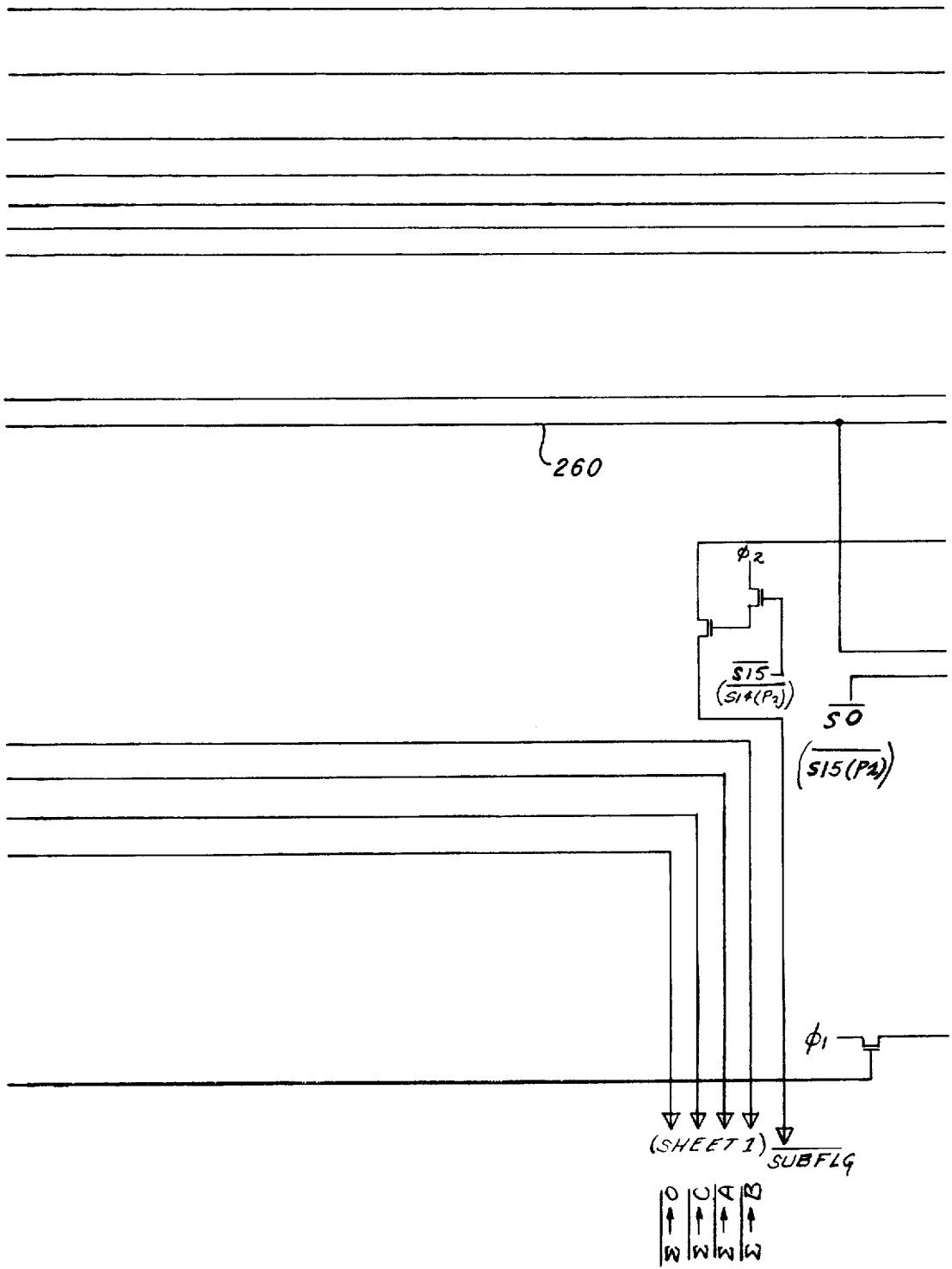
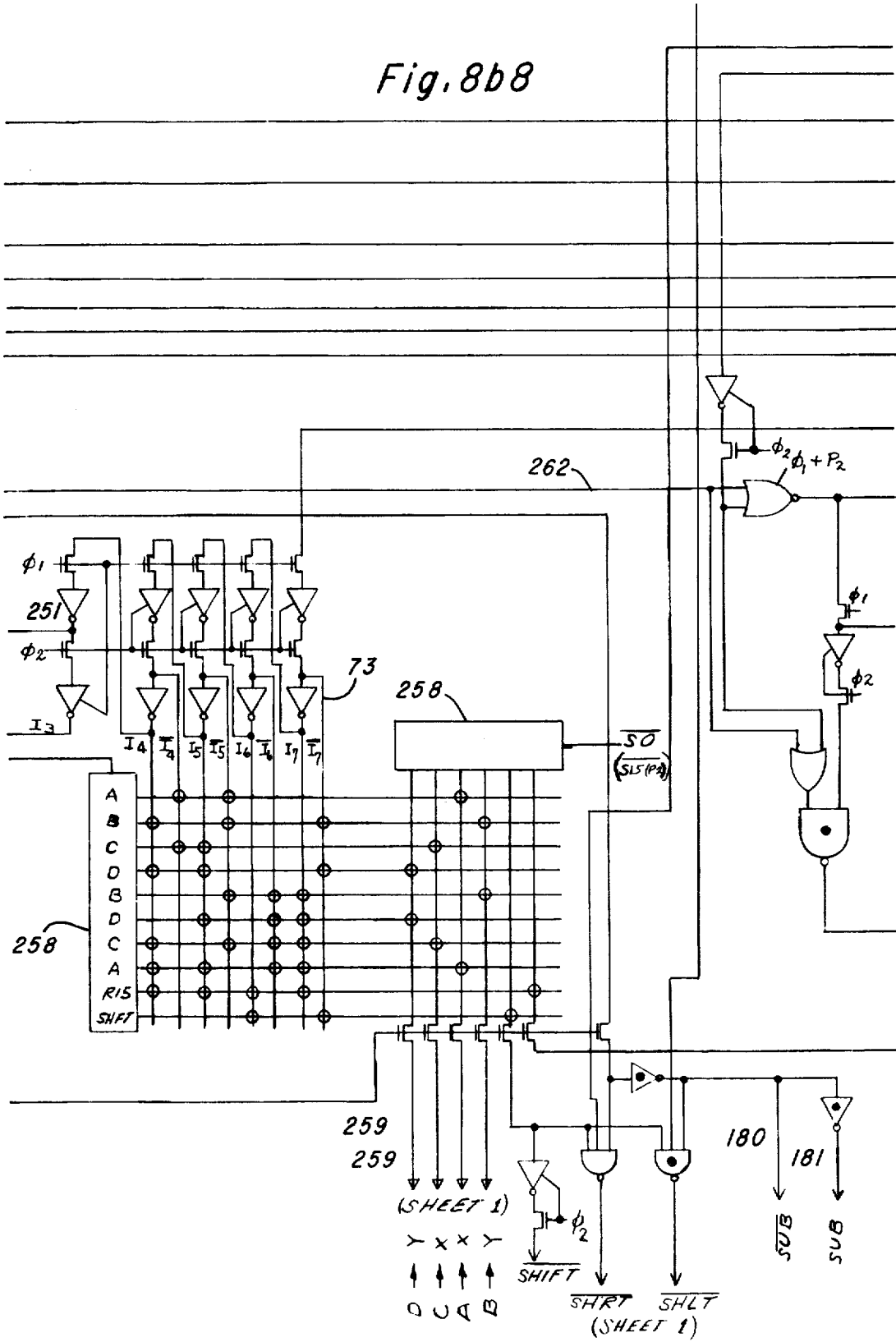
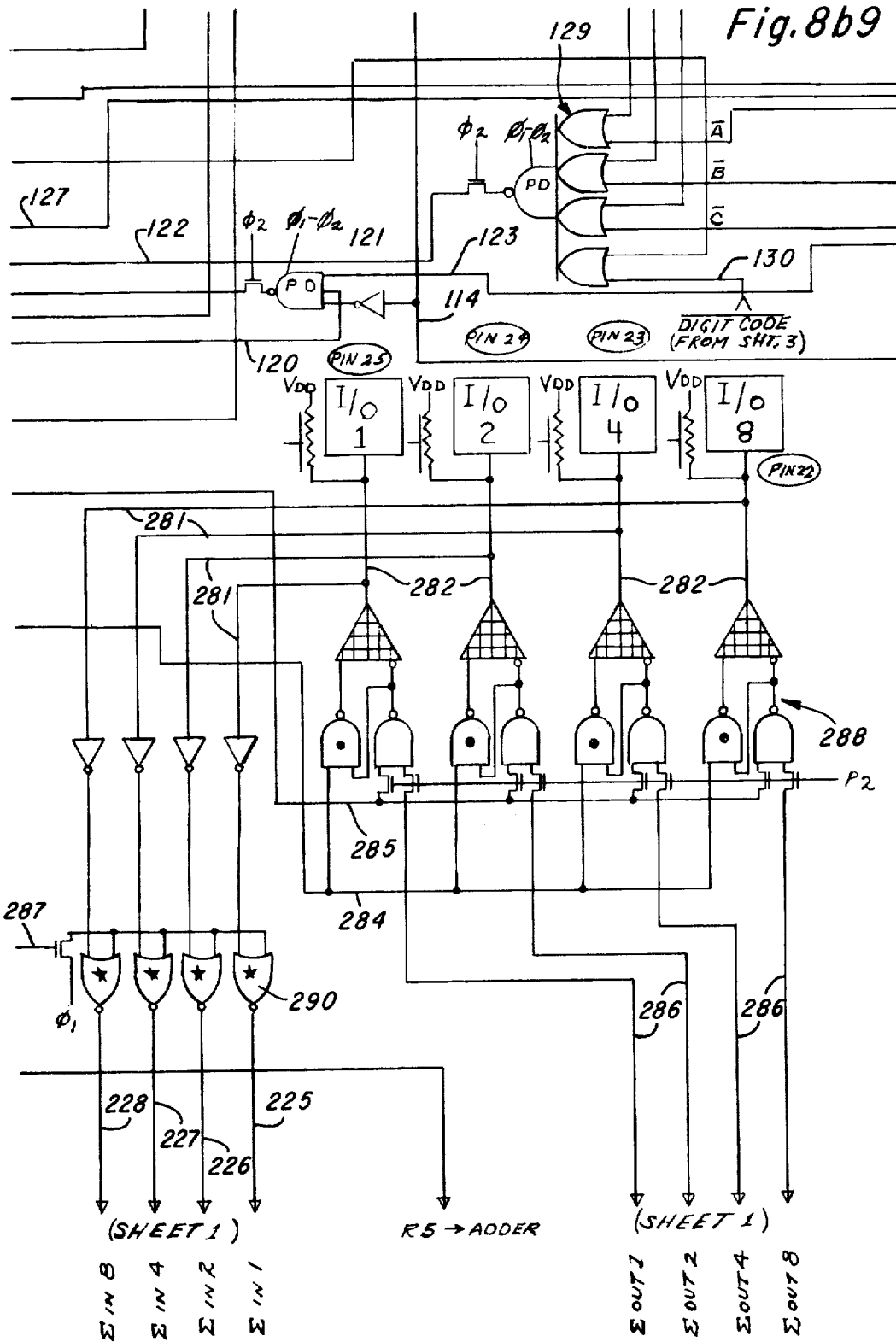

Fig. 8b8





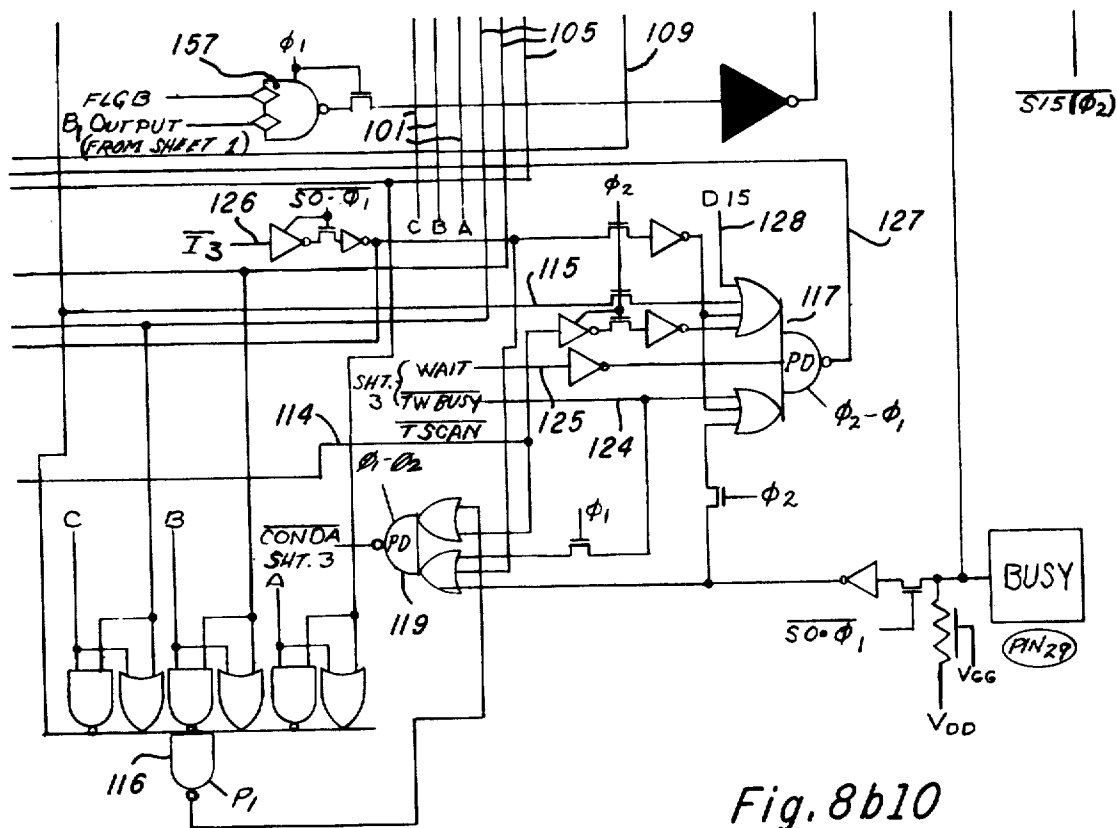

Fig. 8b10

Fig. 8c1

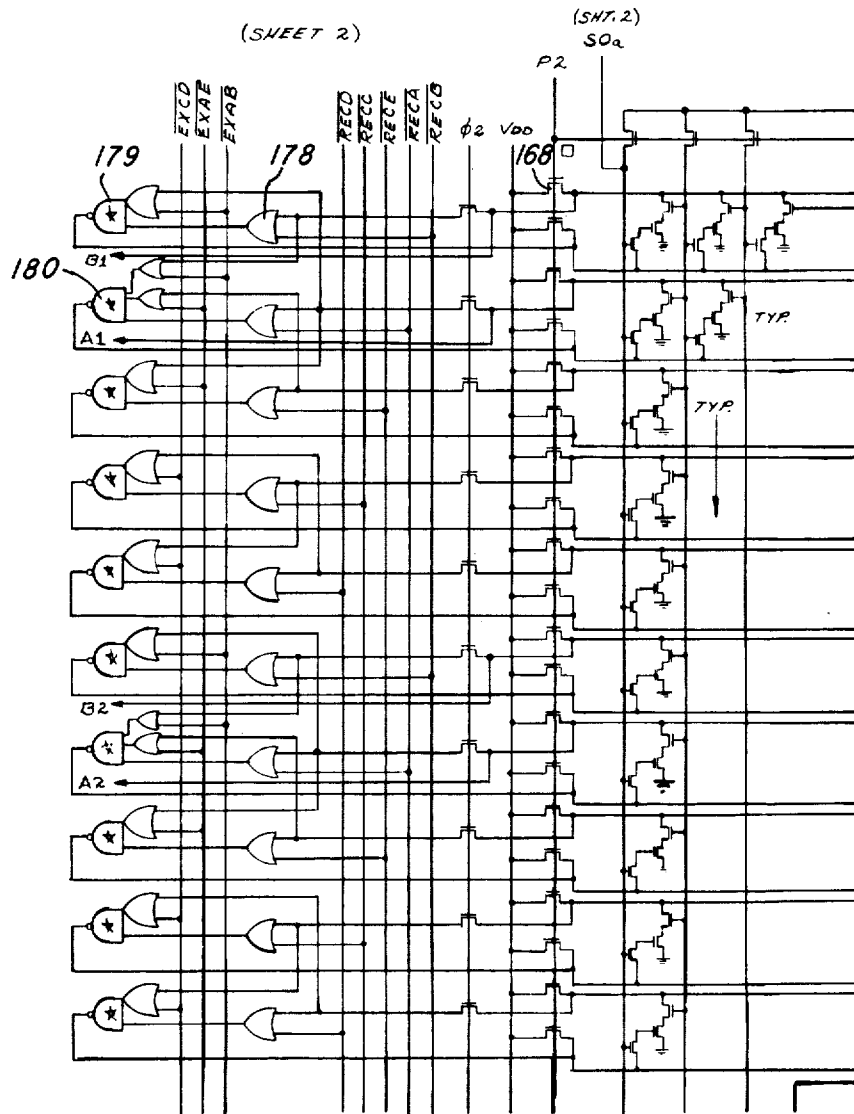

Fig. 8c2

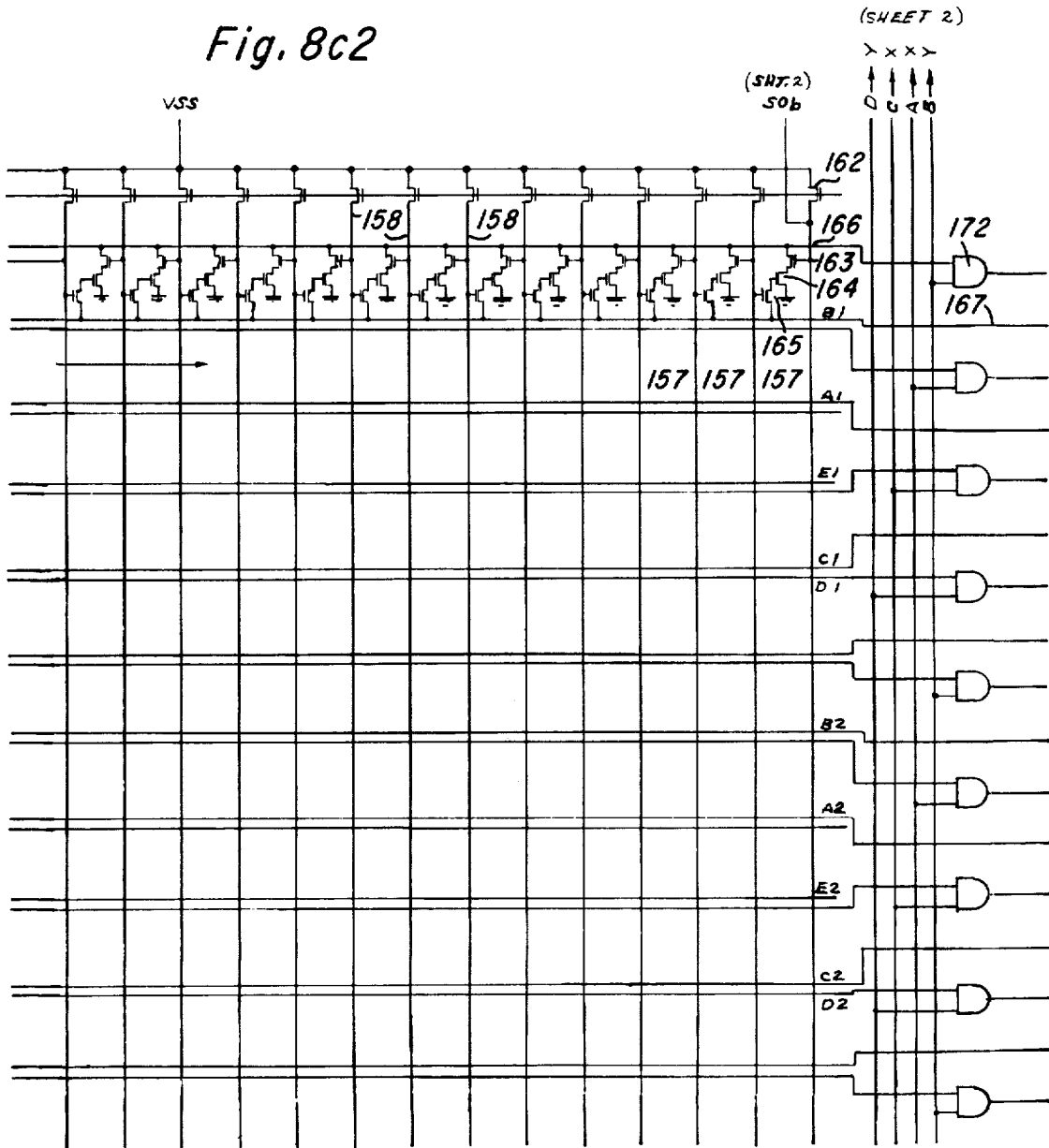

Fig. 8c3

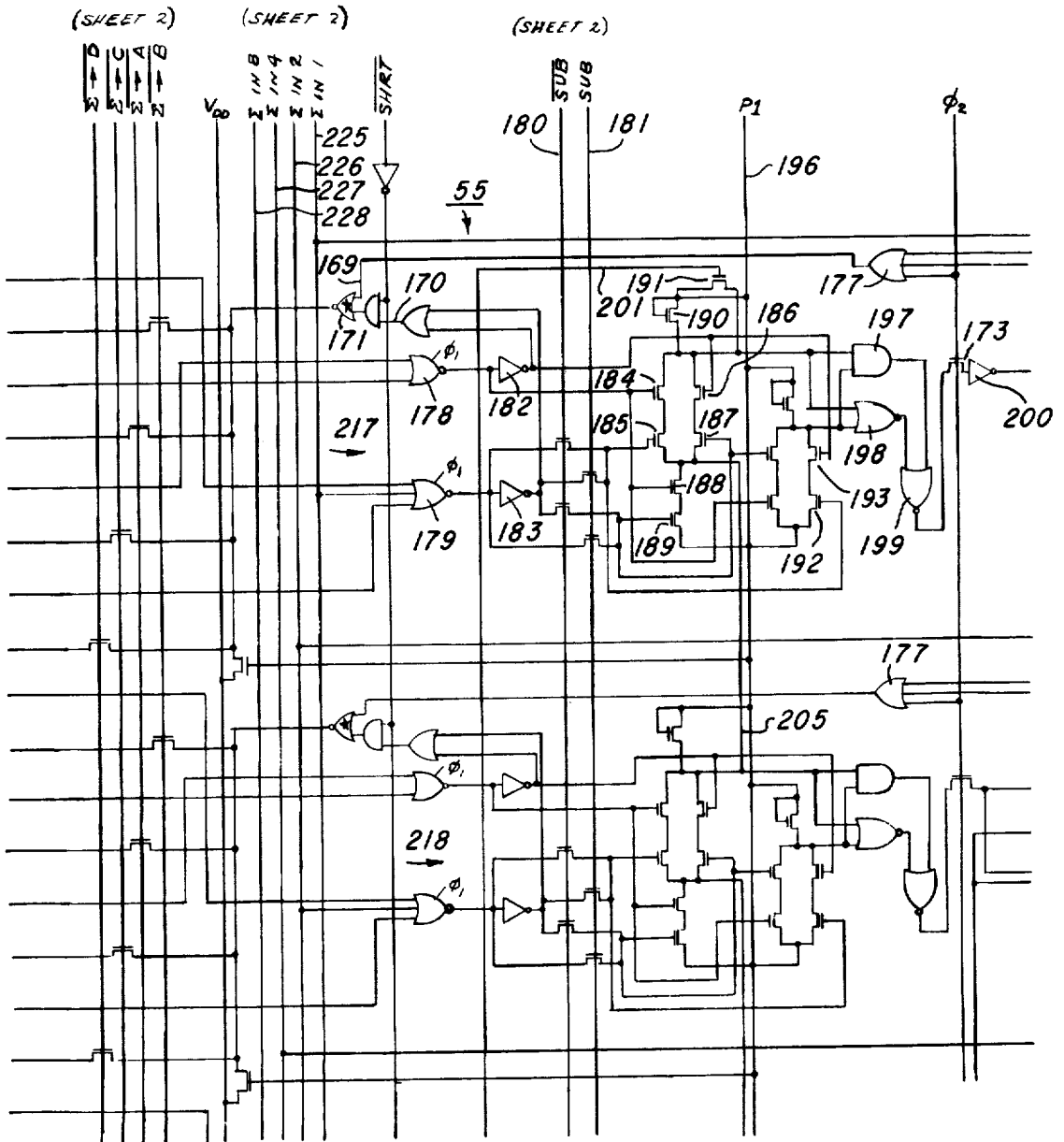

Fig. 8c4

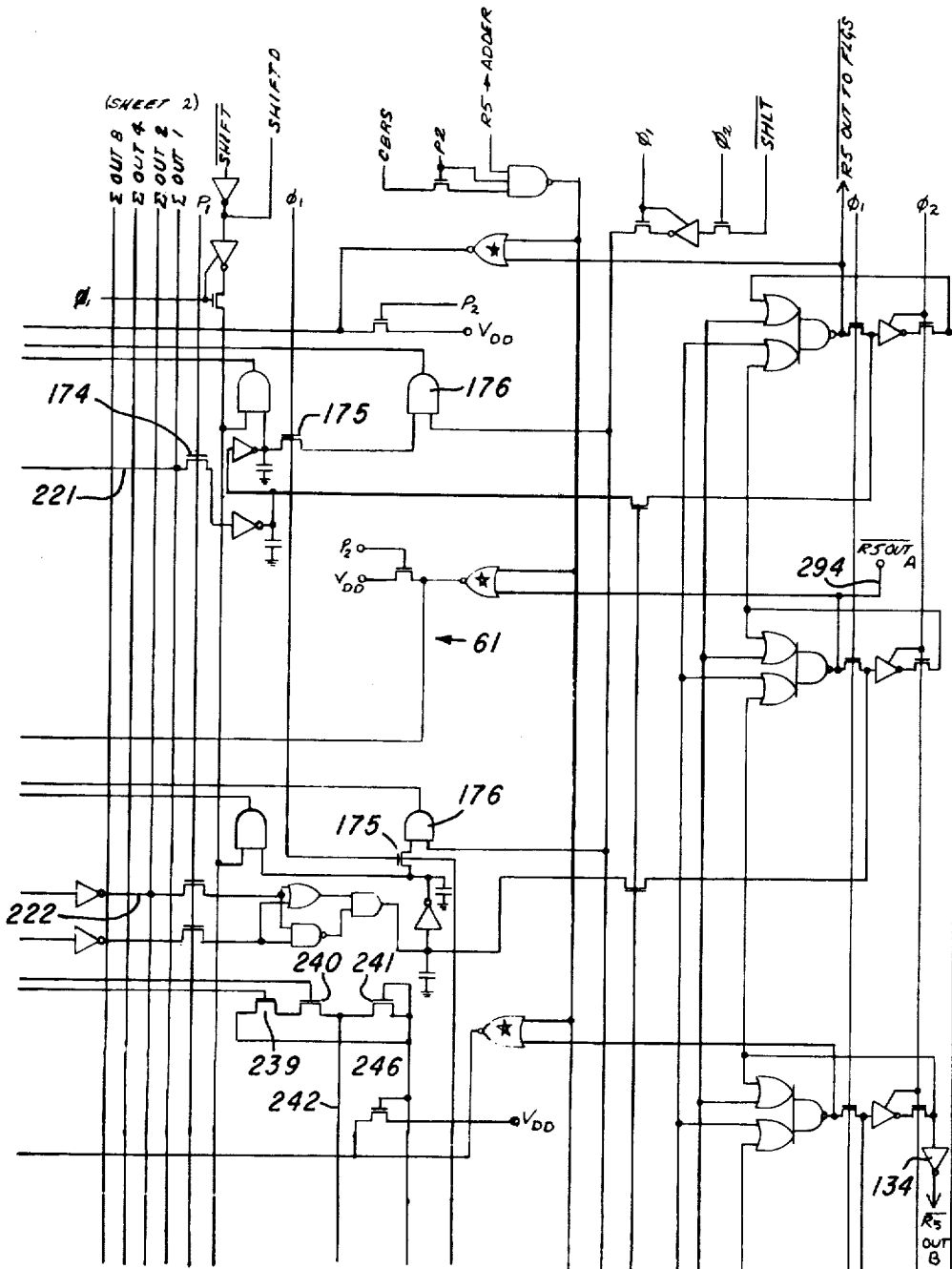

Fig. 8c5

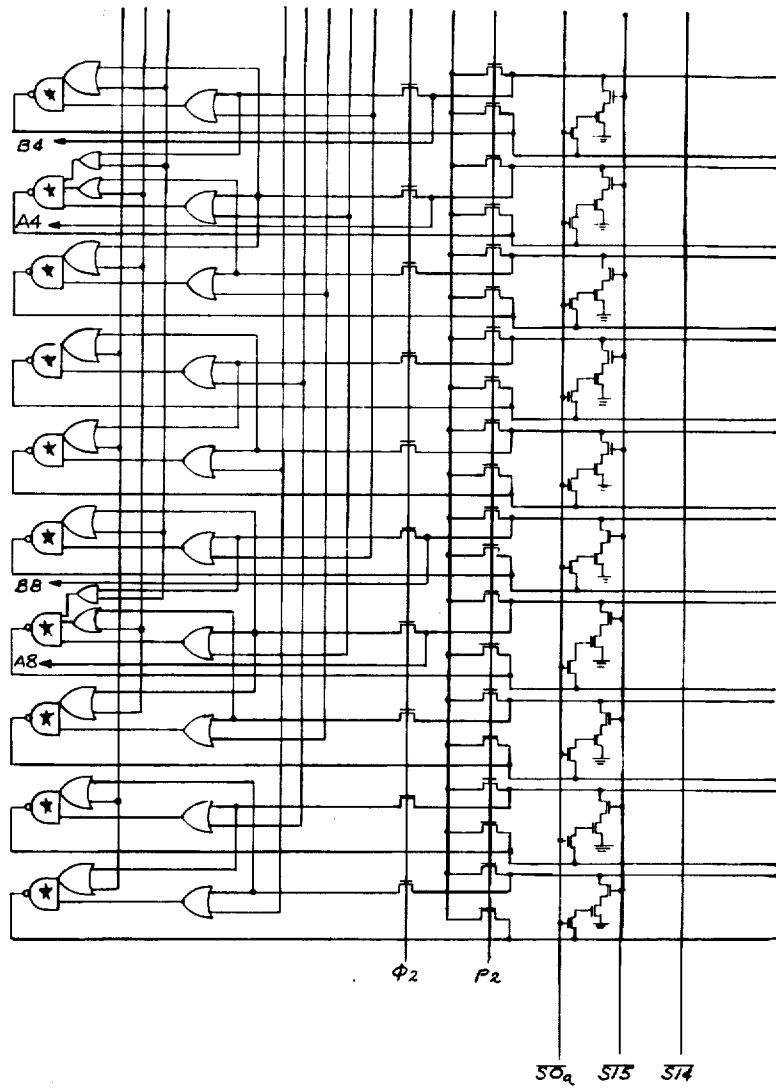
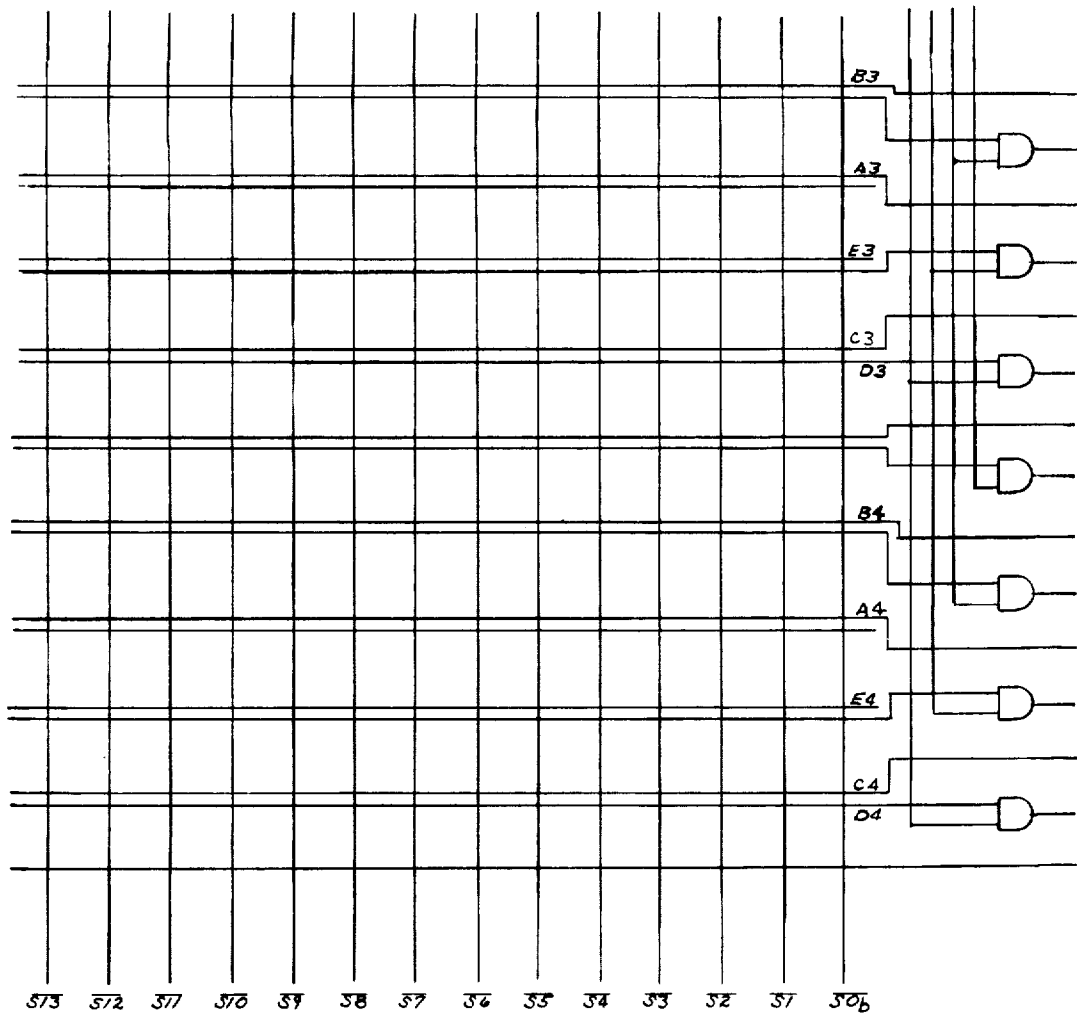

Fig. 8c6



(SHEET 2)

Fig. 8c7

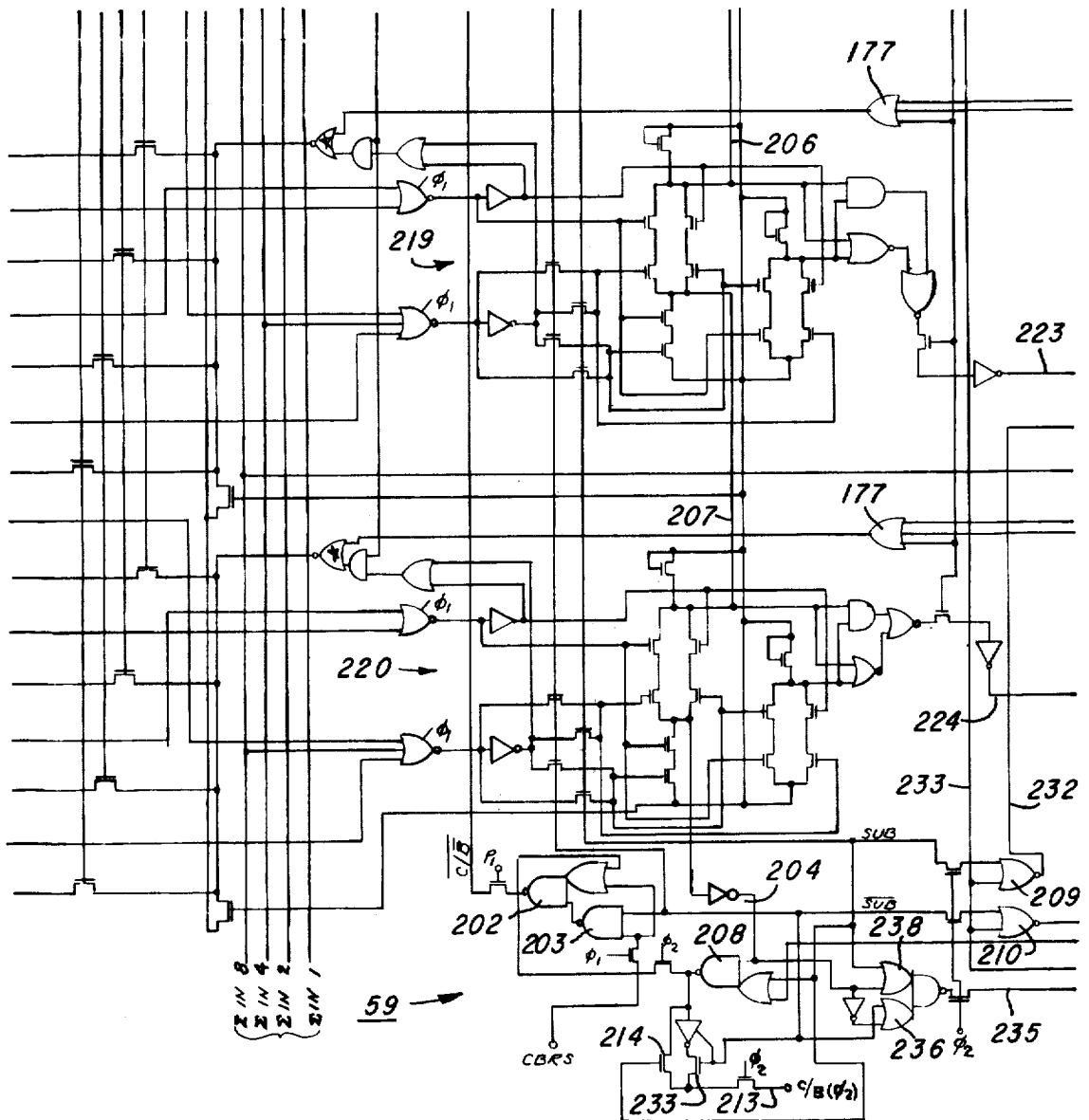

Fig. 8c8

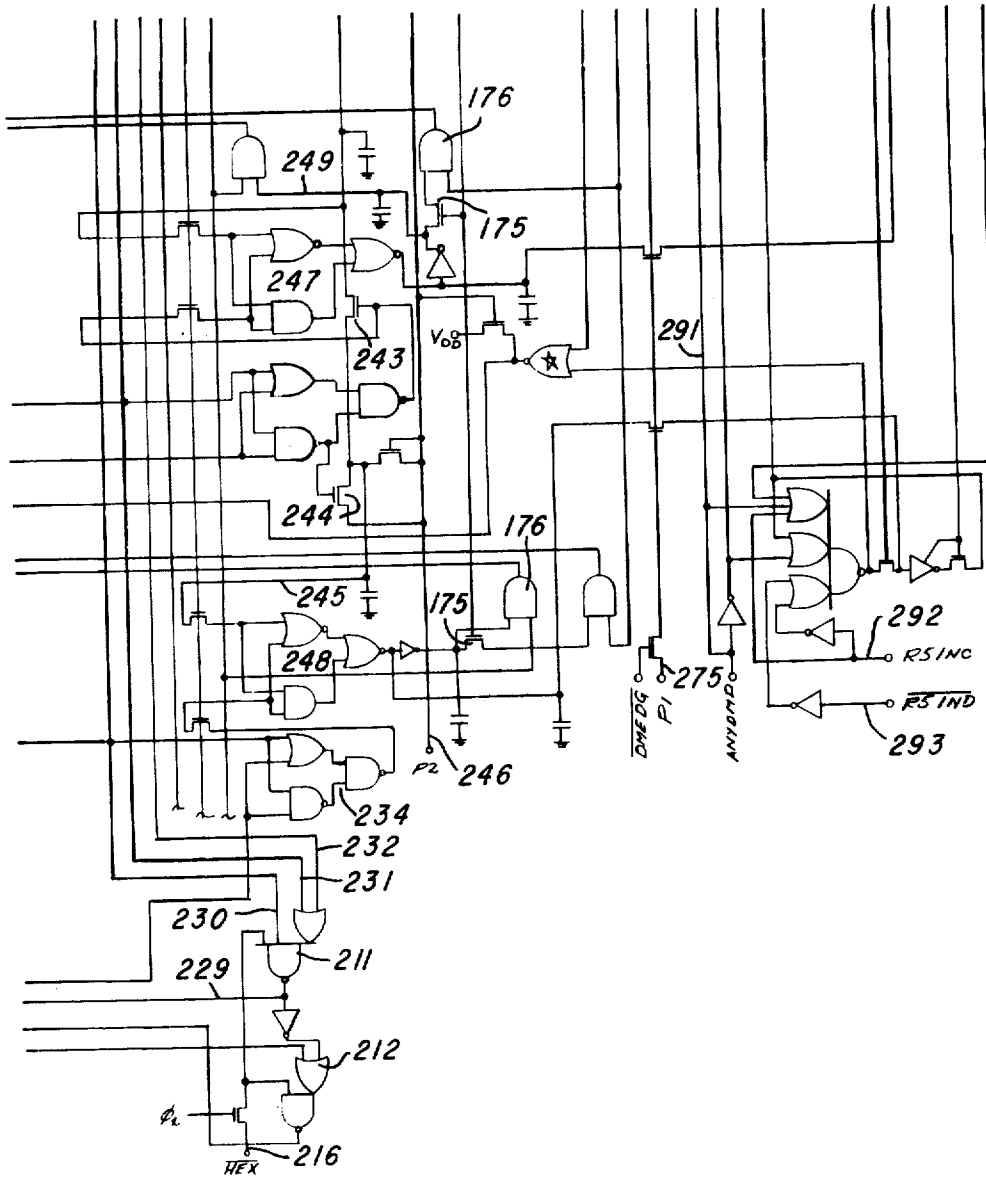

Fig. 9b1	Fig. 9b2
Fig. 9b3	Fig. 9b4

Fig. 9a

Fig. 9c1	Fig. 9c2
Fig. 9c3	Fig. 9c4

Fig. 9d1	Fig. 9d2	Fig. 9d3	Fig. 9d4
Fig. 9d5	Fig. 9d6	Fig. 9d7	Fig. 9d8

Fig. 9e1	Fig. 9e2	Fig. 9e3
Fig. 9e4	Fig. 9e5	Fig. 9e6

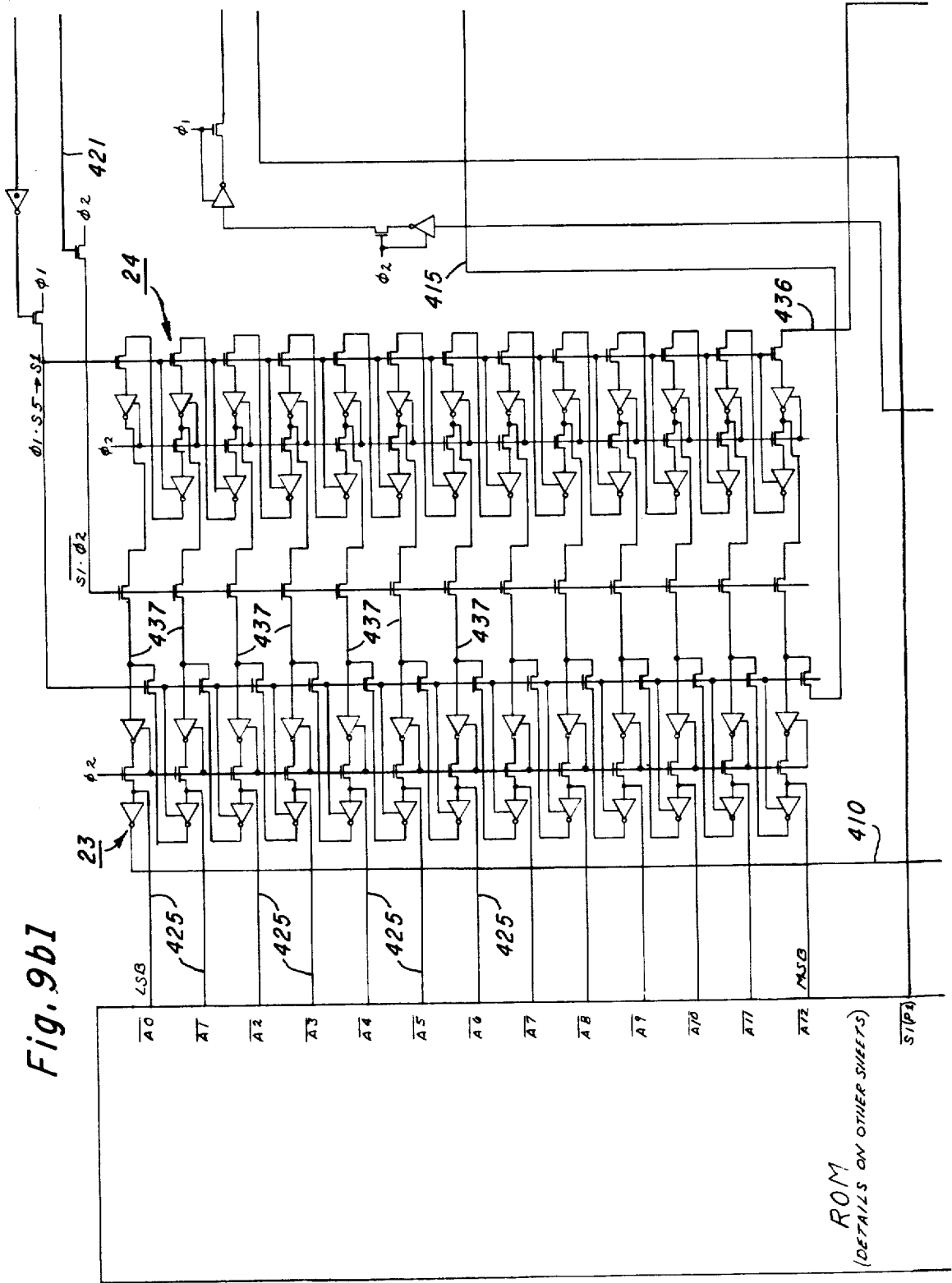
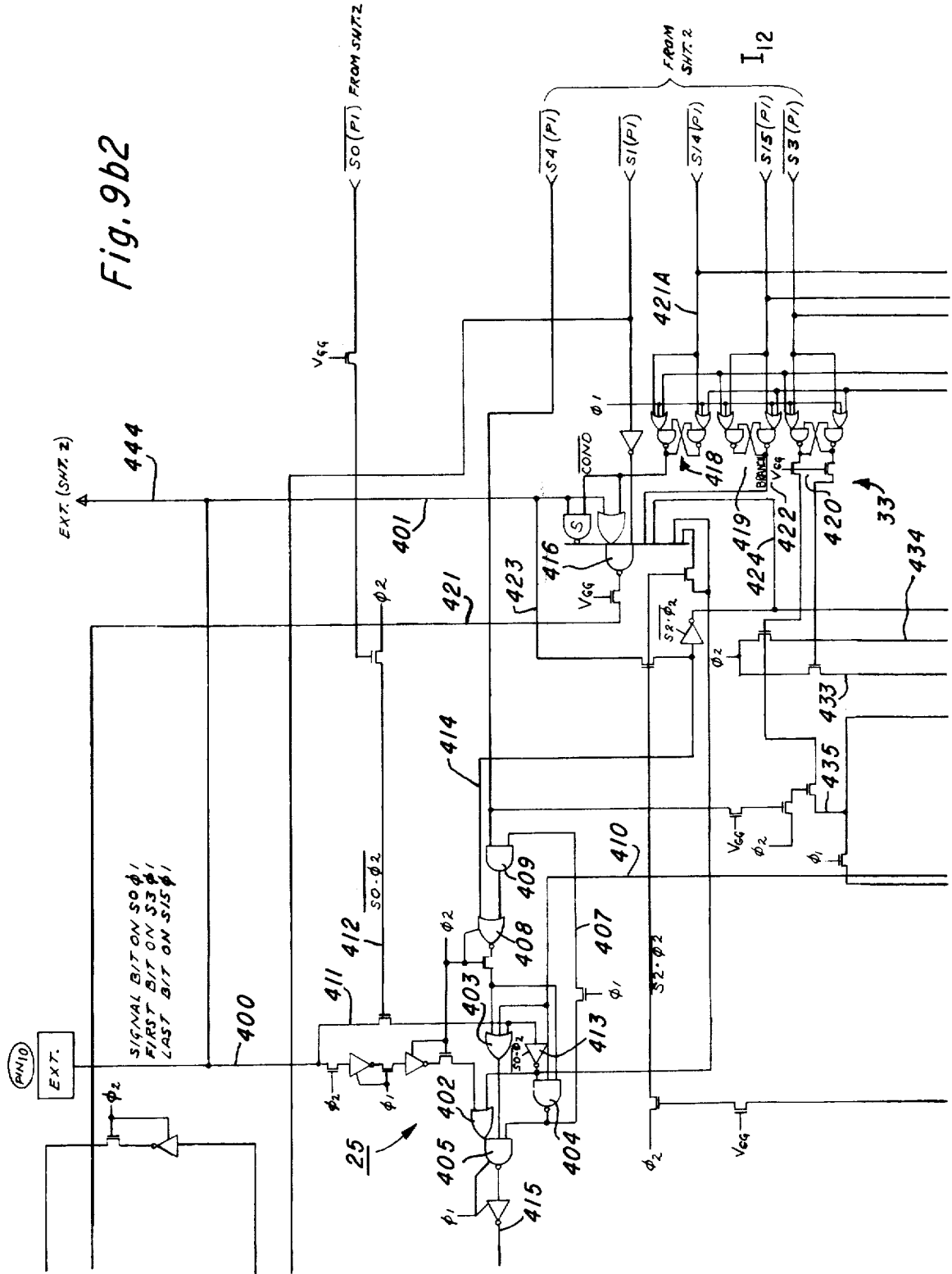

Fig. 9b1

Fig. 9b2



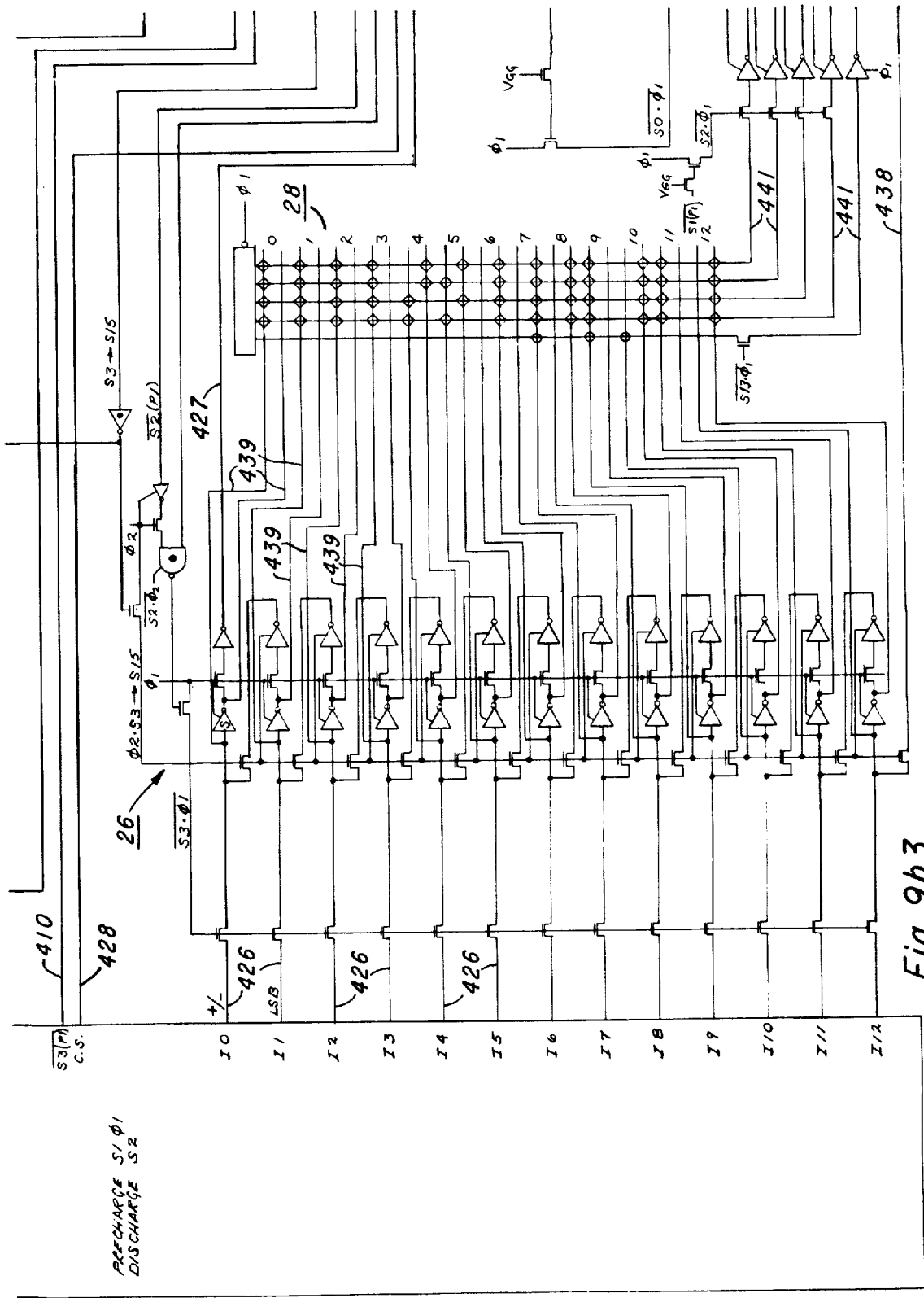

Fig. 9b3

PRECHARGE S1 phi1
DISCHARGE S2

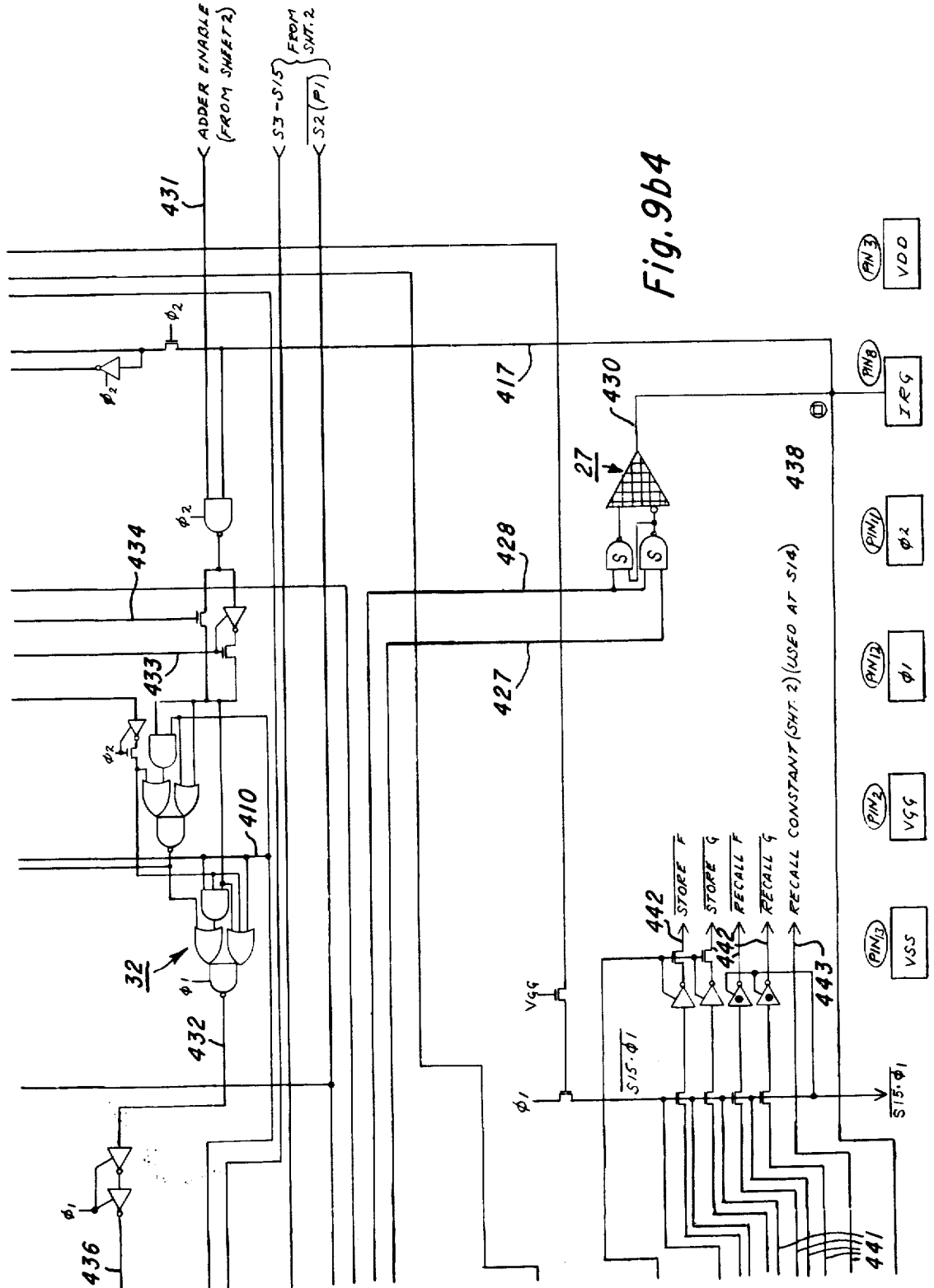

Fig. 9c1

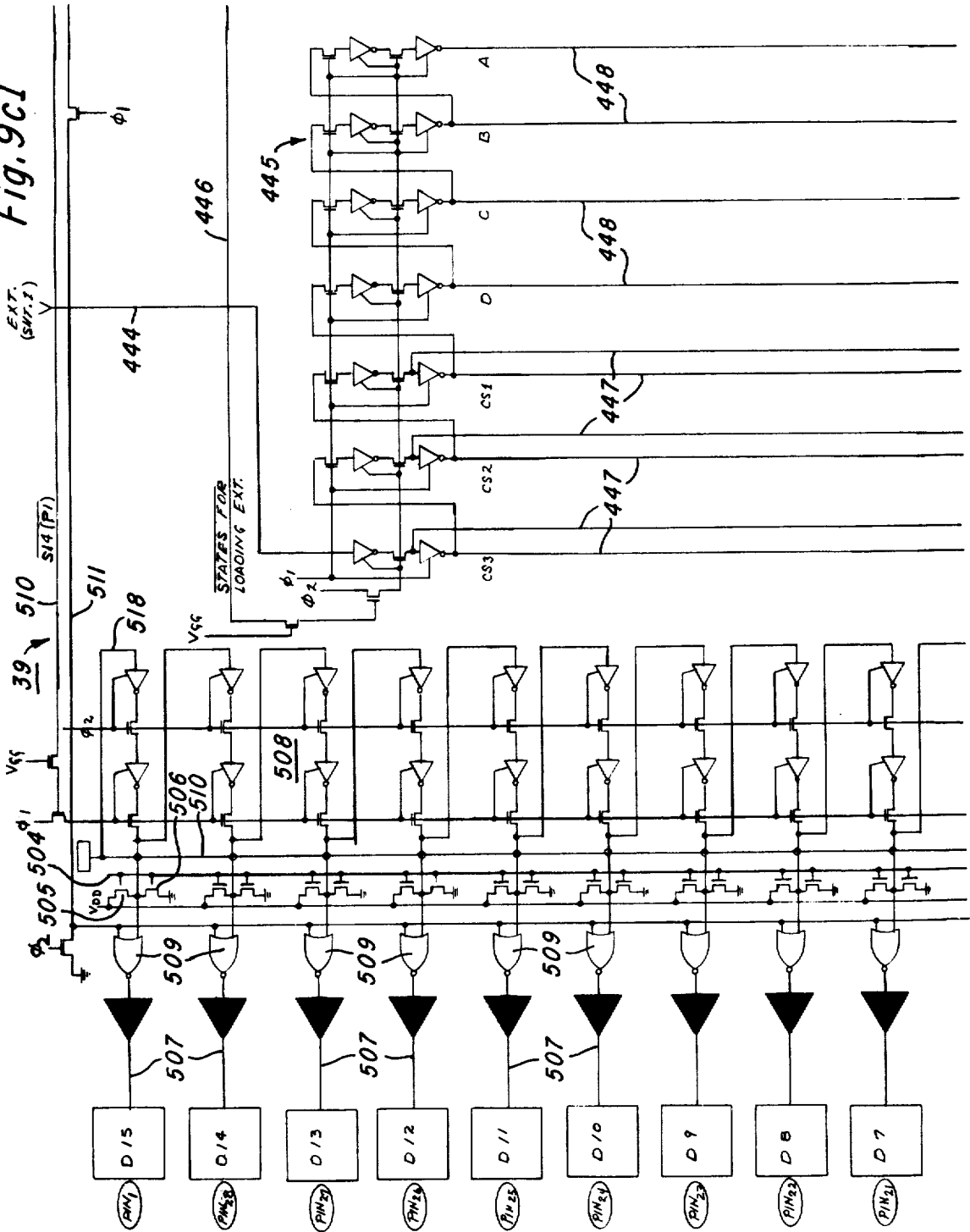
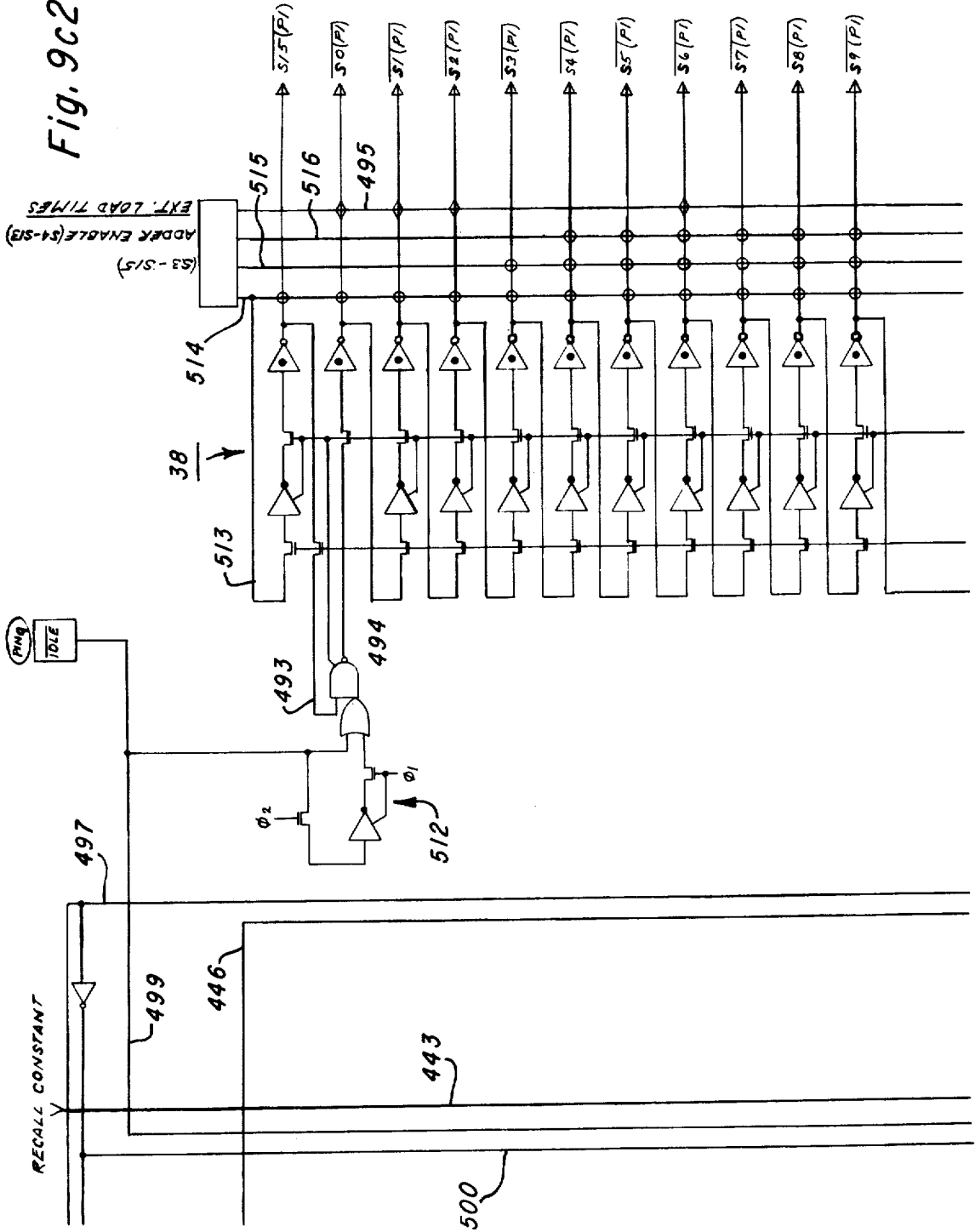

Fig. 9c2



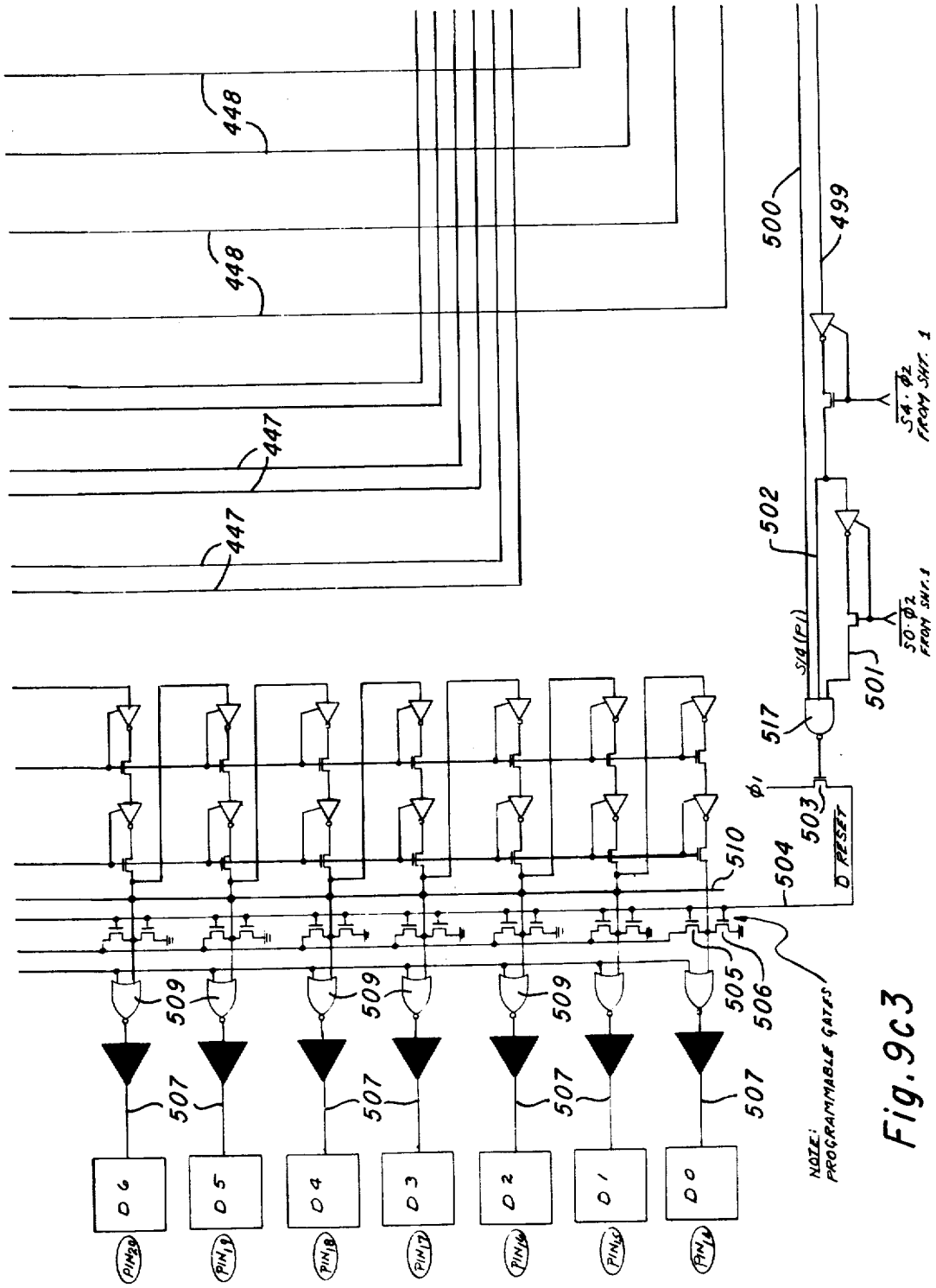

Fig. 9c3

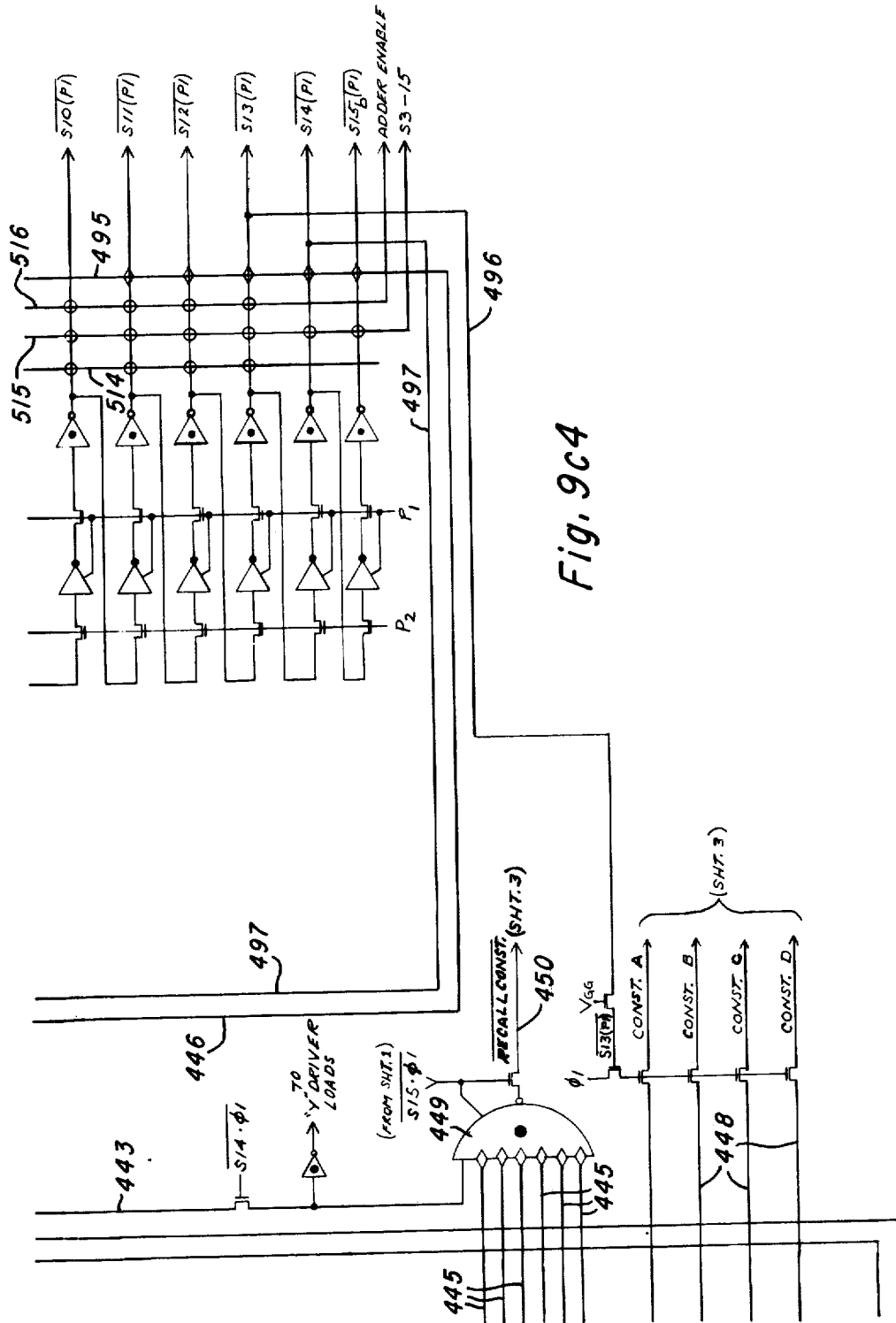

Fig. 9c4

Fig. 8d1

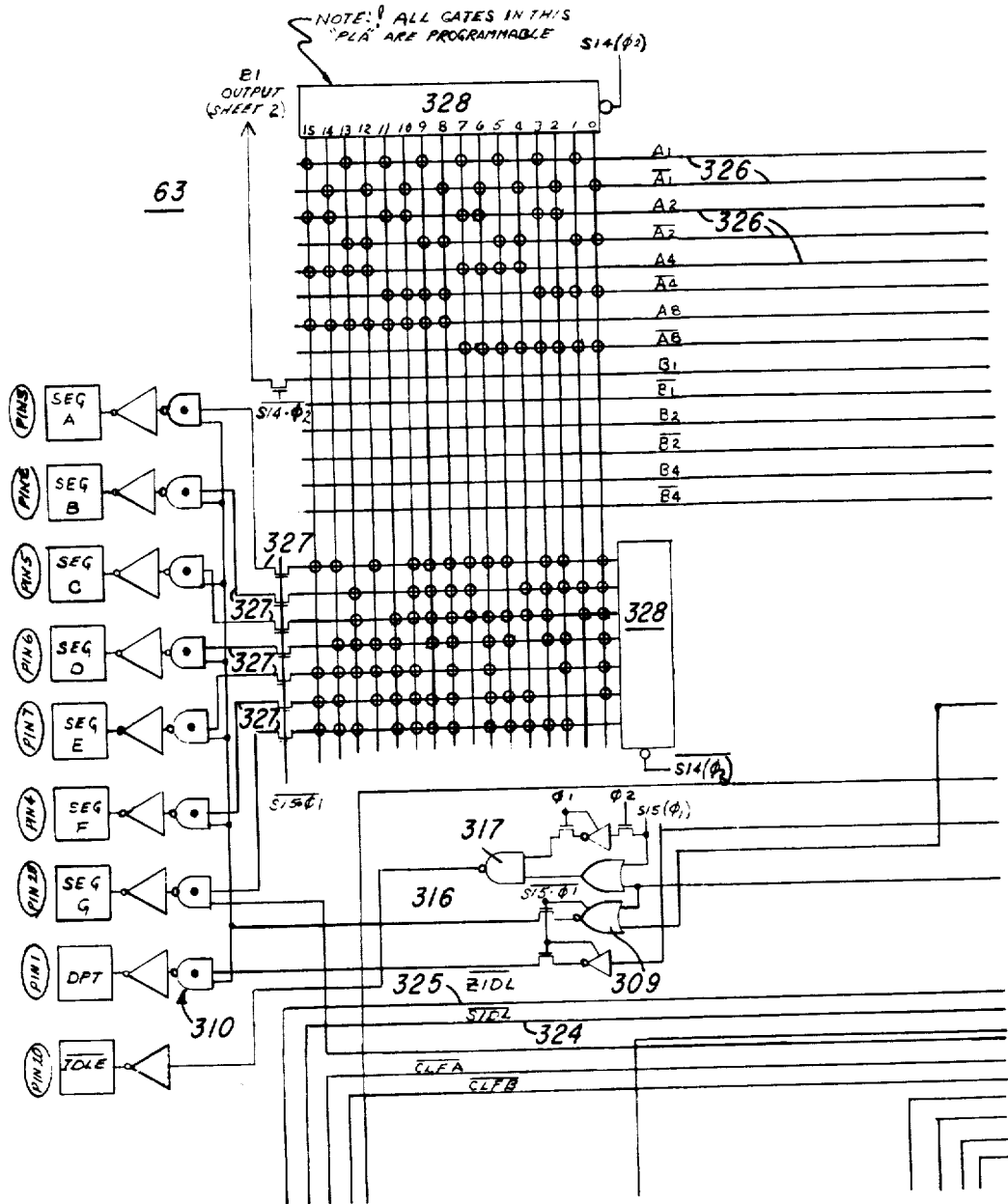
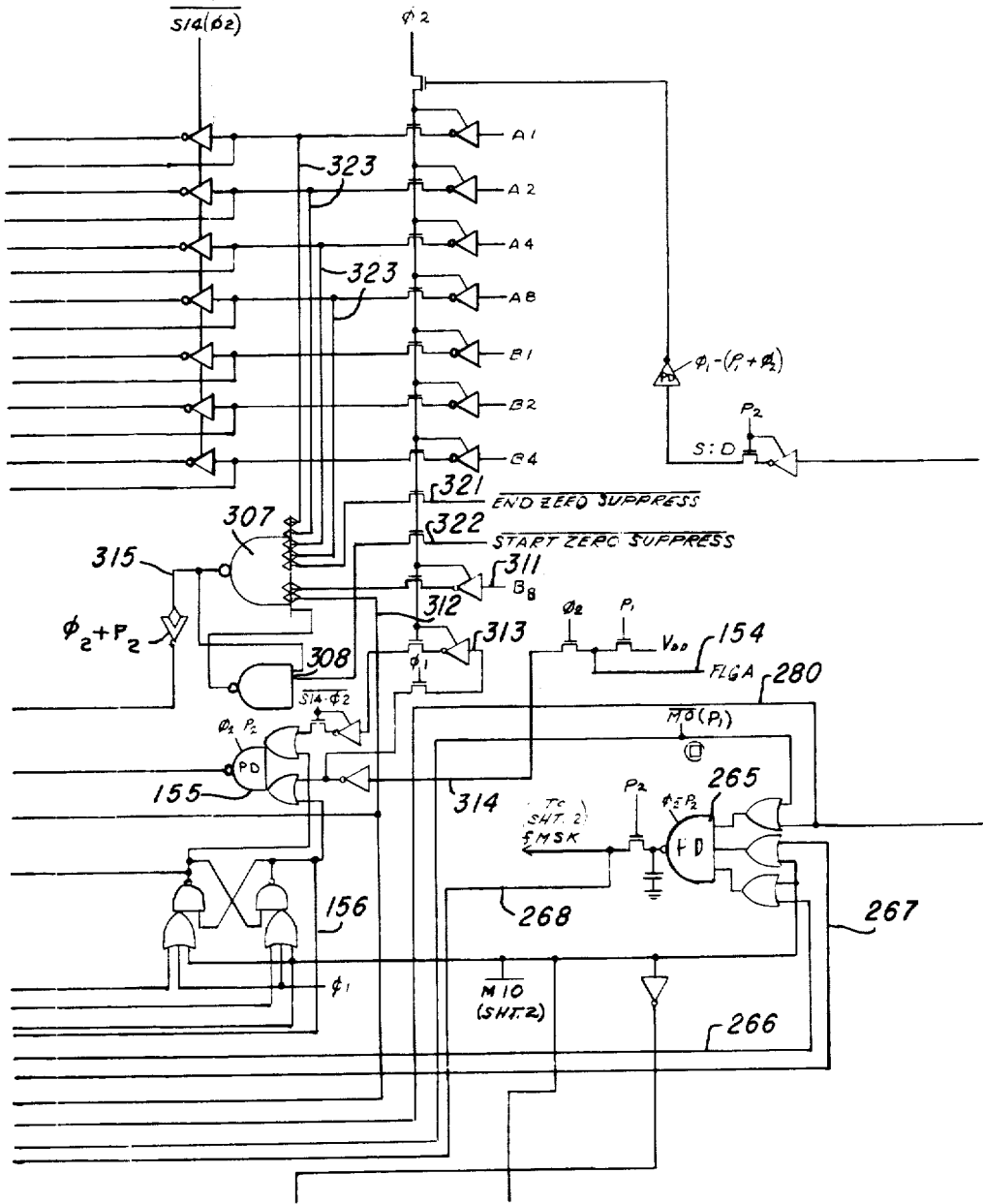

Fig. 8d2



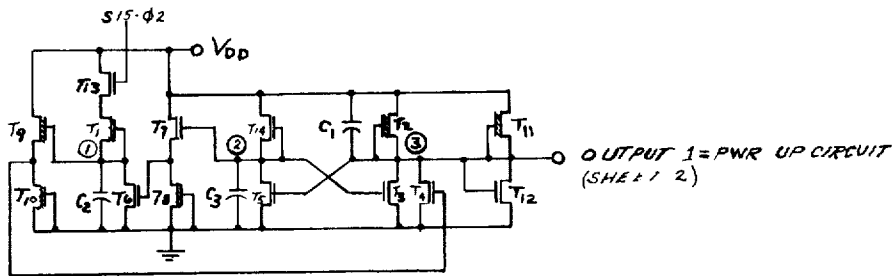

Fig. 8d3

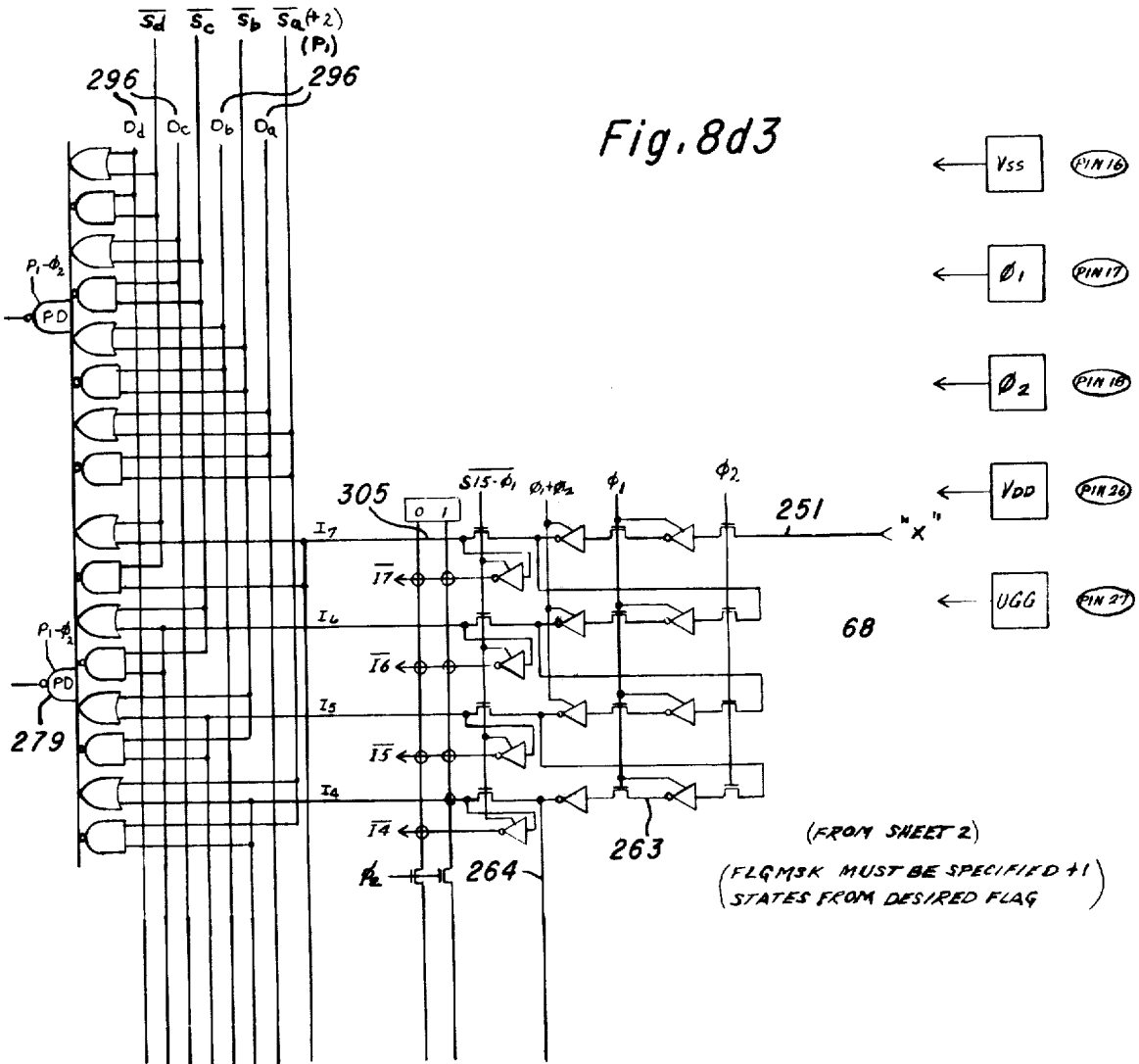

Fig. 8d4

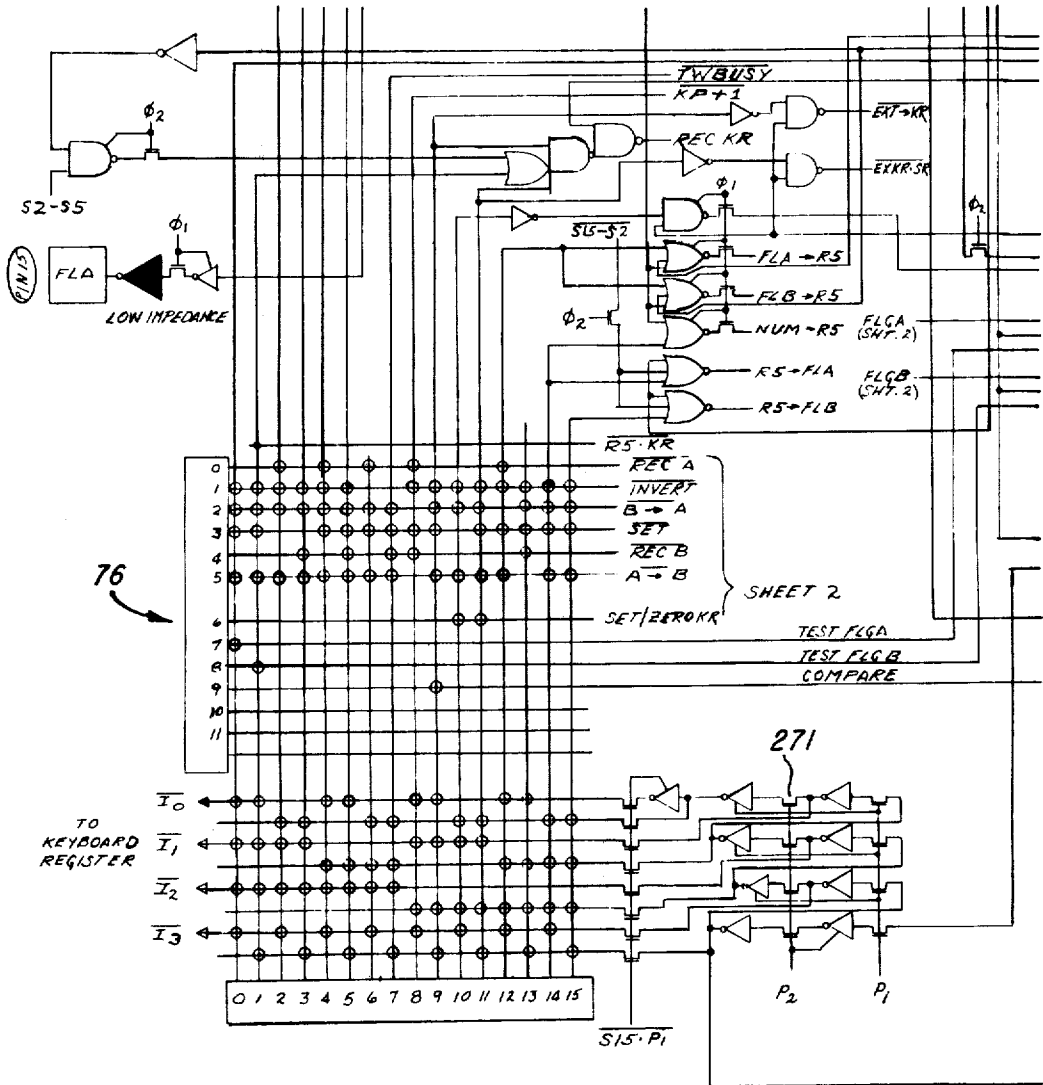

Fig. 8d5

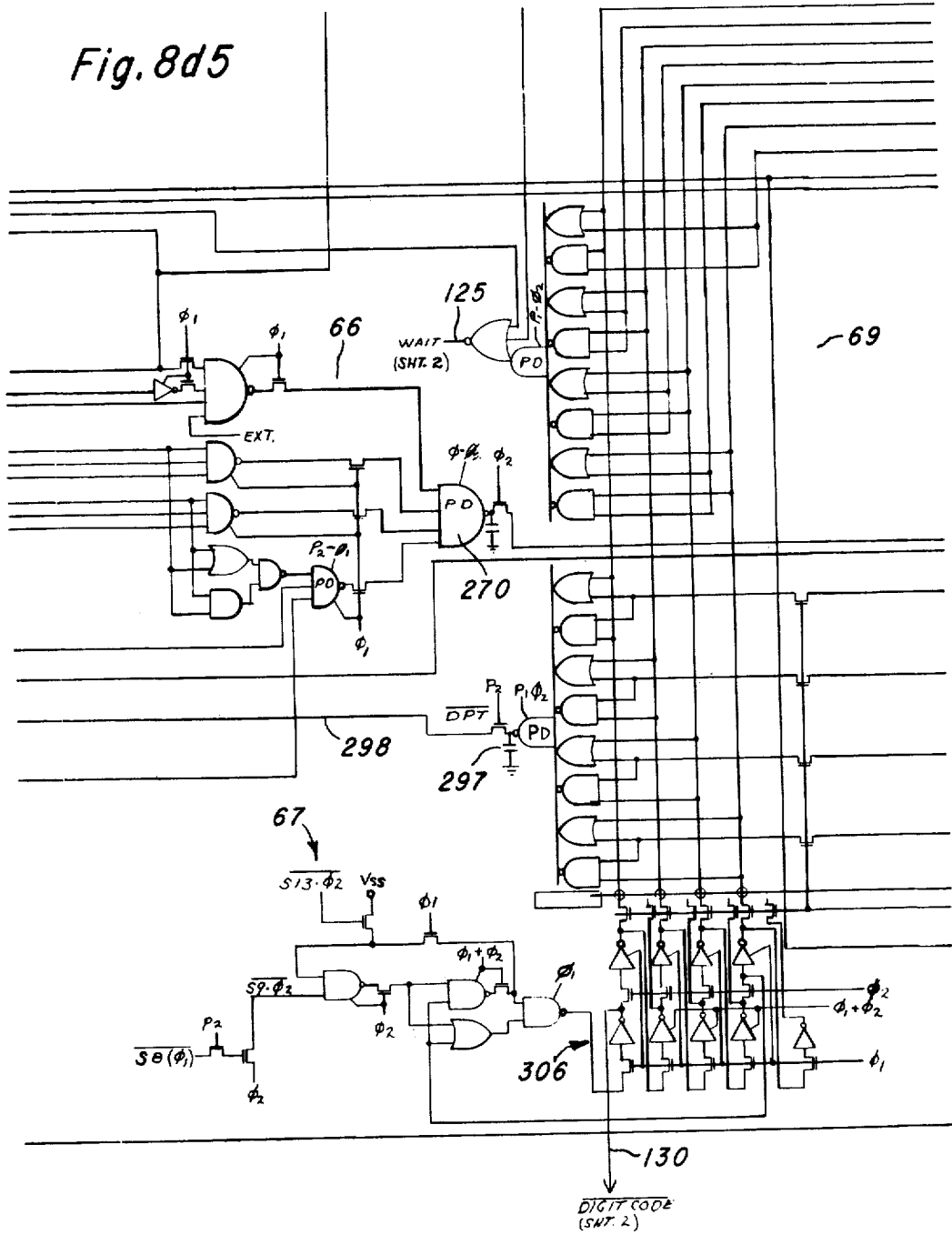
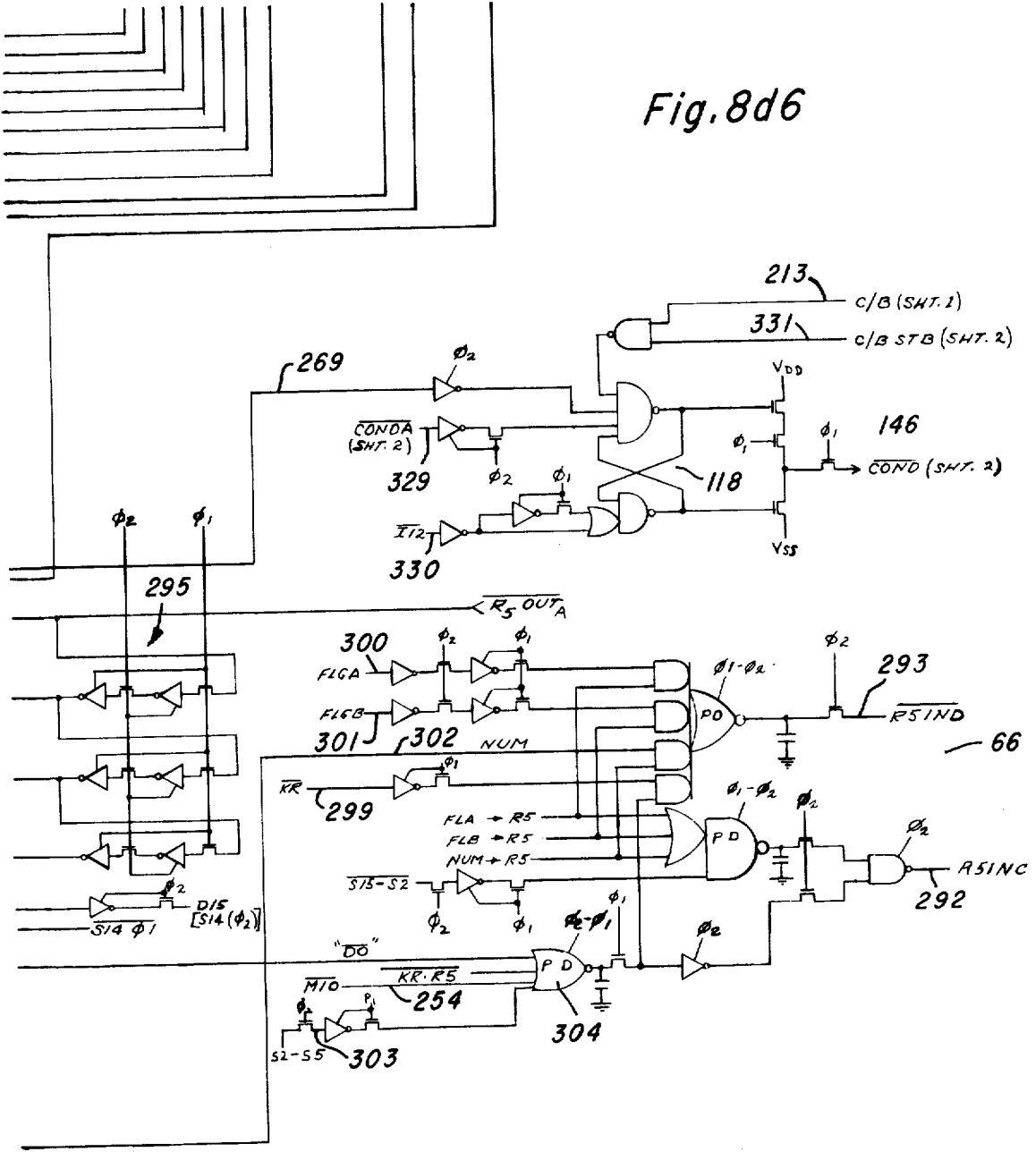

Fig. 8d6



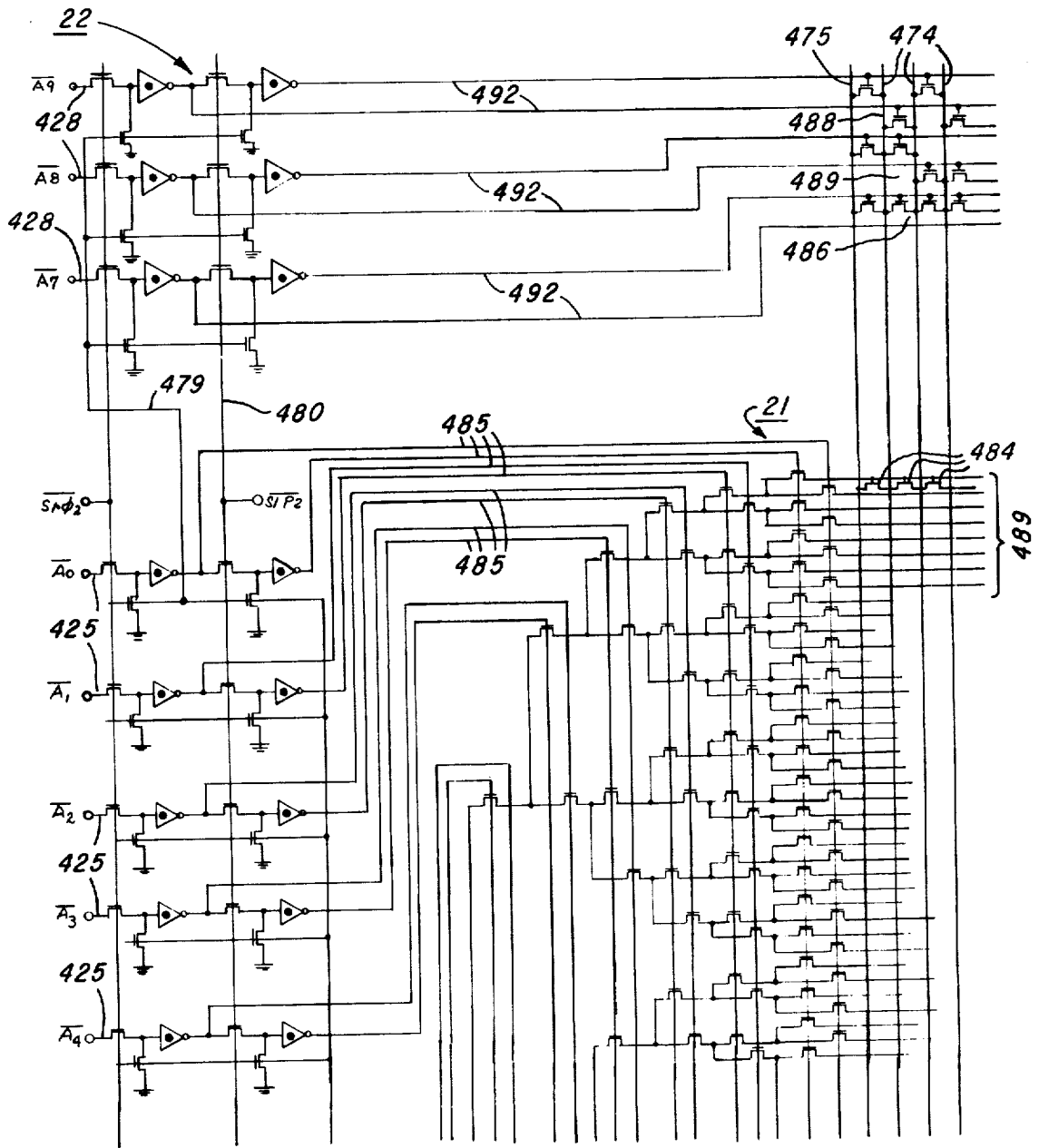

Fig. 9d1

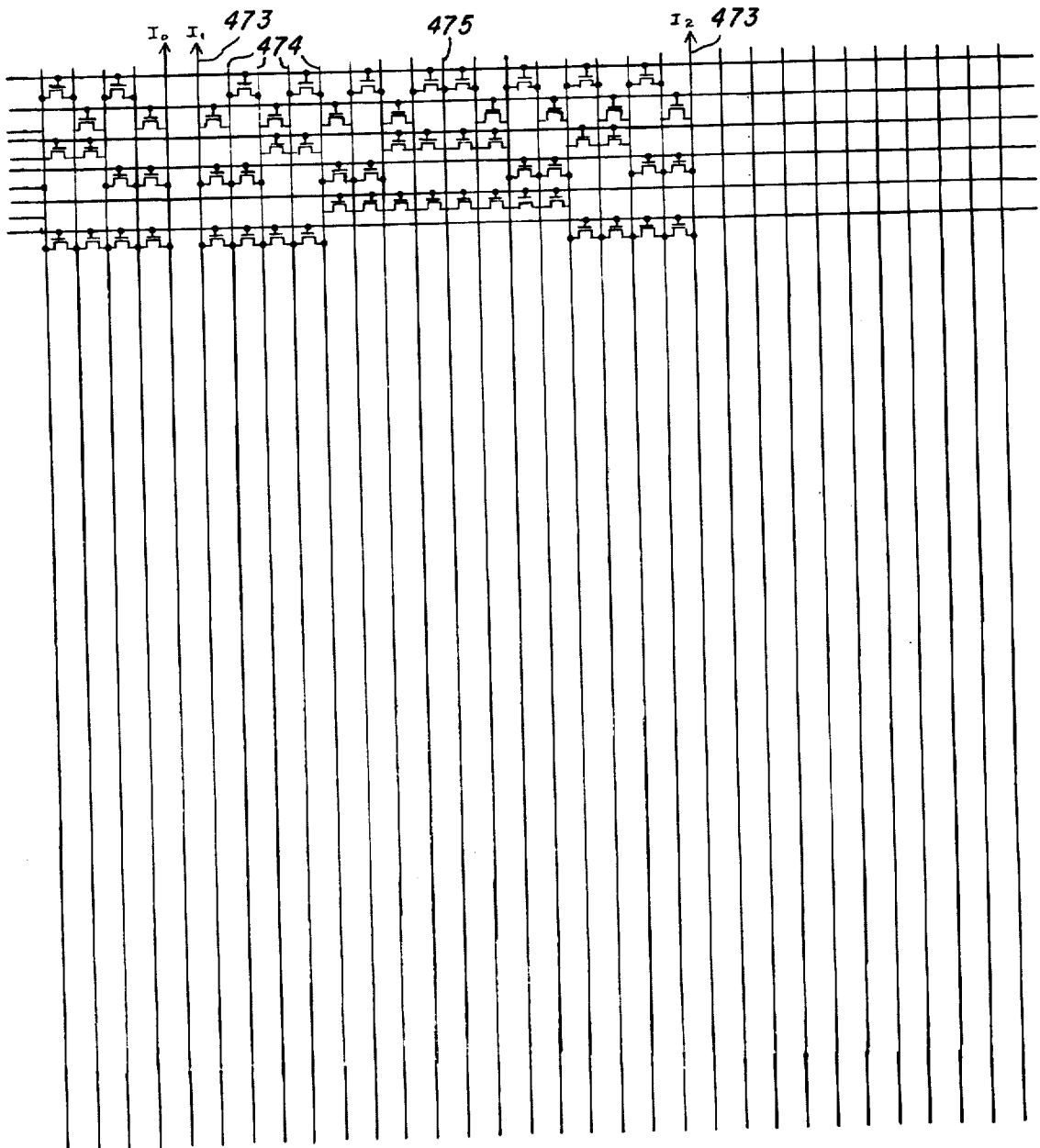

Fig. 9d2

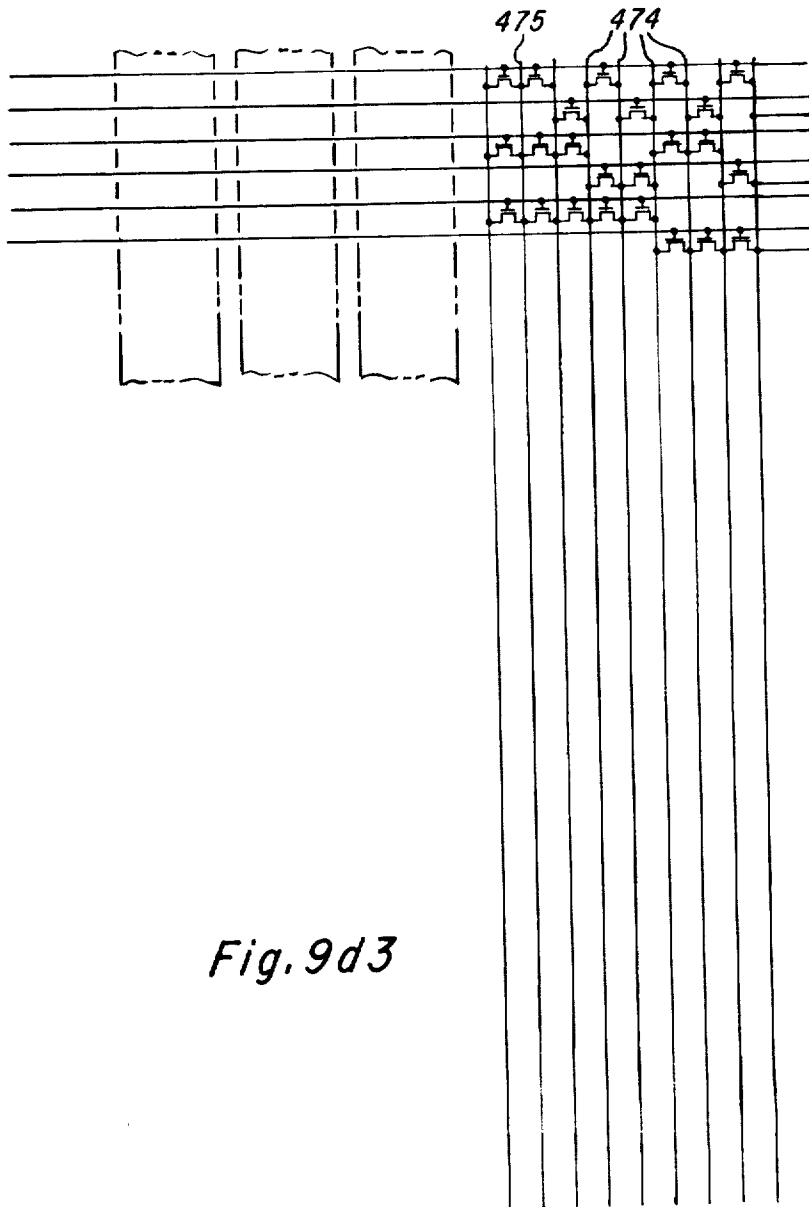

Fig. 9d3

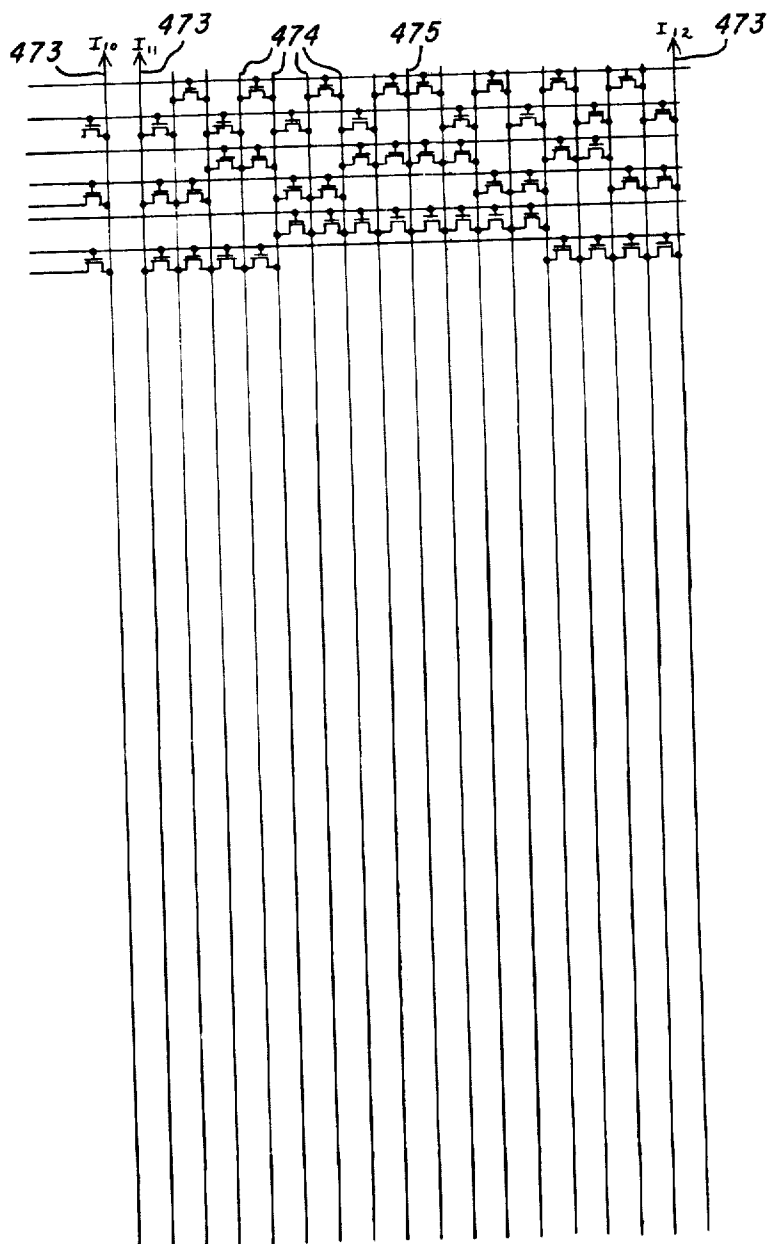

Fig. 9d4

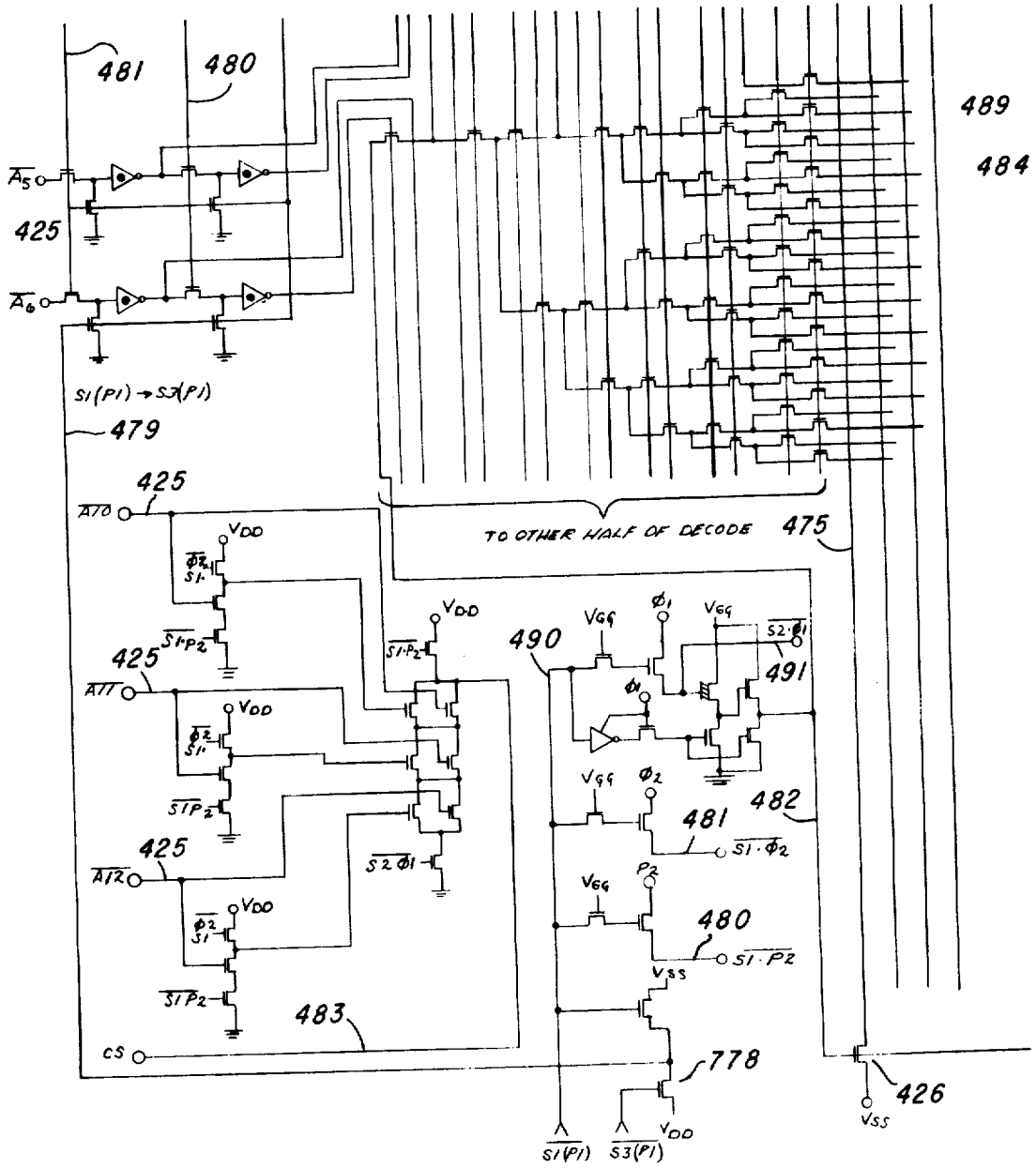

Fig. 9d5

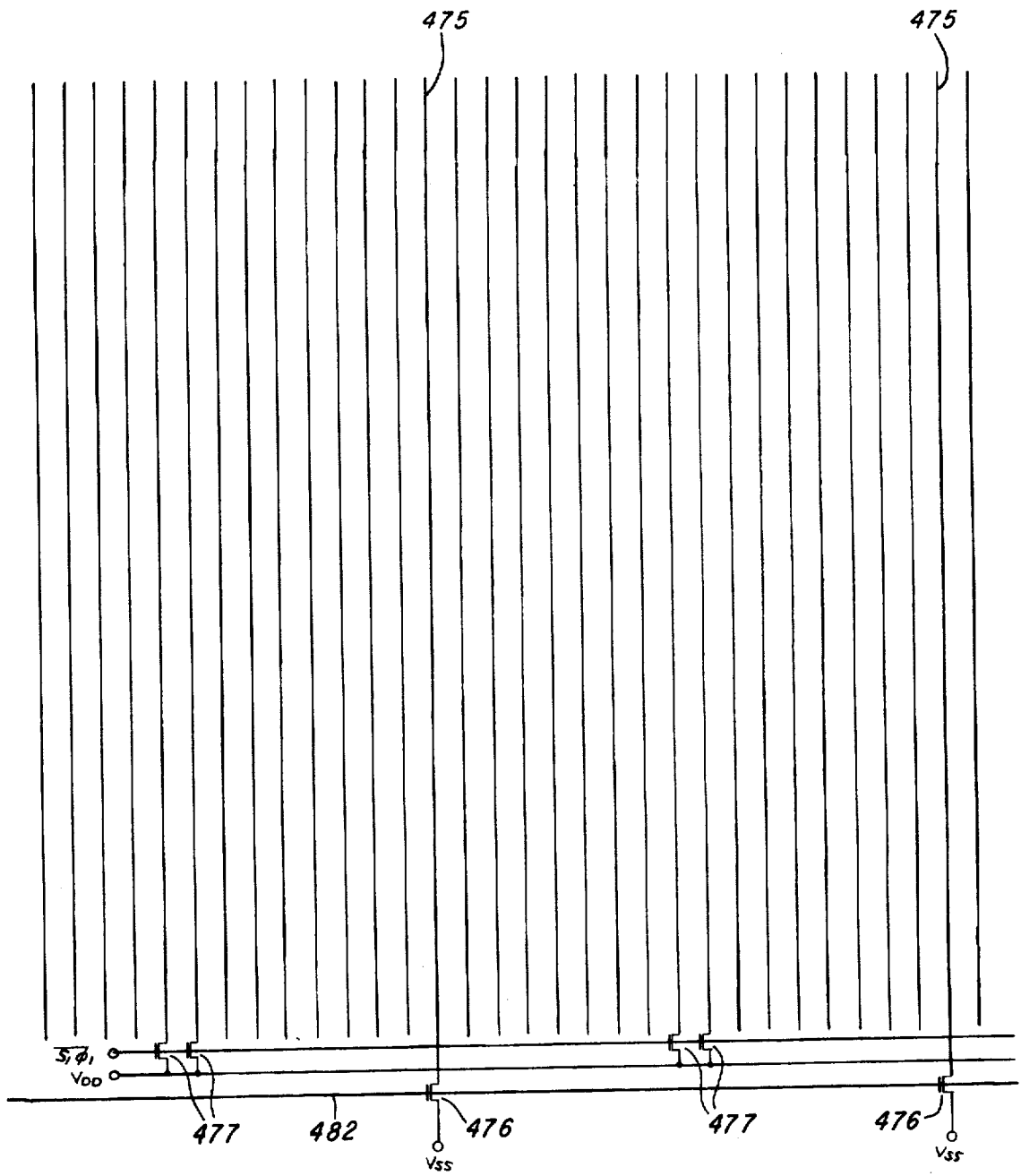

Fig. 9d6

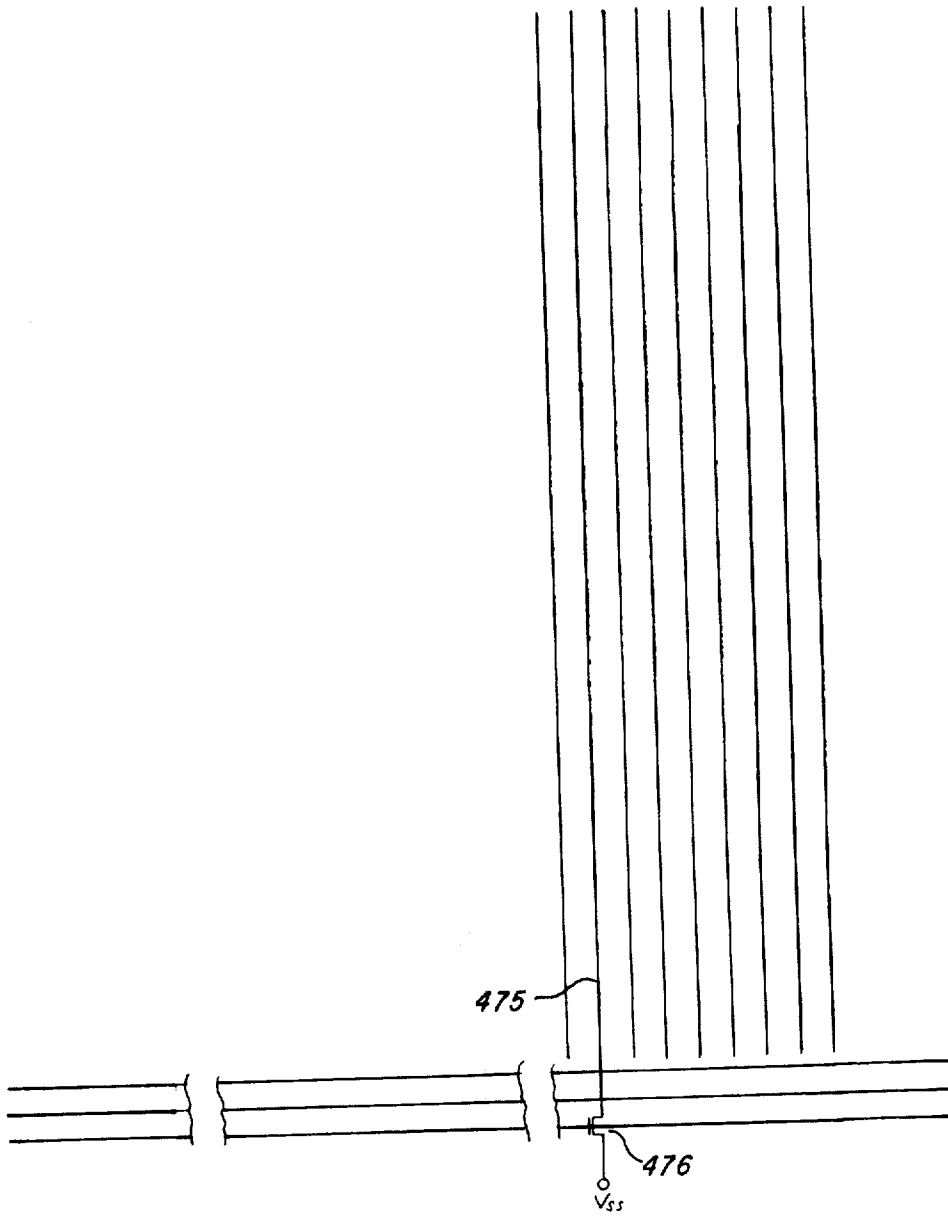

Fig. 9d7

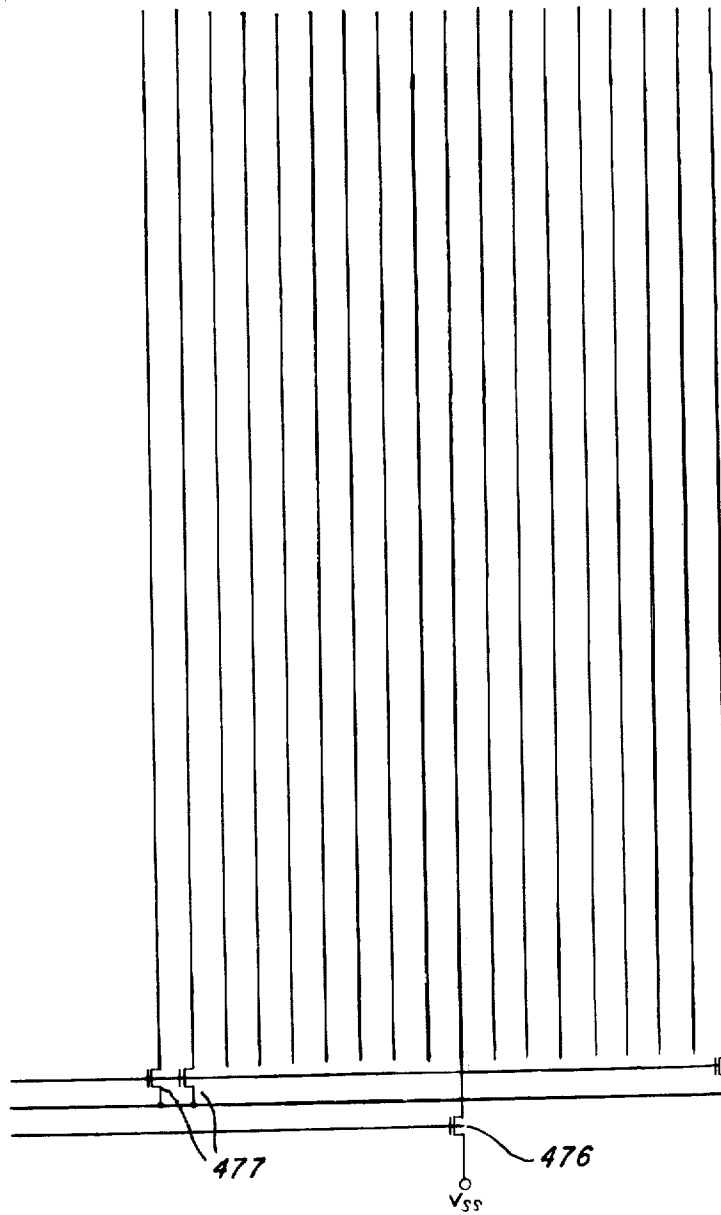

Fig. 9d8

Fig. 9e1

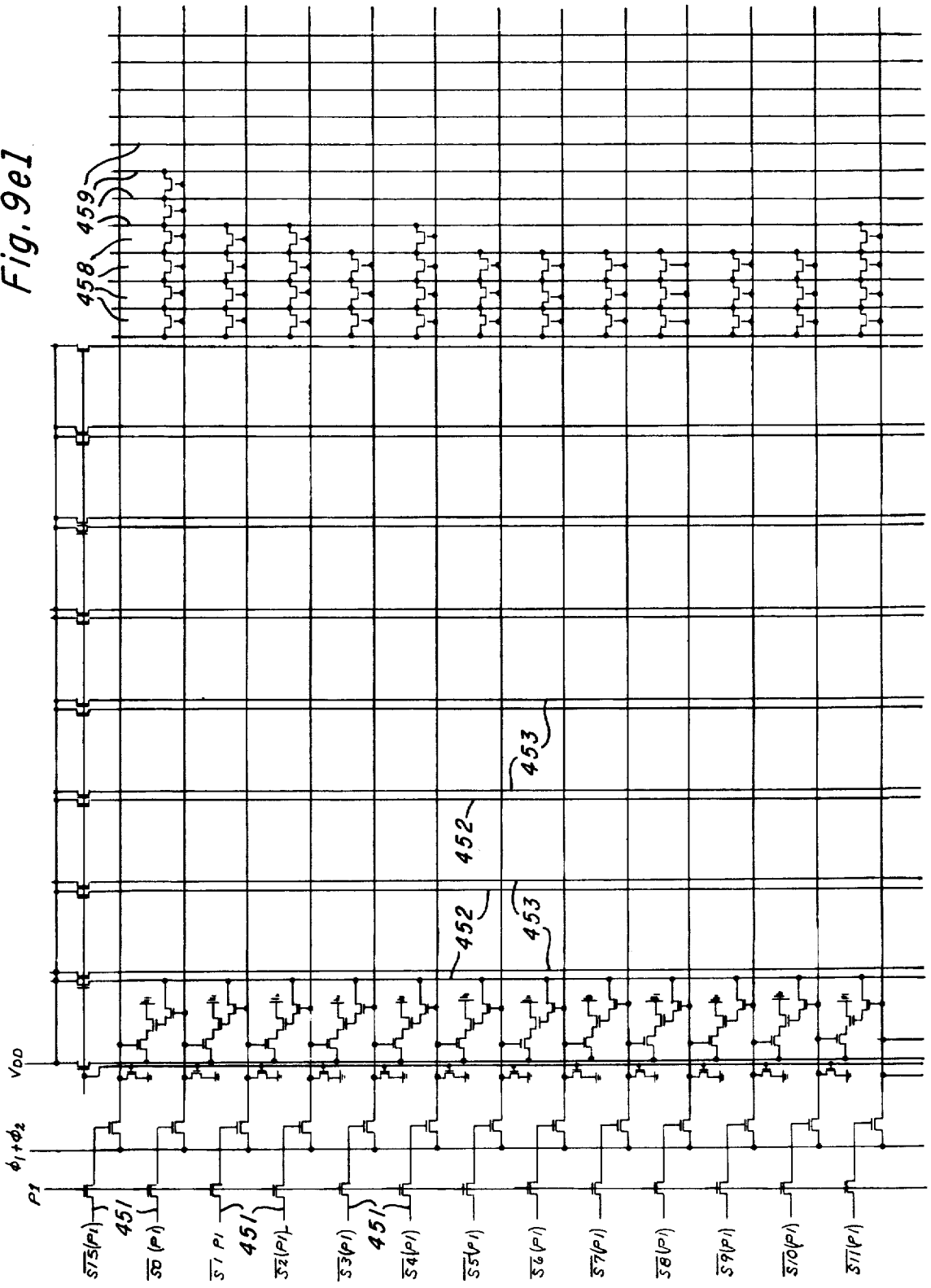

Fig. 9e2

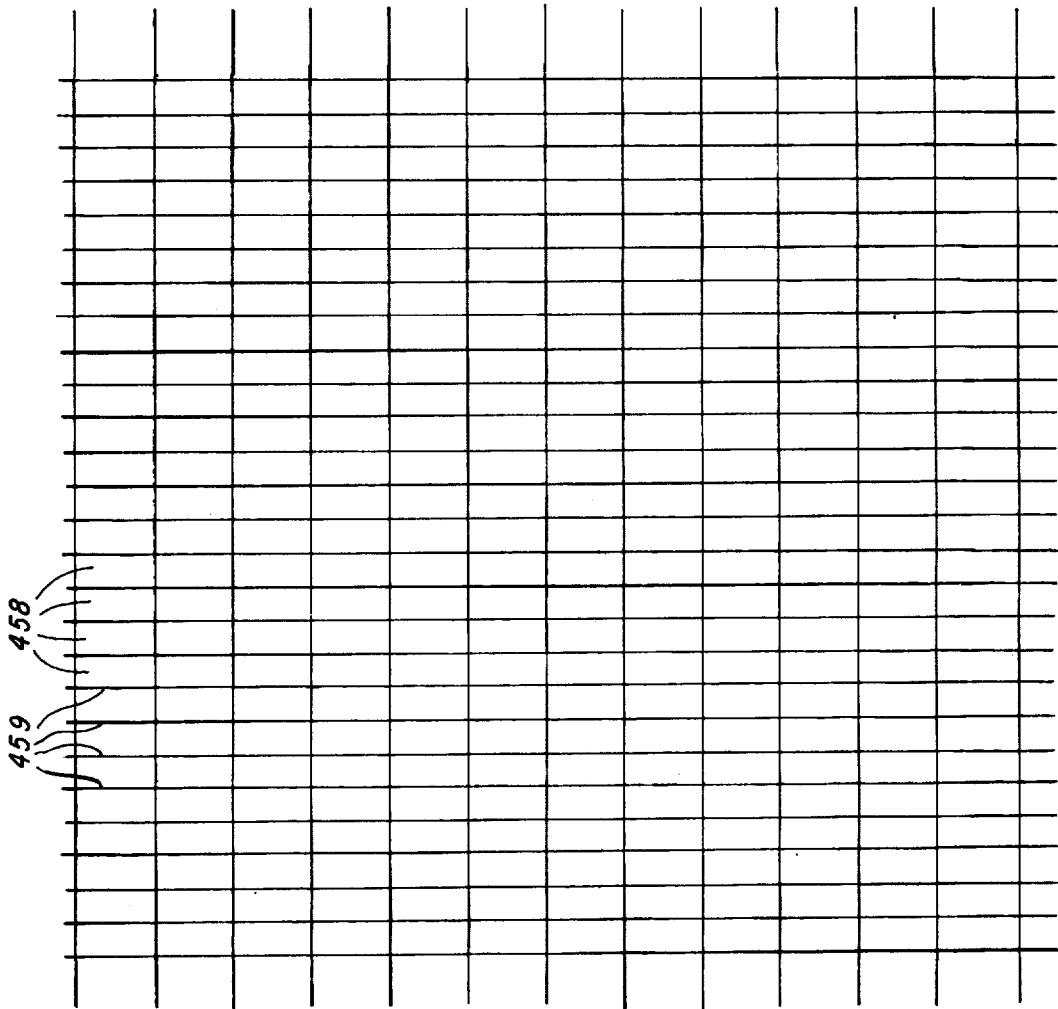
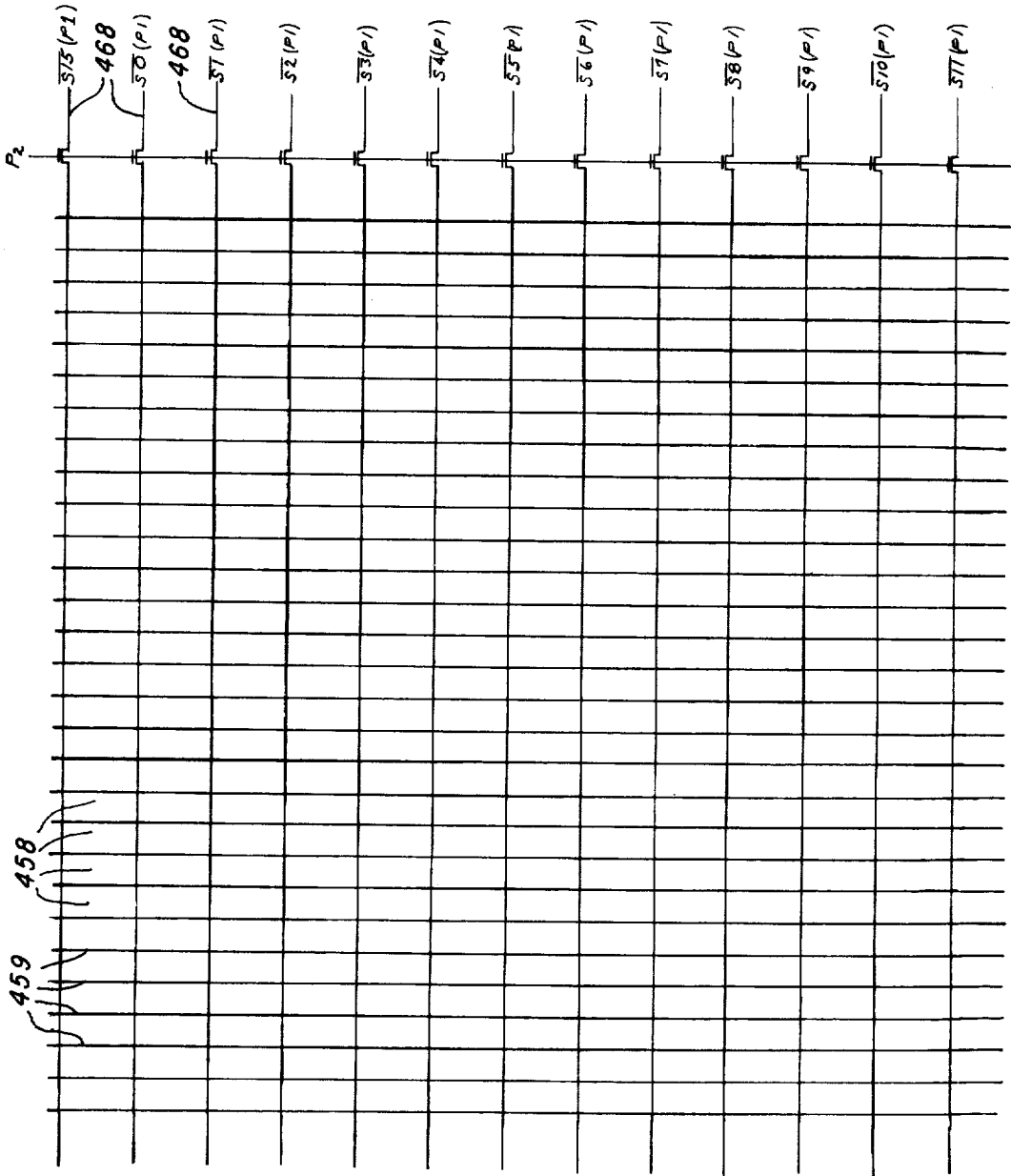

Fig. 9e3



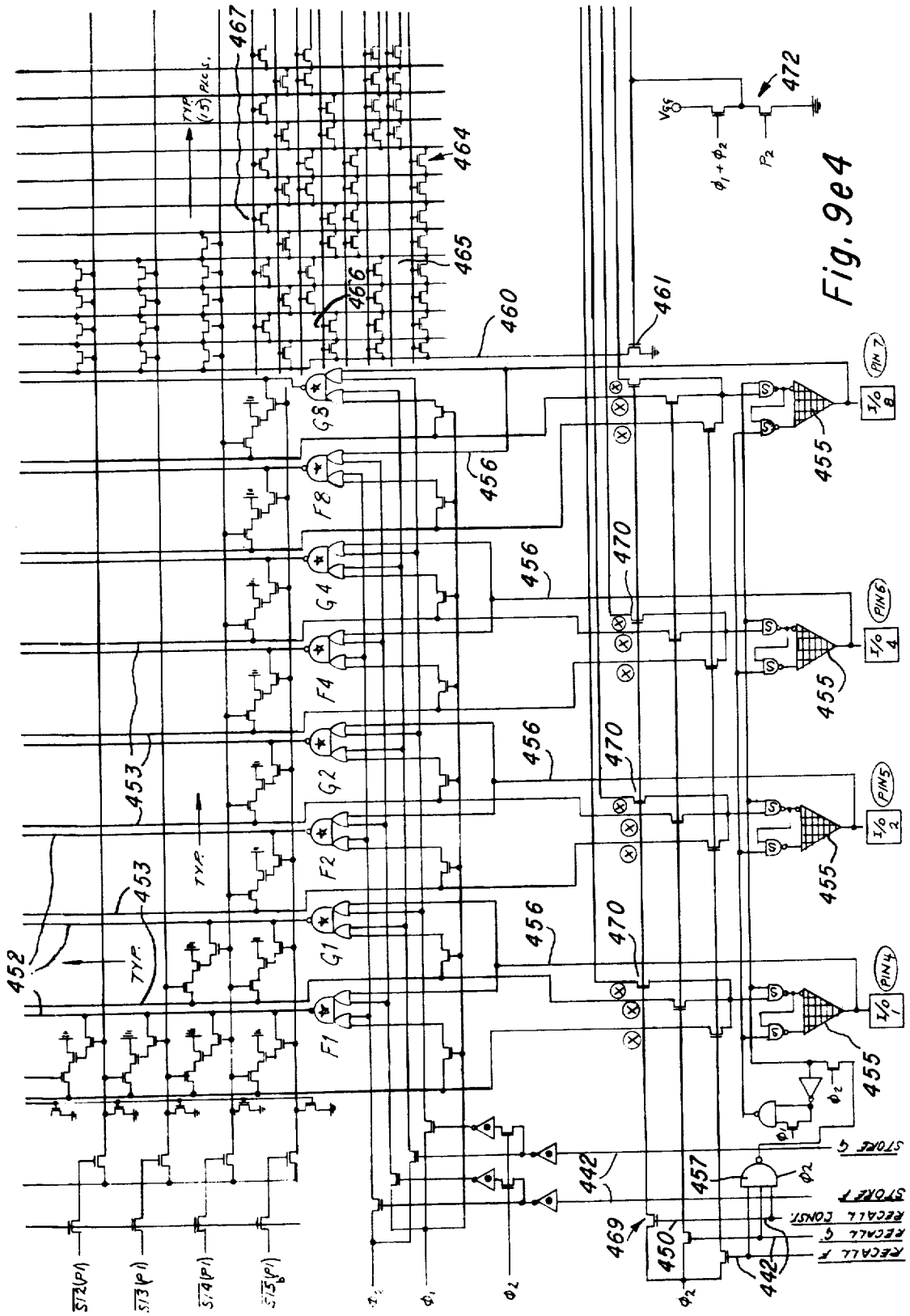

Fig. 9e4

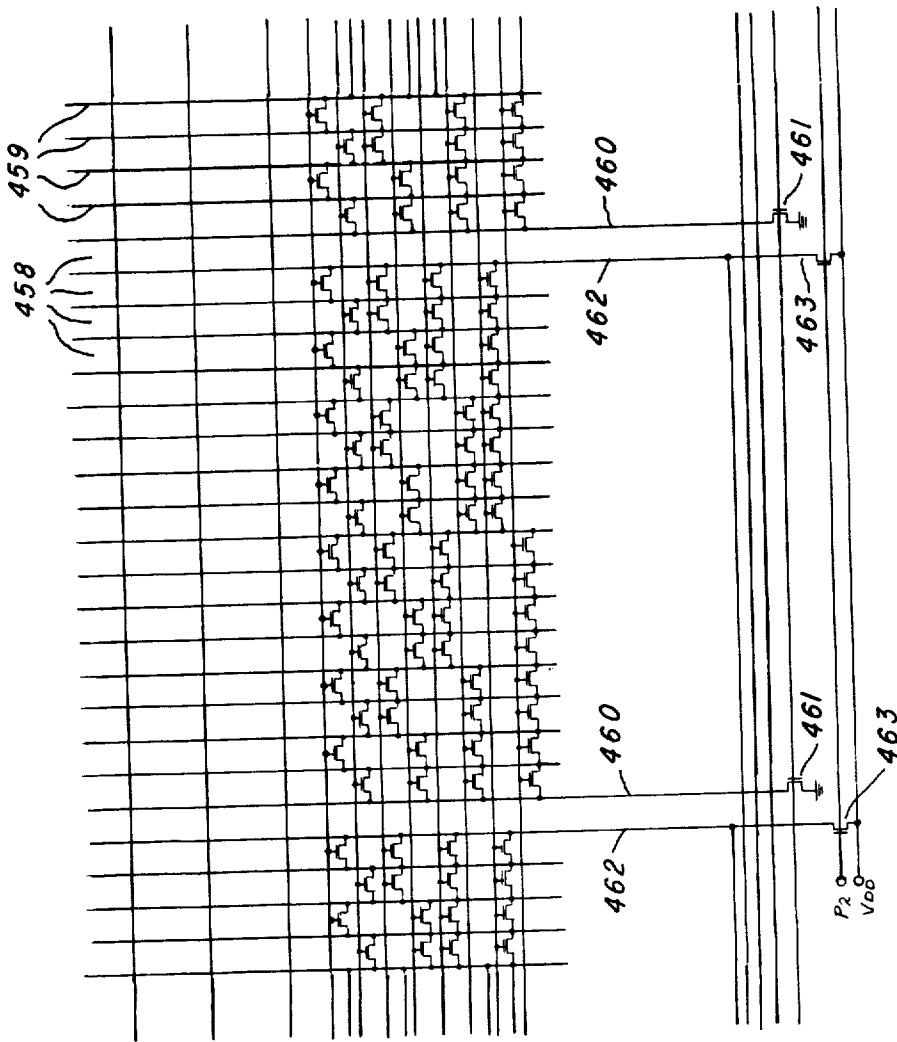

Fig. 9e5

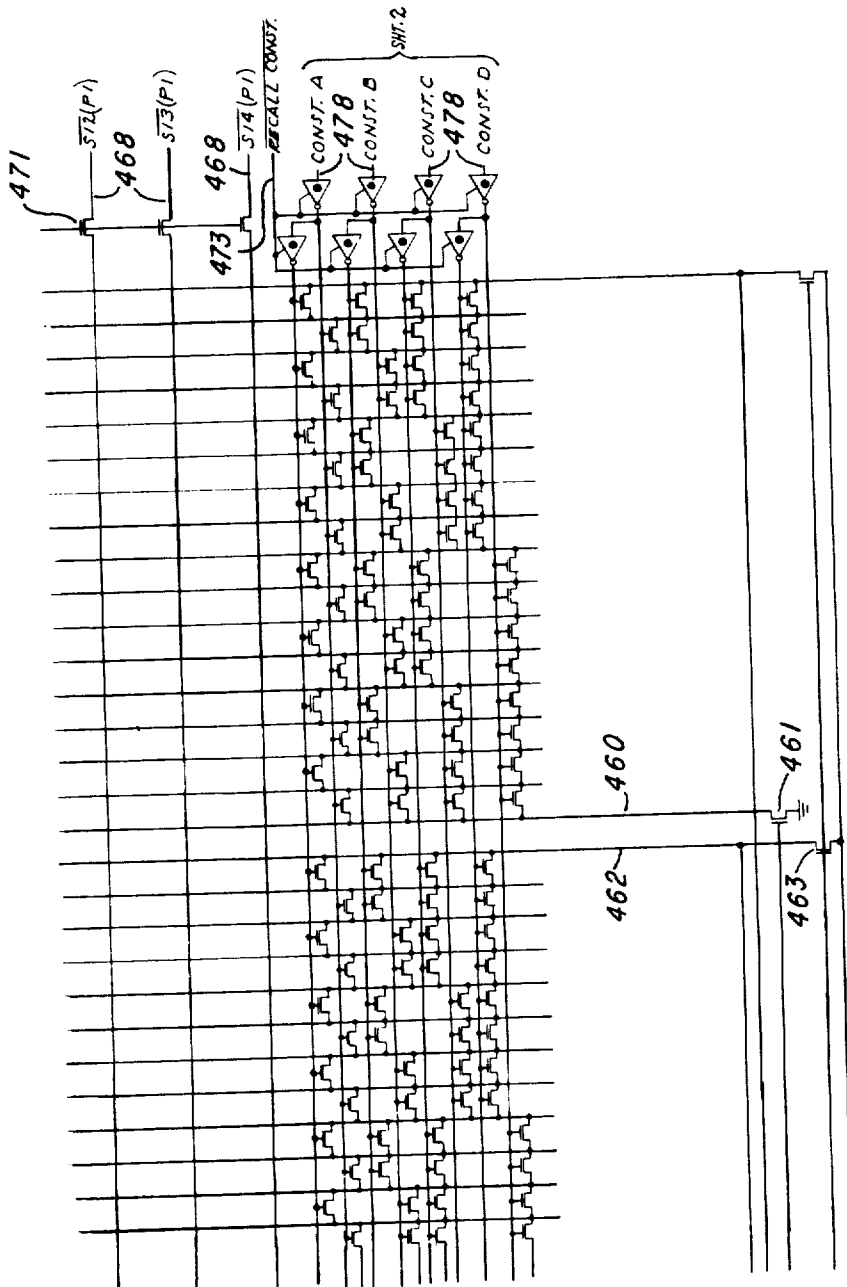
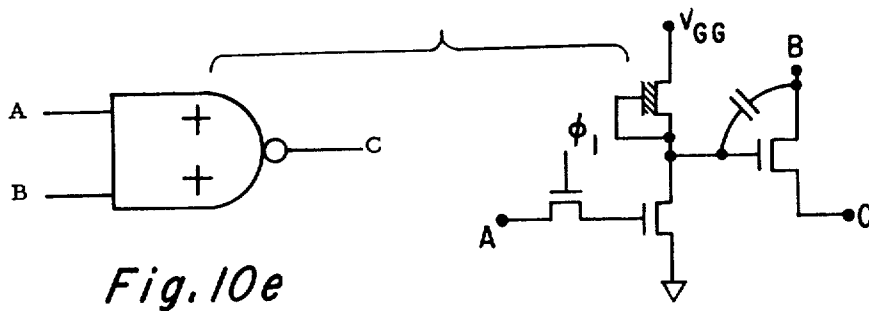
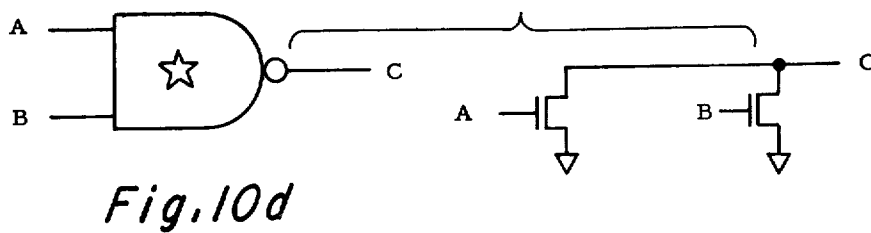
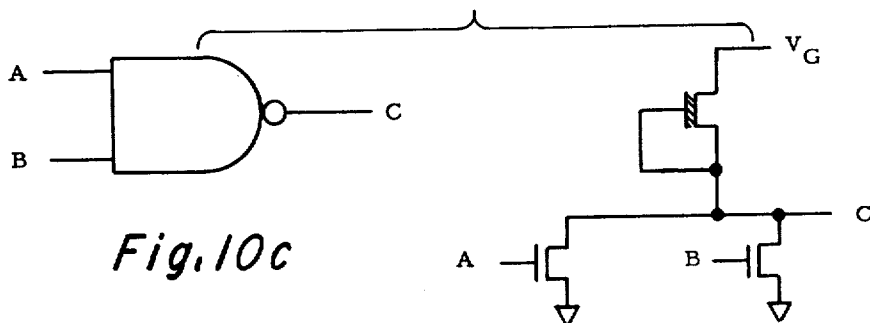
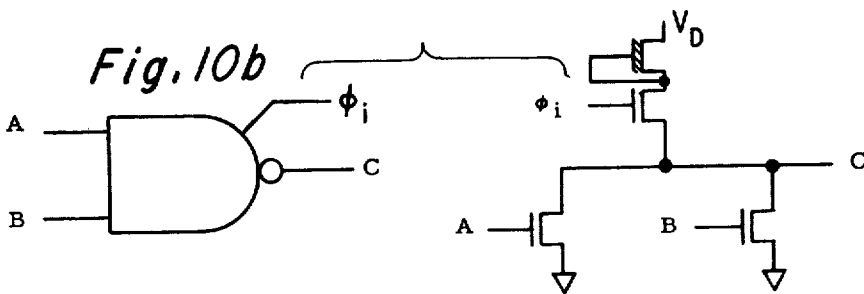
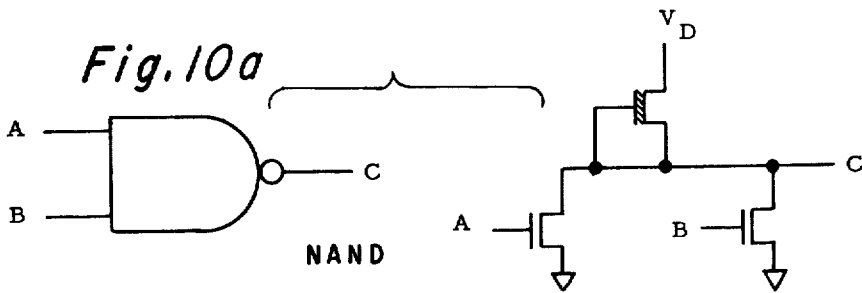

Fig. 9e6



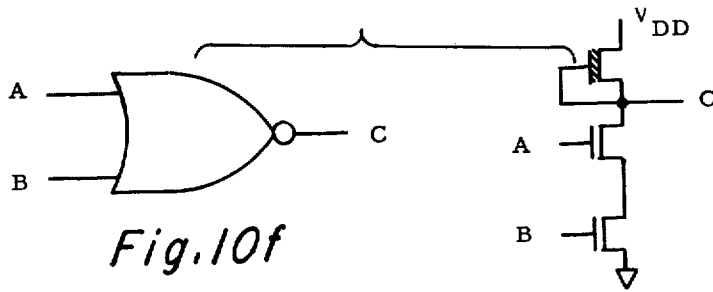

Fig. 10f

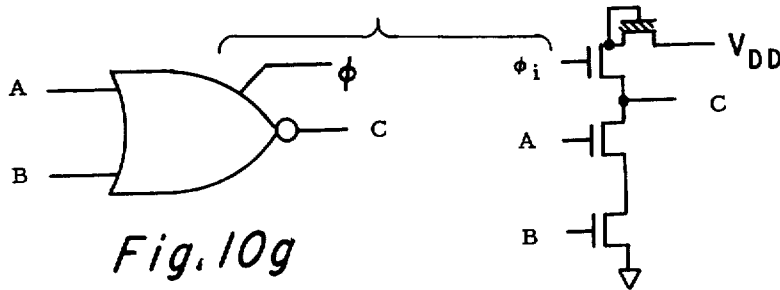

Fig. 10g

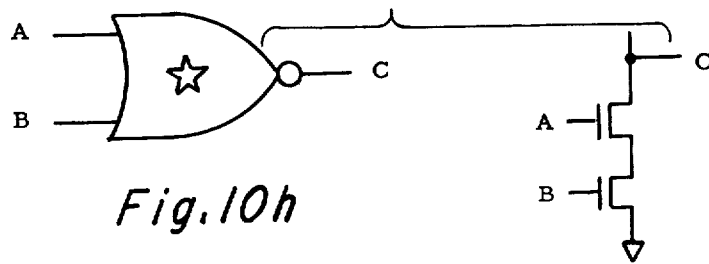

Fig. 10h

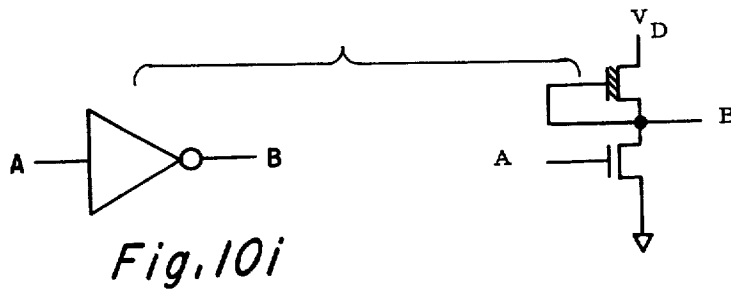

Fig. 10i

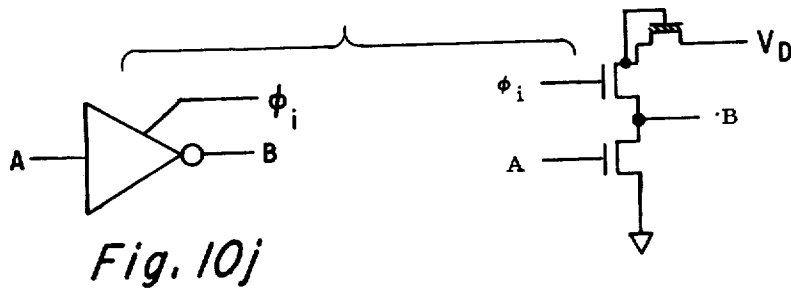
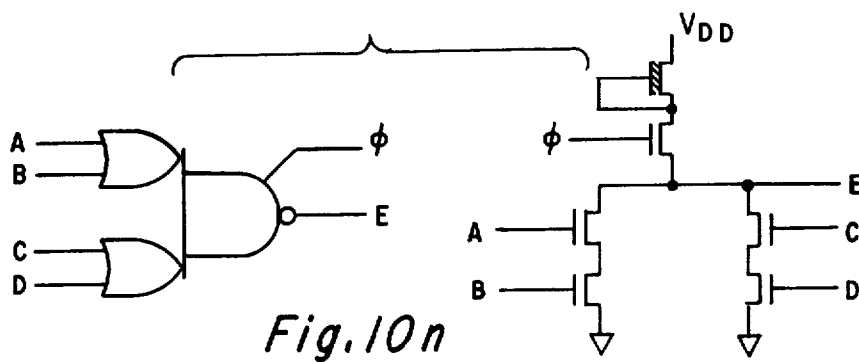
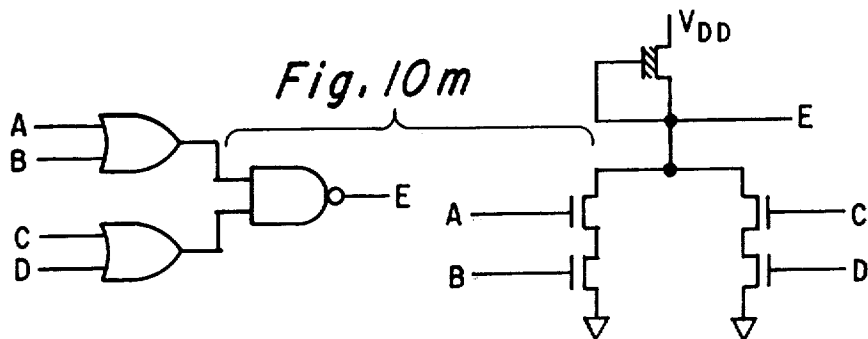
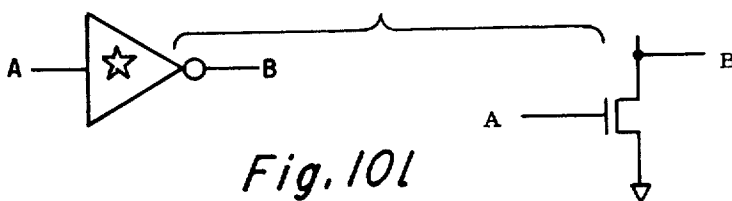
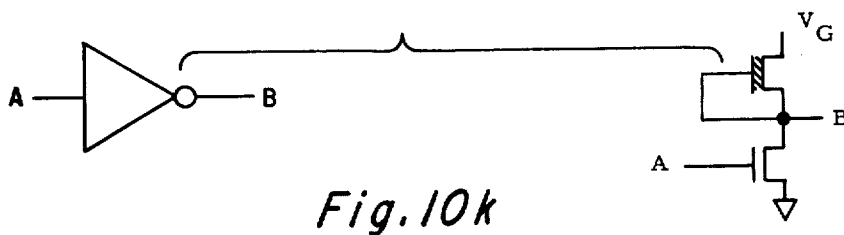
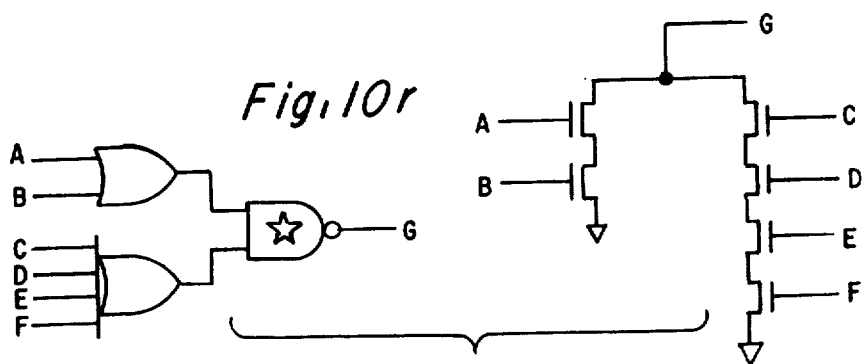
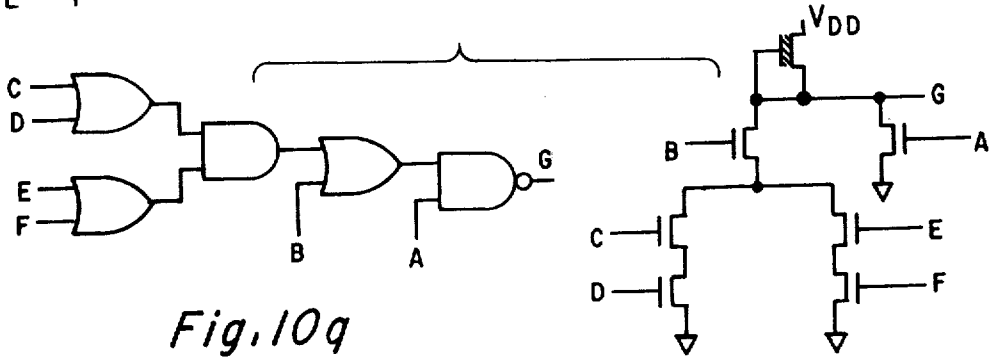
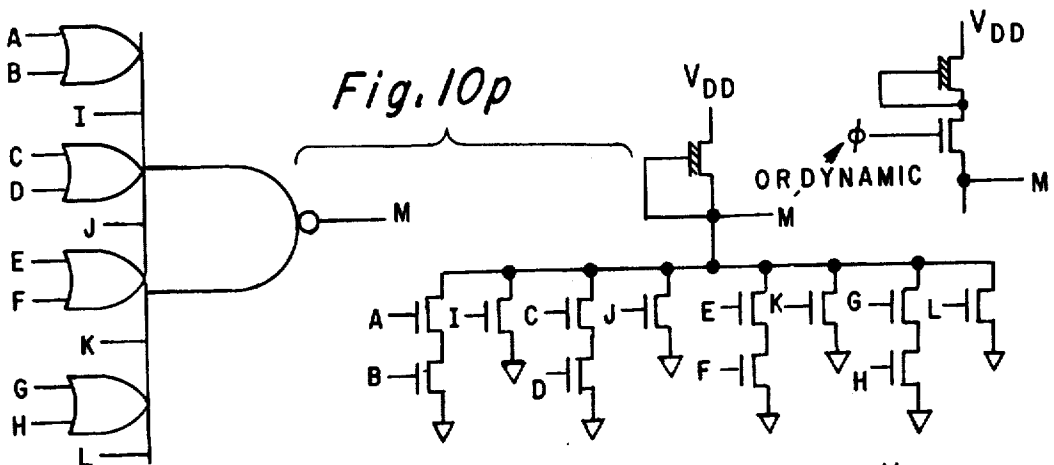
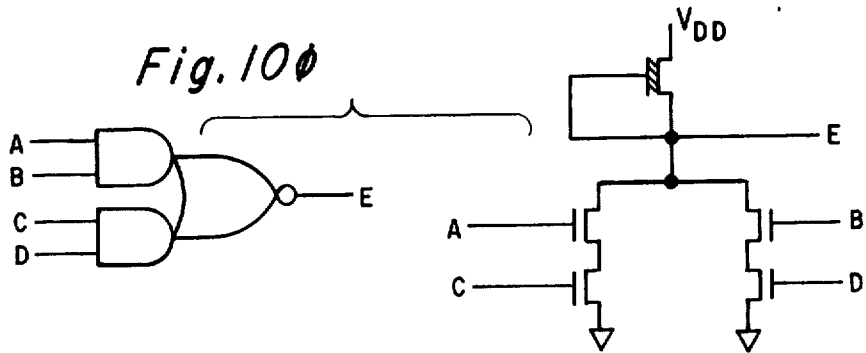

Fig. 10j





MULTI-CHIP CALCULATOR SYSTEM HAVING CYCLE AND SUBCYCLE TIMING GENERATORS

Related subject matter is found in the following copending patent applications filed concurrently herewith:

- S/N 346,392, filed Mar. 30, 1973 TI-5190 — CALCULATOR SYSTEM FEATURING RELATIVE PROGRAM MEMORY ADDRESSING
- S/N 396,902, filed Sept. 13, 1973 TI-5191 — CALCULATOR SYSTEM FEATURING A SUBROUTINE REGISTER
- S/N 397,056, filed Sept. 13, 1973 TI-5192 — CALCULATOR SYSTEM HAVING AN EXCHANGE DATA MEMORY REGISTER
- S/N 397,185, filed Sept. 13, 1973 — CALCULATOR SYSTEM HAVING PRECHARGED ARITHMETIC LOGIC UNIT
- S/N 397,048, filed Sept. 13, 1973 — CALCULATOR SYSTEM HAVING A CONSTANT MEMORY
- S/N 397,181, filed Sept. 13, 1973 TI-5195 — CALCULATOR SYSTEM HAVING KEYBOARD WITH DOUBLE ENTRY PROTECTION AND SERIALIZED ENCODING
- S/N 396,959, filed Sept. 13, 1973 TI-5196 — CALCULATOR SYSTEM HAVING A PRECHARGED VIRTUAL GROUND MEMORY
- S/N 396,901, filed Sept. 13, 1973 TI-5199 — CALCULATOR SYSTEM HAVING MULTI-FUNCTION MEMORY INSTRUCTION REGISTER
- S/N 397,465, filed Sept. 13, 1973 TI-5200 — CALCULATOR SYSTEM USING INSTRUCTION WORDS AS DATA
- S/N 397,054, filed Sept. 13, 1973 TI-5287 — CALCULATOR SYSTEM HAVING PLURALITY OF PROGRAM MEMORY ADDRESS REGISTERS

This invention relates to calculator systems in general and more specifically to addressing and timing relationships in multi-chip registers.

TABLE OF CONTENTS

BACKGROUND OF THE INVENTION

BRIEF DESCRIPTION OF THE DRAWINGS

DESCRIPTION OF GENERAL BLOCK DIAGRAM

DESCRIPTION OF BLOCK DIAGRAMS OF ARITHMETIC AND SCOM CHIPS

THE IDLE HOLD, AND COND COMMAND BITS INSTRUCTION/ADDRESS/CONTROL WORD FORMAT

TIMING

THE KEYBOARD INPUT MATRIX

THE KEYBOARD INPUT SYSTEM

THE KEYBOARD REGISTERS I/O CONTROL REGISTERS A-E AS IMPLEMENTED IN A SAM

THE PUSH/PULL MATRIX

ARITHMETIC LOGIC UNIT (ALU)

DECODING THE INSTRUCTION WORD

THE I/O CIRCUIT AND REGISTER 5

THE D TIME GENERATOR

THE DISPLAY OUTPUT CIRCUITRY

THE COND CIRCUIT

THE SCOM CHIP

THE HOLDING AND ADDRESS REGISTERS

THE F & G REGISTERS

THE MAIN ROM AND DECODER CIRCUITRY

THE S & D GENERATORS THE GATE CIRCUIT THE CLAIMS

BACKGROUND OF THE INVENTION

Electronic calculators have evolved from the desktop variety utilizing discrete integrated circuit packages to hand-held calculators utilizing complex MOS logic circuitry on one or more MOS/LSI chips. A calculator system adapted to be implemented using only one MOS/LSI chip is set forth in copending patent application, "Variable Function Calculator", Ser. No. 163,565, now abandoned and replaced by Ser. No. 420,999, filed Dec. 3, 1973, assigned to the assignee of this invention. A calculator system implemented utilizing a basic pair of MOS/LSI chips which is adapted for use with an expandable memory system for increasing data and program memory capacity is set forth in "Electronic Calculator", Ser. No. 255,856, now abandoned and replaced by Ser. No. 360,984, filed May 16, 1973 and assigned to the assignee of this invention.

As the consumer demands for hand-held calculators increases for systems providing more functions and more complex functions with increased memory capacity, the challenge to provide such a system with the minimum number of semiconductor chips, each with the minimum number of pin terminals has become major. For example, the standard MOS package for LSI chips contains 28 pins, and accordingly it is highly desirable to design complex calculator chips requiring only 28 output pins. Furthermore, because handheld calculators operate on battery power, and batteries, of course, only have a limited life, then designing the calculator chips system so as to provide minimum power dissipation is of paramount importance.

The electronic calculator system of the present invention fulfills the goals above enumerated in providing large scale semiconductor calculator chips in 28 pin packages by providing an addressing technique between the arithmetic chip and memory chip utilizing a multiplexed technique wherein various condition signals and addresses are communication on a single line in synchronization with cycle times and subcycle times. First cycle and first subcycle timing generators are supplied on the arithmetic chip and second subcycle and cycle timing generators are supplied on the memory chip, and the generators are synchronized during both cycle times and subcycle times by sending a condition bit to the memory chip at a particular cycle and subcycle time.

That is, one line between the chips is utilized for communicating to the other semiconductor chips, including the instruction memory chip, internal operating conditions such as whether or not the calculator is in the calculating or idle mode. This condition is generated at a particular S time and D time for synchronizing the timing generators as well as for communicating the specific status information.

Another pin reduction technique utilized during communication between the arithmetic chip and the memory chip is the multiplexing of various internal operating conditions of the arithmetic chip with a memory address on a single line to generate a multi-bit command word which is communicated to the memory chip. Each bit of the command word is synchronized with a subcycle time, and a first set of bits represents internal calculator functions such as an unconditional branch, hold or the inhibiting of the normal sequencing

of the instruction register, and a condition signal representing results of a test or status of a particular subsystem of the system. The second set bits in the command word represents a memory address only if a bit in the first subset is appropriately set.

BRIEF DESCRIPTION OF THE DRAWINGS

The novel features believed characteristic of the invention are set forth in the appended claims. The invention itself, however, as well as further objects and advantages thereof, will be best understood by reference to the following detailed description of the illustrative calculator system featuring an embodiment of the invention, when read in conjunction with the accompanying drawings, wherein:

FIG. 1 is a pictorial view of the electronic portable calculator of the invention;

FIG. 2 is a simplified block diagram of the multi-chip calculator system of the invention;

FIGS. 3a-3b are complex block diagrams of the arithmetic chip featured in this invention;

FIG. 4 is a complex block diagram of the SCOM chip featured in the electronic calculator of this invention;

FIGS. 5a-5e are representations showing the coding of the instruction word used in the system of the invention;

FIG. 5f shows the decoding of the EXTERNAL signal;

FIG. 5g shows the ROM address as stored in the address register;

FIGS. 6a-6b are timing diagrams showing the timing of various parts of the system of the invention;

FIG. 7 is a representation of the keyboard input matrix;

FIGS. 8a-8d are a composite schematic diagram of the circuit of the "arithmetic chip" part of the system of the invention;

FIGS. 9a-9e are a composite schematic diagram of the circuit of the "SCOM chip" part of the system of the invention; and

FIGS. 10a-10r are detail views of certain circuits used in the system of FIGS. 9 and 10.

DETAILED DESCRIPTION OF SPECIFIC EMBODIMENT

Referring to FIG. 1, an electronic portable calculator 1 of the type which may employ features of this invention is shown in pictorial form. The calculator 1 comprises a keyboard 2 and a display 3. The display, in one embodiment, consists of fourteen digits or characters, each provided by a gas discharge tube, a liquid crystal display unit, an array of light emitting diodes or other display means. The display is preferably implemented using scientific notation, allowing display of ten significant digits. Ordinarily, the display would be of the so-called seven segment or eight segment variety, with provision for indicating a decimal point for each digit. The calculator system of this invention is adapted so as to provide a printed readout, if desired, using either thermal printing techniques or drum printing techniques. The keyboard 2 includes a set of number keys of zero through nine, a decimal point key, and a plurality of function keys including exponential, logarithmic and trigonometrical functions. The exponential and logarithmic function keys include X^2 , the square root of X (\sqrt{X}), the reciprocal of X , ($1/X$), E^X , the log to the base 10 of X , (LOG) and the natural log of X , ($\text{LN } X$). The trigonometrical functions include the arc sine, arc

cosine and arc tangent of X , the sine, cosine and tangent of X , and the hyperbolic sine, hyperbolic cosine, and hyperbolic tangent and arc hyperbolic sine, arc hyperbolic cosine and arc hyperbolic tangent. Other function keys include the store, (STO), and recall, (RCL), keys are respectively storing and recalling a number in/from the memory registers in the SCOM chip. The enter exponent, (EE) key, allows exponent entry of the number displayed in scientific notation. A $+/-$ key is provided for changing the sign of the displayed number. An exchange key, (X:Y), is provided for exchanging operator and operand in an arithmetic function. Other more conventional keys are supplied including the clear all key, (C), the clear entry, (CE), and the $+$, $-$, \times , \div , and $=$ keys. A sigma key, Σ , allows incrementing a number stored in the memory register directly. An X factorial key, (X) is provided as well as a degrees to radian/radian to degrees conversion key, (D/R), and a degrees/radian switch to set the calculator for operation in either degrees or radians.

Referring now to FIG. 2, there is shown a functional block diagram of the multi-chip calculator system of this invention showing the arithmetic chip and SCOM (Scanning and Read Only Memory) chip, hereafter described in detail, interconnected with peripheral chips providing expanded calculator capacity and capability. This invention is principally directed however to the arithmetic and SCOM chip pairs enclosed in the dotted lines 15, which chip pair provide one operable system without the peripheral chips. The arithmetic chip 10 generates a plurality of control signals to the SCOM chip 12, to an external ROM chip 13 providing for increased instruction word storage capacity, to the external multi-register chip set 14 providing external data word storage capacity, to the external programmer chip 16 providing a means for programming specific subroutines in the calculator externally, and to an external printer chip 18 for controlling an output printer responsive thereto (not shown). The output printers may be of conventional design with adaptations to the printer chip 18, but preferably are of the thermal printer type or the drum printer type.

The control signals generated by the arithmetic chip 10 include the control signals:

EXTERNAL (EXT) indicates that the arithmetic chip is addressing SCOM storage and indicates which ROM storage (constant or program) is being addressed, and further communicates in multiplexed bit fashion the HOLD and COND control signals;

The HOLD bit in EXT indicates that an interrupt is desired in the normal sequencing of the ROM in the SCOM to allow additional executions by the system before the next instruction word is to be executed;

The CONDITION (COND) bit in EXT indicates that a condition latch has been set indicating status of a particular flag or the results of a comparison of flags;

IDLE (IDLE) is indicative of the idle condition of the data chip, i.e., whether the data chip is actually in the calculating mode (non-idle) or in the display or scanning mode (idle), and provides synchronization of the timing generators of the SCOM to the timing generators of the arithmetic chip;

Flag A (FLGA) is the serial output of the Flag A register in the SAM at an output rate determined by COND;

Flag B (FLGB) is the serial output of the Flag B register in the SAM of the arithmetic chip or is the B1 or first bit of the B register output.

Segment (SEGA-SEGG) is the data output of the Data Registers for actuating the seven segment display per digit to indicate a 0-9 numeral per digit according to the D times.

Display Time (D time) comprises timed signals 1 each an instruction cycle of sixteen S times duration, wherein the D times are generated in cycles of sixteen so that D times precess from the particular D time of the preceding cycle;

Keyboard Inputs (K lines) are signals from the keyboard for entering externally commands to the arithmetic chip;

Instruction Words (IRG) indicate the particular instruction word comprising thirteen bits (I_0-I_{12}) stored in a particular SCOM memory storage unit;

Busy (BUSY) represents the condition of peripheral chips such as the printer, as determined for example by the printer chip 18 that the printer is not/is busy and can/cannot receive another command for printing.

Input/Output (I/O) are data lines conveying data bits from any of the various data registers and memories located in the arithmetic chip, SCOM chip, and 10-register chips.

Referring again to FIG. 2, the arithmetic chip 10 provides output data information from Registers B and/or A and Flag Register A to the segment drivers 17. Necessary information which is provided is: position of the comma, position of the decimal point, actual data results to be displayed from the "B" and/or "A" register and data to be displayed from the Flag A register. The segment drivers 16 comprise conventional driver circuits for actuating the above-mentioned displays 3, here shown to have a seven segment display plus decimal point per digit, with one digit actuated per D time. Thus for a 16 digit display in scientific notation driven by 16 D times, there are up to 14 digits in the mantissa, 2 digits for the exponent, with 2 digits utilized as annotators for the mantissa and exponent being strobed non-exclusively.

The SCOM chip provides the D times to the digit drivers 20 for selectively scanning in sequence the digits of the display 3 and the keyboard. Scanning of the display is explained in detail in the above-mentioned application Ser. No. 420,999. The D time strobing of the keyboard is set forth subsequently.

The SCOM chip 12 is responsive to EXT and IDLE command signals from the arithmetic chip and generates in response thereto the D times, the instruction word I_0-I_{12} (IRGA and IRGB) and data from the constant ROM on the I/O lines, all of which is communicated back to the arithmetic chip.

The ROM chip 13 depicted is one of the expandable set of peripheral chips allowing expanded calculator capacity. The ROM chip is responsive to the EXT and IDLE commands from the arithmetic chip for providing a 1024- additional instruction word capacity per additional ROM chip.

The multi-register chip 14 is another set of peripheral chips providing expanded data storage capacity of up to ten registers to the calculator system of this invention. The multi-register chip is responsive to Flag A, IDLE, and I/O information from the arithmetic chip for providing recall data through the I/O lines in return to the arithmetic chip.

The printer chip 18 is responsive to the I/O information from the arithmetic chip, the EXT, and IDLE commands from the arithmetic chip for printing in accordance with data on the I/O lines. If an impact printer

chip is utilized, the Flag A command is utilized from the arithmetic chip.

For minimizing pin count on the arithmetic and SCOM chips, and for maximizing silicon area utilization, both chips feature separate timing generators for providing S and D times, with the timing generator on the SCOM chip dependent upon the arithmetic chip for synchronization. Furthermore, instead of providing separate signals on separate lines between chips representing various conditions of the arithmetic chip, such as flags and sync signals, as heretofore utilized in earlier multi-chip calculator systems, the two-chip system of this invention features a multiplexed command signal from the arithmetic chip to the SCOM chip wherein each bit of a subset of bits in the command word represents the particular condition required to be transmitted. For example, the EXT signal communicated to the SCOM chip transmits a PREG (program register) signal in the S_0 bit indicating that the SCOM chip is being addressed, transmits a second signal in the second bit at time S_1 for indicating the COND condition, and transmits the HOLD condition in the third bit at time S_2 indicating that the ROM address register is not to be incremented. Heretofore, three separate signals and pins were required for transmitting this information. Although the arithmetic chip 10 and the SCOM chip 12 provide a basic operating calculator system as herein disclosed, the chip pair provides a basic system which anticipates adding peripheral storage and output function chips, preferably implemented in MOS/LSI utilizing novel methods of addressing for minimizing pin count.

Shown in FIGS. 3a-3b and FIG. 4 is a detailed functional block diagram of the arithmetic chip and the SCOM chip depicted in the calculator system of FIG. 2. A detailed description of the individual functional blocks will be discussed subsequently with regard to FIGS. 9 and 10, with only a general functional description of the basic "two-chip" system here set forth. It is understood that in the block diagrams of FIGS. 3a-3b and 4, a connection represented by a single line may represent a plurality of actual hardware interconnections, and for ease and simplicity of illustration, a single line may represent a plurality of different functions. The calculator system of this invention includes on the SCOM chip a main program ROM 20 responsive to decode and gating means 21 and 22, respectively, which selectively couple the address word in the address register 23 to the ROM for controlling which ROM location is being addressed. A holding register 24, in combination with an add-1 circuit 25, selectively generates a new ROM address in the register 23 when a branch instruction word has been executed. As will subsequently be discussed, branching will be implemented utilizing a relative technique wherein, instead of conventionally jamming in a complete new address, the old address will be incremented positively or negatively by a relative numerical amount to generate the new address.

An instruction register 26 is responsive to the output of the ROM 20 for storing the instruction word I_0-I_{12} which enters the instruction register 26 in parallel. Thereafter, the instruction word is serially communicated to the arithmetic chip through the output buffer 27 which is under control of the ROM 20. A decode PLA 28 is responsive to the instruction register 26 after the instruction word has been transmitted through the buffer 27 and re-entered into the instruction register 26. Then the decode PLA 28 decodes the instruction

word providing store and recall commands to the registers F and G, 29 and 30, respectively, and to the constant ROM 35, through the I/O control circuit 31.

After the instruction word leaves the buffer 27 for transmission to the arithmetic chip, it is further communicated to the adder 32 and to the branch comparator 33, wherein, if the I_{12} bit of the instruction word indicates a branch is to be executed, the branch comparator enables the holding register 24 to accept the new instruction word from the adder 32, which adds a positive or negative increment to the old address storage received from the address register 23 to generate the new address.

The constant register address 34 is responsive to a command word EXT from the arithmetic chip for addressing a constant in the constant ROM 35 which provides up to sixteen 16-digit 4-bit constant words. Logic recall circuitry 36 couples the constant register address 34 to the address decoder 37 of the constant ROM 35.

Further implemented on the SCOM chip is an S counter 38 and a D scan generator 39 for generating the S and D time timing signals of this calculator system, which D times D_0 - D_{15} are outputted to the digit drivers and keyboard as shown in FIG. 2. Both generators are synchronized by a command from the arithmetic chip which command is synchronized with the D and S times on the arithmetic chip.

The arithmetic chip of FIGS. 3a-3b is generally responsive to the instruction word IRG from the SCOM chip and to external operator inputs from the keyboard and other peripheral chips for executing the particular instruction word and performing the indicated arithmetic operation. The main data registers in the calculator system of this invention are Registers A-E, 50a-50e, respectively. They are implemented in sequentially addressed memory (SAM) form which are driven by a commutator 51 which also drives a push-pull matrix 52 for generating timing signals. Also implemented in SAM format are four 1-bit registers utilized as two flag registers, Flag A, 53a; Flag B, 53b; the keyboard register 54, a multi-purpose register; and a subroutine register 55. It is understood that although the term "register" is here utilized as descriptive of the SAM implementation, this is only a "black box" type description as internally there is no actual shifting of data. Accordingly the SAM "memory" elements which are sequentially addressed are not "shift registers" in the literal sense. Data in Registers A-E, as will be discussed subsequently in detail, is acted upon by the adder circuit 55 as controlled by the selector gates 56, ALU control 57, carry/borrow generator and BCD corrector control circuit 59, and BCD corrector 61.

Selector gates 62 control exchanging and recirculation of Registers A-E. The calculator displays its results by outputting the contents of Register B and/or Register A, preferably Register A, and the Flag A register to drive the segment decode PLA 63 which provides the output display as shown in FIG. 2. Zero suppress circuitry 64 provides leading zero suppression so that only the most significant non-zero digit is first exhibited.

A fifth 1-bit register, Register 5, of four digits duration, is a multi-purpose register responsive to the output of the adder circuit 55, to I/O lines, and to the instruction word from the Flag Decode PLA 72 as controlled by R5 control 66. R5 control 66 provides control data inputs and control inputs to Register 5 responsive to decoded instruction information. A feature of this invention is the means allowing four bits of the in-

struction word to be entered into Register 5 upon the "NUM \rightarrow R5" command. Since Register 5 is coupled to the main SAM registers and to the ALU, such provision allows use of a subset of the instruction word as data for execution. Such a feature facilitates software generation of data required in various subroutines.

The push-pull matrix 52 provides timing information to the D time generator 67 which is a ring-tail counter to generate one D time or instruction cycle comprising sixteen S times. Generator 67 counts backwards from 15 to zero in cycles, causing the D times to appear to precess in sequence. The D/S Test and Flag Mask Comparator 68 is responsive to S and D times for generating sync pulses and masking signals for flag operations, respectively, and for setting COND circuit 80. The wait generator 69 is responsive to the D time generator and to a decoded instruction word from decoder 72 for generating a wait command to logic and encoder 77 for controlling keyboard scanning.

The decimal point/D comparator 71 is responsive to D times and to Register 5, 65, for generating a decimal point at the proper timing location and for ending zero suppress.

Decoding of the instruction words from the SCOM chip is done locally on the arithmetic chip. That is, the instruction words are initially decoded in the mask decode PLA 83 for generating masks to the arithmetic logic unit for communicating such information as decimal point location, mantissa, and exponent location. The instruction word is then communicated to the D/S flag mask comparator 68 and also to the flag decode matrix 72 which controls input and output of the flag registers 53a and 53b through the flag input/output control 73. The instruction word also is communicated from the mask decode PLA 83 to the R decode matrix 73 and then to the sigma decode matrix 74 for controlling the selector gates 56 and 62 for register selection/functioning.

External inputs are supplied to the arithmetic chip by a keyboard operator through the keyboard 11 via K lines to an encode PLA 75. A particular keyboard actuation commands to the hardware clear circuit 76 generates proper commands for initializing and resetting the calculator upon battery actuation. The encode PLA 75 provides encoded K line information to the logic and encoders 77 and to a K comparator 78. The logic and encoder 77 selectively supplies D time and K coordinates in serial form to the keyboard register/subroutine register control 79 for entry into the keyboard register 54. The K comparator 78 allows determination that a specific K line was not actuated, or conversely determines which K line, by a process of elimination, was actuated. This information is communicated to a condition circuit 80 which is a versatile latch circuit responsive to a plurality of functions for providing status of various conditions at preselected times. Idle latch 81 is responsive to the flag decode PLA 72 and provides information to the display output controls that the calculator is or is not in an idle or non-calculating state for appropriately blanking the display. This information is further communicated to the idle terminal as indicated for transmission to the SCOM chip for synchronizing the S and D generators there.

Another important feature utilized in the calculator of this invention is a technique utilized in reducing power dissipation on the chips by utilizing depletion loads for the decode circuits. That is, the decode circuits such as decoders 28, 72, 73, 74 and 83 are imple-

mented as programmable logic arrays, now well-known in the art, which utilize load devices implemented in depletion mode MOS. To achieve optimum levels of power dissipation, the loads are periodically clocked as needed so as to dissipate power only when needed during the cycle.

For clearer understanding of the novel, useful and unobvious features of this invention, a more detailed functional interrelationship of the above circuit components follows.

The program memory 20 comprises a novel 13 × 1024 ROM for storing the control program and advantageously features virtual grounding, a novel method of precharging, and a novel layout pattern reducing the number of ground lines. By implementing a virtual ground ROM as the program memory, significant power reduction and silicon economy are achieved.

Instruction words I_0 - I_{12} are read out of the ROM 20 one word at a time in bit-parallel into an instruction register 26 which functions as a parallel-to-serial converter for serially communicating the instruction word to the arithmetic chip through the buffer 27 on the IRG line. Buffer 27 is controlled by the ROM 20 via the chip select, CS, line which indicates that the particular ROM 20 has indeed been addressed allowing the instruction word read out of the instruction register 26 to be communicated to the data chip. Otherwise, an instruction word from another ROM on another chip, for example, the ROM chip 12 would be exported under control of its CS. When buffer 27 has been enabled by the chip select line, the instruction word is transmitted on the IRG line to the data chip and is thereafter re-entered into the instruction register 26 to be subsequently decoded by decode PLA 28. Such a re-entry and subsequent decoding is a feature of this invention, whereby the multi-functional use of register 26, first as a parallel to serial converter of the instruction word, and then as a register for decoding the instruction word, reduces component and software requirements.

Furthermore, because the calculator system of this invention is adapted to accommodate up to 8 SCOM or ROM chips, or any combination thereof, such a re-entry and subsequent decoding allows the up to 8 ROM/SCOM memories to be coupled in parallel at the buffer 27 into the two-chip system with minimum control and timing requirements.

On the arithmetic chip, the instruction words from the ROM 20 are decoded locally in several decode PLA's, including the mask decode PLA 73 and the sigma decode 74, the functions of which will be subsequently discussed. Data is stored in registers 50 which are basically sequentially addressed random access memories organized as five data registers of sixteen digits each. Register E, 54c, although similarly implemented as Register A - Register D in a basic SAM configuration, has no direct output terminals, functioning only to exchange its data with the data in the A register. The flag registers 53 and keyboard 54 and subroutine 55 registers are 16 bit registers, implemented as a SAM, each bit of which is separately programmable for providing optimum utility. The keyboard register functions mainly to receive encoded controls from the keyboard for eventually interrupting and controlling the main ROM 20 on the SCOM chip 12. The subroutine register, like Register E, has no direct external outlet, instead its function is limited to exchange with the keyboard register, functioning chiefly as a memory for storing program address during a jump instruction, so

as to remember the location to which control is to be returned after the subroutine has been executed. All operations on the data entered into the registers 50 is carried out in an arithmetic logic unit on the arithmetic chip which is of the bit-parallel, serial-digit type, and features a novel carry-propagate binary adder 55. The novel binary adder utilizes bidirectional IGFET switches for switching IGFET current sources to provide a binary adder especially adapted for MOS application in general and specifically in calculator ALU's. Exclusive-or circuitry conventionally utilized in the input and output circuitry has been eliminated by incorporating it into the adder logic itself to reduce required circuit size. The 4-bit register, Register 5, is responsive to the arithmetic logic unit and I/O control 82 and functions to store the decimal point location along with any other four bit number for entry into the A, B, C and D registers or into the adder. The BCD corrector 61 appropriately adds six (for addition) or ten (for subtraction) for correcting the output of the binary adder back into BCD.

Responsive to the instruction word from the SCOM chip, the sigma decode 74 and the R decoder 73 respectively control recirculate and exchange of the various registers and control which registers are coupled to the arithmetic logic unit (ALU). The mask decode PLA 83, in response to the instruction word from the SCOM, generates the appropriate mask for aligning the proper set of digits of the data word, such as the mantissa or the exponent, for operation thereon by the arithmetic logic unit.

The visual display 3 in FIG. 1 displays the contents of the B register and/or the A register in combination with the Flag A register. The segment decode PLA 63 is programmable such that either the output of the A or the B register may be decoded to drive appropriate segments in the display, and is programmable so as to accommodate up to 7 segments plus decimal point. A zero suppression circuit 64 provides suppression of the leading zeros so as to provide up to 10 digits of significant digits in a 12 digit display utilizing scientific notation. Suppressor 64 is responsive to the push/pull matrix 52 for beginning and ending suppression, and is also responsive to the decimal point generator and B register.

Inclusion of Register E in Registers 50 is a feature of the invention. Sigma decode matrix 74 controls the selector gates so as to allow exchange of Register E with Register A. Thus, the contents of Register E, although having no direct outlet, may be indirectly displayed via exchange with Register A or the contents may be accessed upon by the arithmetic logic unit by exchange with Register A. Such a feature allows five registers to access a four input ALU, i.e., an N input adder addressed by N + 1 registers.

Another feature of this invention is the application of the subroutine register 55 in combination with the keyboard register 54 in a SAM configuration. Because the keyboard register functions mainly to address a specific location in the main ROM on the SCOM chip, the ability to store that location in, for example, the subroutine register via an exchange instruction, saves both hardware and software requirements. For example, by storing this information in the subroutine register, the keyboard register is free to perform other functions without endangering the loss of the memory address. Thus, when the subroutine has been executed and control of the program is to be returned to that address, another

exchange between the keyboard register and the subroutine register allows that address in the ROM chip to be directly addressed via the keyboard register upon a specific command "P Reg" which communicates a "1" at time S_0 on the EXT line.

The "P Reg" command supplies both control instructions and ROM address on the external line in multiplexed format on the SCOM chip. This address accesses address register 23 on the SCOM chip which is capable of addressing each of the addressable locations in the ROM 20, whereby the instruction stored in each location is read out into the instruction register 26. Usually the address register is incremented by one for each instruction cycle, as controlled by timing means and the ADD-1 circuit 25, so that the instructions of a particular subroutine stored in the ROM are normally read out in sequence. However, branch instructions appearing at the instruction register 26 are recognized by the branch comparator 33 and interrupt the sequencing of the ROM address by a relative addressing method. That is, the "old" ROM address is incremented positively or negatively in accordance with the instruction word from one of the ROM's available on either the SCOM or other external chip and the new location is stored in the holding register 24. For example, an incremental address read out from the specific ROM location to the instruction register 26 and transmitted to the arithmetic chip through buffer 27 on line IRG is transmitted to the adder 32 along with an actuation signal from the branch comparator indicating a branch condition. The previous ROM address stored in the address register 23 is also communicated to the adder 32 via line 40 and the sum is transmitted via line 41 to the holding register 24. During the next instruction cycle, the new address word is read into the address register in parallel from the holding register 24.

The branch comparator 33 is responsive to the instruction word and to the command word from the arithmetic chip transmitted on the EXT line. If the I_{12} (or S_{15}) bit of the present instruction word is for a branch, and if S_0 is not a "1" allowing a "branch" possibility, and if the S_1 digit bit thereof, the COND bit, matches the condition bit at S_{14} of the previous instruction word, then a branch results. If a COND match doesn't result, the address is incremented by one. The COND bit on the EXT line serves to indicate to the ROM that a special condition has been executed which may interrupt the ROM sequencing.

To address one of the constant registers in the constant ROM 35, or in one of the constant ROMs 35 if a plurality of SCOM chips are utilized in the system, the instruction word from the proper ROM 20 in one of the ROM/SCOM chips is communicated to the IRG pin and then communicated into all the instruction registers 26. The instruction word communicated to the arithmetic chip inhibits the S_0 bit to provide a logic 0 at S_0 . If the instruction is not for a branch as above explained, then the instruction word is decoded by decode PLA 28 to generate "recall constant" command. The command word from the arithmetic chip on the EXT line having a zero at S_0 is decoded in the constant register address circuit 34.

Upon a "recall constant" command received from the decode PLA 28 recall constant and constant A-constant D signals appropriately address the constant ROM 35 for recalling one of the sixteen constants therein contained in sixteen, four bit constant registers. The constant ROM 35 comprises a 64×16 (or 16×4

$\times 16$) unit array to generate the sixteen, 16-digit, 4-bit constants.

Decode PLA 28 also provides input/output controls to register F 29 and register G 30 which are additional data registers providing increased data storage suitable for memory storage under the operator's control. Data is stored into and recalled from the registers F and G, respectively, through I/O 1 . . . I/O 8 lines, in response to the decode PLA 28 which decodes the instruction word from the ROM. As explained with respect to "recall constant", the instruction word from the SCOM inhibits the S_0 bits preventing "PREG". Only then will the F and G registers be addressable through decoder 28 as the I/O control 31 is under the control of the "recall constant" signal, which is generated in response only to the appropriate chip select signal.

Inputs from the keyboard 11 are entered into the arithmetic chip on seven keyboard lines or K lines 13 which are encoded into a 3-bit binary code by the encode PLA 75 for entry, along with the appropriate D time, into the KR Register 54. Data is entered into the encode PLA for an entire D time when a line is discharged, and then the lines are precharged awaiting a new code. As will be subsequently explained, because of the relatively long duration of a key depression on the keyboard as compared to the relatively high clock operating rates, a single key depression actuates the PLA 75 for sufficient instruction cycles to complete the routine called for; for example, upon expiration of one instruction cycle when the lines are discharged, the same keyboard entry is again reimpressed upon the decode PLA 75 for the next several instruction cycles upon the occurrence of the respective D time of each cycle. The detailed explanation and description of the timing of the calculator system will be described hereinafter with regard to FIGS. 5a and 5b.

The K inputs are encoded by the PLA 75 and strobed into a K comparator 78 and into control logic and encoder 77. The K comparator 78 is also responsive to selected bits of the instruction word IRG which are programmed so that a comparison of the IRG bits and the encoded keyboard information provides information representing either that a specific K line has not been actuated, or provides information determining which K line has been actuated by a process of elimination. If a "match" is accomplished at the K comparator 78, the output thereof on line 85 causes the condition circuit 80 to set the COND latch, which setting has a predetermined meaning to the calculator at a particular S/D time combination.

The encoded K information is also communicated to the logic and encoder 77 which also selectively actuates the condition circuit 80 in combination with internally generated "wait" signals from the WAIT generator 69, and from the BUSY input terminal which communicates with other output chips, such as the printer. Upon a command from the flag mask generator 68, logic 77 allows the encoded K information to be serially combined with encoded D times and entered into the keyboard register 54 through the keyboard register/subroutine register control 79 in accordance with the condition of the COND latch and the WAIT generator. Shown in FIG. 3 is D time D_{15} actuating logic 63 which automatically kicks the calculator out of a SCAN cycle if no keys are found actuated.

Thus, specific keyboard inputs, encoded as K line data and D time data, are loaded into the keyboard register 54. A "P Reg" command forces the ROM on the

SCOM chip to be addressed to a location as determined by the contents of the keyboard register.

The keyboard register provides functions other than addressing the main ROM and the constant ROM in the SCOM chip. For example, the tri-state buffer 86 on the external line EXT is controlled by instruction words so that data also may be entered onto the arithmetic chip as well as communicated from the arithmetic chip. Upon such an instruction, data on the external line such as from the programmer chip 16, may be entered into the keyboard register through the keyboard register control circuit 79. Another function of the keyboard register utilizes an instruction word which causes the contents of the keyboard register to be incremented by one, allowing it to function as a counter. If the number in the keyboard register represents an address of a constant in the constant ROM on the SCOM chip, then a succession of constants may be recalled during successive instruction cycles so that a subroutine may perform several iterations utilizing progressively smaller constants according to an arithmetic progression. That is, since the keyboard register recirculates and has an add-one circuit, information therein may also be incremented by one, thereby providing a method for addressing constants in sequence in the constant ROM by doing a succession of "recall constant" instructions with the keyboard register incremented by one each time. Utilizing the keyboard register in such an iteration technique is an important feature which allows implementation of the subroutine function with a minimum of software requirements.

Four bits of the contents of the keyboard register also may be read into register R5 when a KR R5 instruction word is ordered. Because R5 is coupled into the registers A-D through the adder, then a number generated in the keyboard register may be inserted into the SAM memories for, for example, use in a software routine in the ROM requiring numerical data. By loading data in the keyboard register directly into the registers A-D in the SAM, instruction space in the ROM is saved in that otherwise a subroutine would be required to generate this data.

The instruction word I_0 - I_{12} on lines IRG is comprised of a 3-bit sigma "S" field or selector gate field I_0 - I_2 , a 4-bit "R" field or register field I_4 - I_7 , a 1-bit "sub" or subtract field I_8 , a 4-bit "M" or mask field I_9 - I_{11} , and a 1-bit branch field I_{12} . At S_{15} after the instruction word has been serially clocked onto the IRG line which started at S_3 , the 4-bit M field of the instruction word and the I_{12} branch bit is decoded by the mask decode matrix 83. The mask decode PLA functions so as to provide a "mask" for allowing manipulation of only a selected part of the data word, i.e., the mantissa or the exponent. This function is needed only when an instruction is commanded, as opposed to a branch, so the mask decode matrix is only responsive to the M field when the branch bit is a zero. The mask decoder is further responsive to the push-pull matrix 52 which provides encoded state times, the decimal point and exponent timing information. The mask decode matrix provides an output signal DMSK or digit mask for providing the mask for the selector gates coupled to the sigma decode matrix 74. Also provided are masks coupled to the ALU control 57 for providing a mask for any particular part of the data word to be added. Line 87 provides control to the BCD corrector 59 for preventing improper carries out of certain mask fields. Bits I_9 - I_{12} also generate a constant N as decoded by the mask de-

code PLA 83 for input to the binary adder, as controlled by the R field, bits I_4 - I_7 , as decoded by the R decode 73.

At S_{13} - S_{15} , the 3-bit sigma field is clocked into the sigma decode matrix 74. The sigma field is decoded for selecting, transferring or recirculating data among the registers A-E. That is, lines 89 control the exchange of data between the A and B registers and between the C and D registers and controls recirculation of the A, B, C or D registers. The sigma field also controls the selector gates so as to allow entry of the Reg. 5 back into the adder via lines 88. Sigma control lines also control entry of the output of the BCD corrector 61 back into the SAM for right and left shifting.

The R or register decode matrix 73 receives the R field during S_6 - S_9 of the instruction word which controls the selector gates 56 for determining what main register in the SAM is coupled to the ALU. Also, bits I_4 - I_7 are generated to the K comparator 78 as earlier explained.

The flag mask comparator 68 receives the R field I_4 - I_7 of the instruction word and compares it with the encoded S time for providing "FMSK" or "flag mask" when a flag operation is commanded. Output from the flag test and compare logic 68 is coupled to the COND condition circuit 80 as an indication that the condition exits that, for example, two flags are the same. The flag decode PLA 72 is responsive to the I_0 - I_3 bits for generating flag register commands including recirculate, exchange, R5 to keyboard register, test flags and setting and zeroing idle latch. Bits I_0 - I_3 are also decoded and supplied to the K comparator 78.

Operation of the A-E registers and the ALU is briefly as follows. Assuming data in the SAM register is awaiting operations, the instruction word subsequently is decoded into its M, R and sigma fields. If, for example, the instruction is for an add routine, the sigma field may cause the data in Reg. A to be entered into Reg. B, awaiting a second data input from the keyboard to be entered into the keyboard register which is then entered into Reg. A through Reg. 5 as above described. Under the control of the R field from the instruction word, the respective registers A and B are coupled into the ALU binary adder. The M field of the instruction word provides masks from decode PLA 83 supplying to the ALU the location of the decimal point, and what part of the word is the mantissa. Reg. 5 in response to the mask decode PLA 83 receives at the edge of the digit mask signal the output of the ALU which is the decimal point location. The mantissa part of the output word from the ALU is then coupled back into Reg. A through a BCD corrector 61 as needed. At a proper time the A Reg. is then outputted through segment decode PLA 63 to the display.

In displaying the decimal point information in Reg. 5, a routine generally utilizing the D time generator 67, the decimal point/D comparator 71 and the R5 register 65 is utilized. That is, as above described, R5 contains a number representing the location of the decimal point position. That number is coupled to the DPT/D comparator 71 along with the encoded D times.

When the D time representing the timing of the system matches the adjusted decimal point input, then at time S_{15} the decimal point output at pin 1 is actuated for the duration of the instruction cycle by way of the idle latch circuit. A particular decimal point indicator on the display is energized during the particular D time at the desired location in the display in response to pin

1.

Another feature of this calculating system is the leading zero suppression of the display. The D/S flag test and mask comparator 68 provides a sample signal every instruction cycle when the S time encode and D time encode is coincident so that the time of occurrence of the sample signal is one of precession, i.e., S_{15} of D_{15} , S_{14} of D_{14} , S_{13} of D_{13} , etc. because D times precess. This sample signal gates the segment decode PLA 63 which, coupled with a zero suppression gate 64, provides zero suppression of the most significant digit first. Suppressor 64 is responsive to the DPT generator for ending zero suppression upon occurrence of a decimal point, and zero suppress is ended by a bit communication from the B register during an EE entry. Also, the Push/Pull matrix supplies Start/Stop zero suppression signals every D time.

The initial program which the calculator executes upon actuation by a user is the power up clear routine. The power up clear circuit 76 which clears and initializes the calculator upon user initial actuation provides a first input to the external buffer 86 control circuitry generating a "1" at S_0 and zeros thereafter on the EXT line. This is accomplished by setting the S_0 "flag" of the KB register and setting bits S_3 - S_{15} to zero in the KB register. The KQ input from the keyboard at time D_{15} provides another hardware "clear" input on the EXT line for initializing the calculator. That is, upon power up, or a key down at D_{15} on line KQ, the clear circuit 76 forces a "1" at time S_0 to be outputted on the EXT output line and causes zeros during the remaining S times. At time S_0 , the SCOM sees a 1 and realizes that the subsequent instruction during S_3 - S_{15} is an address which is zero. The ROM is thereby reset back to location zero and reads out of location zero an instruction word to begin its initial sequencing.

The IDLE, HOLD and COND Command Bits

Sequencing of "new" instructions coming from the ROM to the arithmetic chip at times are desirously interrupted. That is, if the calculator is waiting for a particular D time before executing the next instruction, the ROM must send out a succession of "WAIT" instructions. The ROM is then instructed to stop incrementing and for it to "HOLD" at its present location and to continue sending out the instruction stored in the instruction register location. To accomplish this, the old address in the address register is recirculated through an inhibit increment circuit. An example is during a keyboard scan requiring a complete D or instruction cycle.

On the standard programming of the two-chip system of this invention, the S_2 or "HOLD" bit is controlled by the presence of a wait instruction from wait generator 69 or the test/wait busy or test/scan decoded command having its respective test condition fulfilled. These are commands for the ROM to stop incrementing at its particular location until reactivated by the data chip. During the "one" state of hold, the holding register 24 on the SCOM chip receives back the same previous instruction, which generates either the wait or the scan instruction. The same command is read back into the holding register as the "HOLD" signal inactivates the add-1 circuit 25 and the instruction register 26. The calculator stays in this recirculating loop until the presence of a D_{15} signal which changes the state of "HOLD" allowing entry of a new address into the address register and then a new address from the instruc-

tion register, as incremented, to be entered into the holding register. One example of such a wait or scan function is scanning of the keyboard where a wait until D_{15} is necessary. This ensures that the scan is started on D_{15} to assure scanning of all keyboard lines. Otherwise, if a scan started at D_{13} instead of D_{15} , remembering that the D times count backwards, a complete scan would comprise D_{13} - D_0 - D_{15} , without scanning D_{14} . At the next time D_{15} , the calculator is kicked out of the wait/scan instruction as a hardware function at time D_{15} and a new instruction word is executed.

The signal "IDLE" communicates to external chips whether or not the data chip is in the "idle condition" and changes state at a predetermined S time and D time to synchronize the SCOM's timing generators. This synchronization is a feature of the invention as a separate sync signal and transmission line is not required, as in conventional systems. In the idle condition, the calculator's outputs to the segment terminals Seg A-Seg G and DPT are actuated at D time rate, and the machine is awaiting further information. When the calculator is not in the idle mode, it is actually computing, and the external display is blank except for the flag output which is displayed at S time rates. Thus, the idle output will either be in a high or low state representing a calculating/not calculating condition. Idle is responsive to the idle latch circuit, above discussed with respect to hold, which selectively actuates idle in response to instructions such as "set idle" or "zero idle" whether or not data is actually being operated on. For example, the idle "instruction" is utilized to transport synchronization information to the SCOM chip at $D_{14}S_0$ wherein the S counter 38 is synchronized at S_0 and the D scan generator is set at D_{13} by respective edge detector circuits. By programming a "WAIT" D_{15} instruction followed by a "set idle" the idle terminal transmits a level change of logic one to logic zero at $D_{14}S_0$ (remembering that D_{14} is the next instruction cycle after D_{15} as D times precess). This is a feature of the calculator system which allows a one pin reduction of the conventional requirement.

Idle, in addition to providing idle conditions and sync timing, also performs other functions. That is, if flag condition information is being sent to other chips, Idle is utilized to indicate at what rate the flag information is being sent. That is, whenever data is being displayed, i.e., the calculator is in the idle condition, the flags are being sent at the same timing rate as the register information, i.e., one particular flag is transmitted during each instruction cycle or D time. This enables the flag to actuate functions such as decimal points, minus signs, or commas depending upon the specific program.

When the calculator is not in an idle mode, and Idle is in the "other" condition, the flags are being transmitted at state time rates; that is, one flag per state time or sixteen flags per instruction cycle or D time. The flag during this time may be utilized to selectively actuate other chips depending on whether or not a particular figure flag is set. Therefore, Idle controls whether other chips will look at a particular flag by knowing whether or not the calculator is in idle.

The condition circuit 80 provides an output COND at S_1 during the second bit of EXT for providing to the ROM a condition branch instruction. That is, if upon a particular test command the condition circuit and the COND bit is set and the S_{14} or COND bit of the branch instruction is also set, a new branch address generated and stored in the holding register is transferred to the

address register causing the ROM to jump or branch thereto. If the condition circuit is not set in relation to the S_{14} bit, the next instruction word in sequence in the ROM is executed. For example, if the software routine requires a branch instruction when a particular flag is set, then at a particular time in the instruction cycle the flag is tested, and if the condition circuit is set in relationship to whether the flag was "set", then the ROM branches to the location of the desired routine. If the condition circuit is not set with respect to the flag condition, then the next sequential instruction from the original ROM location is executed.

The feature of a condition circuit and COND signal provides the machine the capacity of decision making dependent upon conditions which are under software control increasing versatility. Other software controlled conditions which may set or reset the condition latch circuit is the depression of a particular key on the keyboard input, setting the latch. In response to this particular setting of the condition latch when a keyboard key is depressed, the keyboard scan is terminated. The condition latch is also set if, during any add or subtract operation, a carry out of the last digit of the register or a borrow out of the last digit is required. In other words, the condition circuit functions to indicate an overflow condition. The condition latch may also be set upon a particular "test flag" operation, wherein if the flag is set then the condition latch will also get set and conversely.

The "busy" signal is an input to the arithmetic chip which may be tested in a manner similar to that of testing a flag. For example, upon a "test busy" instruction, if there is an input on the busy terminal, software causes a setting of the condition circuit. If a printer chip is included in the expandable calculator system herein described, it may be desirable for the calculator to stay in the idle mode until the printer chip has finished printing out the results. Then an input on the busy terminal from the printer chip indicates to the arithmetic chip that the printer is active and cannot take any more data in to be printed. The arithmetic chip monitors the busy terminal and if a signal is thereon, the condition circuit will be set, allowing the calculator to perform a conditional branch to a particular wait condition until the printer is finished printing and ready to receive more information. The busy terminal may also be used to create a "wait" condition until the signal subsides and also to provide feedback to the arithmetic chip as to the status of other peripheral chips such as the 10-register chip in addition to the printer chip in a manner similar to that above-described.

The input/output circuit 82 is used to both output data from registers in the SAM to external chips and to input data from the external chips to the data chip. Whether or not data is being input or output and to which registers the data is channeled is under software control.

The Flag A, FLGA, output is utilized to display particular conditions of the calculator, such as error, arithmetic overflow, or entry overflow conditions. The output may also be utilized as a comma output which is stored in the Flag A register. Flag A is under control of the Idle signal and may be utilized for communication to other chips while the calculator is actually in the not idle or computing mode. As earlier discussed, in the calculating or not idle mode, the flags appear at the Flag A output once every given S time. This particular flag information is communicated to other chips, for

example, the 10-register chip, which in combination with idle directs the 10-register chip to store the conveyed data in a particular data memory therein. Utilizing the flags in this way is a feature of this invention as an almost unlimited amount of expansion is possible with peripheral chips in combination with the arithmetic and SCOM chips. The outputs labeled Seg A-Seg G are the outputs by which the 4-bit output code from the SAM registers is communicated to the display indicating which numeral is to be displayed. The two-chip system of this invention has segment decoding circuits 63 which may be programmed responsive to register B and/or to provide a programmable number of segments. That is, some types of displays require seven segments, as illustrated, to display the data.

The output labeled DPT is the decimal point output which is actuated at the particular D time responsive to the DPT/D generator 71 as controlled by Reg 5. No external decoding is necessary in the embodiment herein described, as the DPT output directly actuates the particular decimal point in the display.

The FLGB output terminal may also be utilized for outputting Flag B information. It is possible therefore in extremely complex systems using many peripheral chips wherein flags are used as means of controlling the chips, to output both sets of Flag A and Flag B. The Flag A output pin 11 has been discussed above. By outputting both Flag A and Flag B information, the amount of available control capacity is doubled. It is understood that in computer technology a flag is merely one binary bit indicating a preprogrammed condition which may be used to trigger circuitry.

INSTRUCTION/ADDRESS/CONTROL WORD FORMAT

Shown in FIGS. 5a-5f are representations of the instruction word I_0-I_{12} as decoded by the various decode PLAs above-mentioned. FIG. 5a denotes the thirteen bit instruction word I_0-I_{12} as it appears in the instruction register 26 on the SCOM chip after it has been read out of the ROM 20. The formats for operations on branches (or increments) are different as seen in FIGS. 5a and 5b. The I_{12} bit is shown containing a "1" indicating that the instruction word is either an increment or a conditional branch command and not an instruction. That is, if bit I_{11} , the COND bit, matches the COND bit of external communicated from the arithmetic chip at time S_1 , then bits I_1-I_{10} of FIG. 5a represent a relative branch address. That is, bits I_1-I_{10} represent an incremental number which is to be added or subtracted from the previous ROM location as commanded by the I_0 bit in FIG. 5a to generate a new address as shown in FIG. 5g. If the I_0 bit is a zero, then the relative branch address in bits I_1-I_{10} is to be added to the old address. If I_0 is a 37 1", then the relative branch address is to be subtracted from the old address.

If the I_{12} bit of the instruction word in the instruction register 26 is a zero, then bits I_0-I_{11} represent an instruction which is decoded locally on the arithmetic chip and in the decode PLA 28 on the SCOM chip. For example, bits I_8-I_{12} are decoded in the digit mask PLA 83 to provide the M or masking operations defined for an M field of M_0-M_{15} and to provide a constant N. Bits I_4-I_7 are decoded by the R decode PLA 73 to provide the register or R operation indicated. Bits I_4-I_7 are also decoded in the D/S flag test and mask comparator 68 for providing FMSK as shown in FIG. 5c. Bits I_0-I_2 are decoded in the sigma decoder 74 for controlling regis-

ter select while the I_3 bit actuates the logic and encoder 77 for indicating add or subtract. In FIG. 5c, the I_0 - I_3 bits are decoded by the flag decode PLA 72 for generating the F or flag commands for controlling the flag registers. Decode PLA 28 decodes the instruction word for providing store and recall of the F and G registers.

Bits I_0 - I_7 also actuate the K comparator 78 for determining which K line of the keyboard has been actuated upon a key depression. In FIG. 5e, bits I_0 - I_3 , which are decoded in the flag decode PLA 72, also generate the wait or W instructions for placing the calculator in a non-operational or waiting condition until a specified condition such as the arrival of a specific D time encoded in bits I_4 - I_7 . Bits I_4 - I_7 are decoded in the flag mask comparator 68 for generating the condition whose occurrence controls wait.

In FIG. 5f, the external command EXT is generated from the data chip in performing a "P Reg" or constant ROM recall. In bit S_0 , the "P Reg" command with a "1" therein represents the condition that the arithmetic chip is desiring to jam in a specific address into the ROM for causing an unconditional jump, such as at power up clear. A zero in bit S_0 represents the conditions that the arithmetic chip may be either addressing the constant ROM, executing a conditional branch or merely communicating COND and HOLD signals. The P Reg jam-in circuitry is inactivated during constant recall allowing the ROM to increment normally. The second bit, occurring at time S_1 , is the COND bit for communicating to the SCOM chip the status of the condition latch, indicating that a conditional event has occurred to which the ROM should respond. The COND bit at time S_1 controls whether or not a conditional branch is executed as determined by the most recent instruction word from the ROM. That is, if the S_1 bit of external matches bit I_{11} of the branch instruction, then the ROM will be incremented by the relative branch address as earlier discussed.

The third bit of external, occurring at time S_2 , is the HOLD command indicating that the SCOM is to inhibit the incrementing of the ROM and "HOLD" the ROM instruction word for a specified period. The HOLD bit is responsive, for example, to the "WAIT" generator 69.

Bits S_3 - S_{15} are always specific absolute addresses. If the S_0 bit is a "1", then the S_3 - S_{15} bits represent a specific address in the ROM to which it is to branch. If the S_0 bit is a zero, then the S_3 - S_{15} address may be that of a constant location in the constant ROM 35 for doing a "recall constant" or a conditional branch to the specific main ROM location. Upon a "recall constant instruction", as decoded from the decode PLA 28, then the preceding EXT communication with a zero at time S_0 will recall the specific constant.

Depicted in FIG. 5g is the coding format for the ROM address word as stored in the address register 23 on the SCOM chip. As the 1024 13-bit instruction words are stored in the ROM 20 in a $64 \times 16 \times 13$ bit array, bits A_0 - A_6 address the 64 rows of the ROM, while the A_7 - A_9 bits address the 8 columns per row for selecting the proper column addressed. Bits A_{10} - A_{12} represent chip select and are decoded so as to enable buffer 27 so as to control whether or not the instruction word from the ROM 20 is communicated to the arithmetic chip.

TIMING

The entire system operates on two externally provided clocks O_1 and O_2 , and two internally generated clocks P_1 and P_2 . The frequency used is 250 KHz for O_1 , O_2 . The clock generators may be conventional and are not shown herein.

One set of clocks $O_1P_1O_2P_2$ is referred to as a state time, and represents the time for one bit from each of the main registers A, B, C and D to be operated on in parallel by the ALU, etc. The BCD arithmetic used in the invention requires one full set of clock pulses for each digit, so sixteen sets or state times are needed to perform arithmetic operations on all 16 digits in a register. Sixteen state times represent one D time or instruction cycle, as seen in FIG. 6b.

Individual address lines in the registers 50-55 are energized only for three of the clocks O_1 , P_1 , O_2 , rather than all four; these groups of three are also referred to as state times S_0 - S_{15} . The same state times generated to operate the address lines of the SAM register 23 also operate or time the remainder of the system.

D times generated directly from state times S_0 - S_{15} are used to scan the keyboard and the display. As seen in FIG. 6b, the D times count down, D_{15} , D_{14} , D_{13} . . . D_0 while the state times count up, S_0 , S_1 , S_2 . . . S_{15} ; this feature aids in the zero suppression technique since leading zeros to be suppressed are on the left or MSD first while the ALU must operate from right to left or LSD first.

THE KEYBOARD INPUT MATRIX

In FIG. 7, there is seen a sixteen by seven matrix showing the keys from the keyboard arranged as scanned by the sixteen digit timing signals D_0 - D_{15} , and as sensed on the seven outputs at KN-KT, from which keyboard information is entered into the system. If a "1" voltage appears on line KP at D_{13} time, then the EE key is depressed, etc. The combination of a digit time and a sense line identifies a key, and these 16 and seven line items are binary encoded within the machine to appear as 4 and 3 bits respectively; TABLE 1A shows the format for loading keyboard and digit time information into the keyboard register 54, with the code of TABLE 1B being used for K information. If a key at D_{10} , KP is down after a keyboard scan, the keyboard register will contain the word of TABLE 1c.

TABLE 1A

MSB	K_a	K_b	K_c	D_k	D_4	D_2	D_1 LSB
-----	-------	-------	-------	-------	-------	-------	--------------

TABLE 1B

K' line	K_a	K_b	K_c
KN	0	0	0
KO	0	0	1
KP	0	1	0
KQ	0	1	1
KR	1	0	0
KS	1	0	1
KT	1	1	0

TABLE IC

X	0	1	0	1	0	1	0
	KP			D10			

DETAILED DESCRIPTION OF THE CIRCUITS THE KEYBOARD INPUT SYSTEM (FIGS. 8b5-6, 8b9-10)

Keyboard of K information communicated from the KN-KT bias elements 100 enters the data chip via pins 8-14. Bias elements 100 bias lines KN-KT to a logic 0 state so as to effectually precharge the lines in anticipation of signals from the keyboard. Precharge gates 101 precharge each of the lead-in lines from pins 8-14 at time $S_{15}0_1$ through $S_{15}P_1$. A keyboard scanning technique similar to that set forth in "Expandable Function Electronic Calculator", Ser. No. 255,856, copending herewith, strobes the keyboard lines in accordance with D times to provide the signals entering on pins 8-14. Each line is strobed for one D time, and the input data appearing on lines KN-KT appears for one D time.

For convenience, description of the keyboard will be exemplified for line KN only, but it is readily seen that the other six keyboard information lines are structurally similar and operate in the manner described with respect to line KN. By precharging the lines 102 by means 101 at time S_{15} to logic zero, the keyboard data is effectively entered into the input circuitry at the next succeeding S time, or S_0 , with actuation indicated by a logic "1".

At time S_00_1 , inverted K information is entered into the register 103 comprising three clocked transfer gates such that data is allowed to the PLA 104 at time S_0 and remains there for one D time until time S_{15} for decoding. Data is decoded for an entire D time to allow time for executing the keyboard command. At time $S_{15}P_2$, the line 102 input to the inverter is discharged to circuit ground, clearing for the next input signal, and the line 103 is precharged to V_{DD} awaiting the next input signal. The succeeding K line signal is typically the same signal, as a keyboard operator actuates a K line for some 1000 instruction cycles per key depression.

Decode means 104 comprises a programmable logic array (PLA) used for generating a code indicating which specific K line was actuated on the keyboard. Programmable logic arrays, which function as a NAND gate, are now well known in the art. Encoder 104 provides first and second sets of encoded output data, $\bar{K}_A - \bar{K}_C$, $K_A - K_C$, generated as a logic NAND combination of selected K lines. The first set is the logic complement of the second set, a feature which advantageously provides data for determining when more than one key on the input keyboard has been depressed during a D time, i.e., an error condition caused by simultaneously punching two keys. The KN line is seen as an input to \bar{K}_A , K_B and K_C for the \bar{K} set and is not an input for the K set. \bar{K}_A is seen to be the logic combination of KN . KP . KR . KT.

One of the lines 107 from the storage circuit 103 generates on line 108 an output signal providing a hardware clear signal. Although a contact is shown on each K line, they are programmable and only one will be implemented. At time S_00_1 , this signal is gated into logic arrangement 110 via line 109, so that at $D_{15}S_1$, in re-

sponse to line 111, a zero is generated and gated to the keyboard register input circuitry for generating a 1 at S_0 to be transmitted to the SCOM chip, indicating that an address is being transmitted through EXT during S_{315} , which address is zero. Further, if a power up latch signal is received during initial powering up of the calculator, logic arrangement 110 similarly outputs a logic 0 for resetting the calculator by transmitting a "1" in the S_0 bit of EXT, followed by a zero address.

A set of logic OR gates 112 logically ORs the respective K line information with the respective digits of the instruction word I_0-I_2 , I_4-I_7 into a comparator arrangement 113 for determining if a particular K line has been activated. That is, fields I_0-I_2 of the instruction word and I_4-I_7 are set to a particular logic state; for example, all 1's except for one logic 0 bit which is utilized to test the particular K line. If the "match" condition of the comparator circuit 113 is realized, then the particular K line corresponding to that logic 0 test but has been activated. That is, at time S_{15} , all K lines are precharged to a logic zero and inverted and then one is subsequently activated by key depression to a logic zero. Thus, all K lines except one provide logic "1" bits to the OR gates 112. The instruction digits generate all 1's except for a test zero respectively coupled to the OR gates 111, and if the zero from the instruction bits and the zero on the actuated K line are coincident, then comparator 113 will indicate a match by outputting a 1. A program may be executed testing whether a single line has been actuated, or a set of tests may be performed to determine which K line has been actuated. Comparator 113 is enabled by the M8 mask via line 114 from the digit mask PLA 83 in response to the instruction word decoding for a keyboard operation.

The output of the comparator 113 is coupled to an exclusive OR logic arrangement 116 and to a logic gate 117 for generating the HOLD signal. The exclusive OR gate 116 is a feature of this invention in that it prevents erroneous keyboard inputs or erroneous "COND" signals to the calculator caused by the dual depression of keys. That is, both sets of data \bar{K} and K are logically combined in gate 116 such that if and only if K is the logic complement of the \bar{K} set, is a signal generated preventing the COND circuit 118 from being set, allowing recognition of the keyboard instruction input. For example, upon depression of more than one keyboard key, logic gate 116 provides a logic "1" to the logic arrangement 119 which generated a "zero" $\overline{\text{CONDA}}$ signal during "test/scan" causing the condition latch 118 not to be set to a logic zero, i.e., remains a logic one. This logic "1" state of COND is communicated via line 120 to gate 121 controlling entry of the keyboard data into the keyboard I/O control 79. That is, only when the condition circuit remains unset does the gate 121 provide logic zeros to the keyboard I/O control allowing entry of the keyboard data via line 122.

Gate 121 is also responsive to line 114 communicating the M8 mask which indicates a keyboard operation, and is responsive to the I_3 bit of the instruction word, wherein a zero therein represents a scan keyboard operation, as indicated by FIG. 5d.

HOLD signal generator 117 selectively generates the HOLD command on line 127 creating the HOLD bit at time S_2 in the external command. Generator 117 is responsive to several decoded instruction commands including the WAIT command on line 125 as generated by the WAIT generator 69. During this instruction, HOLD is generated until a specified condition is met, such as for a specific D time or until the "busy" line is

no longer "busy". To prevent the calculator from becoming "stuck" in a WAIT loop, generator 117 is automatically forced to change state at D_{15} via input 128.

A command from the flag decode PLA 72 on line 124 allows monitoring of the "busy" input terminal on pin 29 such that "busy" is tested or causes a WAIT cycle in accordance with the decode of the I_3 digit on line 126. If the busy terminal is actuated, typically the output peripheral is presently active and is unable to accept any more information, or is "busy". Therefore, a WAIT cycle is generated until the peripheral is able to accept more data.

The serial encoder 129 is responsive to the encoded K line information, \overline{K}_A , \overline{K}_B , \overline{K}_C from PLA 104 on lines 105, and is further responsive on line 130 to encoded digit times as generated by the D time generator 67. During times S_2 - S_5 , as generated from the push/pull matrix 52 and transmitted via line 131, the encoded D times are read into the encoder 129. These are serially transmitted via line 122 to the keyboard input/output control 79 during S_2 - S_5 . During times S_6 - S_8 , the encoded K line information is serially transmitted. In this manner, a 7-bit encoded word is entered into the keyboard register 54 representing a particular K line which was actuated at a particular D time for indicating which key was depressed on the keyboard.

THE KEYBOARD REGISTER I/O CONTROL (FIGS. 8b1, 8b6)

The keyboard register I/O control 79 comprises a complex set of logic gates for controlling whether data is entered into the keyboard register 54 from the subroutine register 55 via line 132 as controlled by an $\overline{EX} \cdot \overline{KR} \cdot \overline{SR}$ command from the flag decode PLA 72, or whether the external data is entered via line 133 as controlled by the $\overline{EXT} \rightarrow \overline{KR}$ command from the flag decode 79, or whether the contents of R5 is entered via line 134 as controlled by the $\overline{R5} \cdot \overline{KR}$ command, or whether the 7-bit encoded word from the keyboard entry as earlier discussed is entered via line 122 as controlled by the latch 121.

The complex logic gates in I/O control 79 also controls whether or not data is communicated through the EXT terminal through the tri-state output buffer 135. Tristate output buffers are now well known in the art, and exhibit three output states, a logic "1" state, a logic zero state, and then a "floating" state wherein the output exhibits an "open circuit" condition. The buffer thereupon may be utilized to allow use of the EXT pad as an input terminal to the I/O control 79. For example, upon an $\overline{EXT} \rightarrow \overline{KR}$ command from the flag decode PLA 79 on line 136, a logic zero is supplied to the NAND gate pair which feeds the tri-state buffer 135, generating a pair of logic 1's to the input of the buffer. This generates the "floating" output state allowing the data on the external line to be entered into the keyboard register.

To transmit data on the EXT line, such as during a P Reg command to cause an unconditional branching of the ROM on the SCOM chip, a "1" must be generated at time S_0 on the EXT line. This is realized via line 138 from the push/pull matrix 52 which supplies a logic zero to the inverter 139 providing a logic "1" on line 140 to gate 141. Gate 141 generates a zero to the latch input circuitry of the tristate buffer, which generates the desired "1" at time S_0 .

Referring again to inverter 139, it is responsive to either line 138 as described or is responsive to the output

of the complex logic gate 142 which controls inputs into the keyboard register as controlled by the flag PLA as earlier described. Transfer gates 143 and 144 respectively control actuation of inverter 139 upon actuation of a 0_1 clock, which 0_1 clock is supplied only to one of transfer gates 143 and 144 as determined by the output of logic circuit 110. That is, if a logic zero is generated upon the output of logic circuit 110 indicating a power up or hardware clear condition, then clock 0_1 is supplied to transfer gate 143 as earlier described. If a zero is output from logic circuit 110, then 0_1 is supplied to the transfer gate 144 allowing input to the keyboard register as controlled by gate 142.

The S_1 or second bit on the EXT line is the condition bit, and OR gate 145 is responsive to \overline{S}_1 and the \overline{COND} bit via line 146 for generating COND at time S_1 to the input latch circuitry to the tri-state buffer 135. \overline{S}_1 is also generated to gate 141 to enable the input latch at time S_1 .

In a similar manner, at time S_2 , the HOLD bit is supplied to OR gate 147 at time S_2 which is supplied to the input latch circuit to buffer 135. \overline{S}_2 is also supplied to NAND gate 141 for enabling the latch at time S_2 .

The output of the keyboard register 54 is transmitted on line 148 to complex logic gate 142, which is communicated to the inverter 139 and then to gate 141 via line 140 as earlier described in accordance with particular instruction words such as FMASK and set/zero KR. OR gates 145 and 147 supply 1's to the input latch circuitry allowing the contents of the keyboard register to be supplied through NAND gate 141 to the tri-state output buffer.

The output of the keyboard register on line 148 is also supplied to complex logic gate 149 which controls entry into the subroutine register 55. Appropriate commands from the flag decode PLA 72 control entry into the subroutine register 55 by controlling gate 149.

Other functions of the keyboard register 54 allow recirculation of the data therein, and an incrementing of "1" via a $\overline{KR} + 1$ command from the flag decode matrix 72. Upon such a $\overline{KR} + 1$ command, NOR gate 150 provides an incremented output on line 151 which is reentered into the keyboard register 54. Such a function allows the KR register to function as a counter for calling in sequence constant ROM locations when needed in an iteration loop of a subroutine.

Above-described is operation of the keyboard register as it periodically controls operation of the SCOM chip by communicating on the EXT line. Such a keyboard register implemented in a sequentially addressed memory (SAM) configuration and the other logic circuitry providing the appropriate control bits at times S_0 - S_2 is an important feature of this invention allowing flexible communication with other chips in the calculator system with a minimum of pin requirements, thereby maximizing silicon area utilization.

NOR gate 150 is responsive to line 152 from the push/pull matrix which disables the input to the keyboard register during times S_0 - S_2 . This disabling prevents any of the command signals of times S_0 - S_2 from entering the keyboard register 54, allowing these command signals only to affect the EXT word.

The flag input/output circuitry 73, comprises first and second complex logic gates 153 and 154, responsive to instruction words and data lines from other registers.

Gate 153 controls input to the Flag A register 53A while gate 154 controls entry into the Flag B register

53B. Outputs are respectively transmitted on lines 154a and 155a to the "FLGA and FLGB" lines and are further recirculated to each gate 153 and 154 so that the Flag A and Flag B registers can be both recirculated and exchanged. Furthermore, the R5 register may be input to either Flag A or Flag B registers upon appropriate commands and each flag may be inverted.

Both flag registers, like the keyboard register, have separately addressable bits, each of which may be output to other chips. For example, the Flag A output line 154a is communicated to Flag A logic circuitry 155 (FIG. 8d2) which is also responsive to the idle latch 156 for regenerating an output at the FLA terminal, pin 15. The output of the idle latch 156 is either changing at an S time rate or at a D time rate, so that the output of logic 155 will be changing accordingly, so that the FLA information will either be communicated to other chips at an S time or a D time rate.

The Flag B information is transmitted to NAND gate 157 (FIG. 8b10) for controlling the Flag 8 output terminal at pin 30. NAND gate 157 is also responsive to the first bit of the B register 50b so that either Flag B or B1 of the B register may be outputted at pin 30.

The Flag B and busy terminals at pins 30 and 29 respectively are programmable in that, instead of inputting the "busy" and outputting "Flag B or B1" information at pins 29 and 30 respectively, the information may be programmed via contacts 158 and 159 so that any unused K lines may be utilized as the outputs or the output. Thus, 2 pins may be deleted to achieve a 28 pin package instead of the 30 pin package shown. Contacts 158 and 159 are programmable and, although shown as one contact per each of the seven K lines, only one of the contacts on each line would be implemented if a 28 pin package were desired using "busy" and "FLAG B".

REGISTERS A-E AS IMPLEMENTED IN A SAM (FIGS. 8c1-8c7)

The main registers of the calculator system, Registers A, B, C, D and E, are implemented with a random access memory arrangement which is operated in a manner similar to a set of shift registers, as set forth in co-pending patent application, Ser. No. 163,683. All registers in the SAM are comprised of four separate rows in BCD format. For example, the A register comprises rows A1, A2, A4 and A8 so as to provide a data word having four bits per digit. These bit rows are interleaved for saving space in interconnecting the registers and the ALU through the selector gates on the chip. Each row of the registers includes 16 cells, 157, or one cell for each bit, with each cell being a conventional three transistor MOS RAM memory cell. All the memory cells 157 in the SAM are the same, and there a total of $16 \times 5 \times 4$ or 320 cells in the main A, B, C, and E registers. The Flag A and B registers, and the subroutine and keyboard registers, earlier described, also are implemented in the SAM and comprise the same memory cell and function as will be described with respect to the main A-E registers.

Vertical lines in the SAM are address lines 158, of which there are 17, which are lines driven by a commutator 51 comprising a 17 stage ring counter which circulates a zero in synchronization with state times. There are 17 address lines and 17 cells in a register while only 16 S times so that the S_{16} cell is also outputted at time S_0 .

Only one of the address lines 158 is energized at any one time, and the energized line shifts from right to left

in the order $S_0, S_1, S_2 \dots S_{15}, S_0$, etc. These S times are used throughout the calculator system, and they are seen depicted in FIG. 6B. In FIGS. 8b2-8b3, a recirculate signal of logic zero is generated and coupled back to the beginning stage by line 159 when the output of the S_0 - S_{14} stages all are a logic 1. At time P_1 , the logic zero is inverted to a logic 1 by inverter 160, and at time P_2 , the logic 1 is reinverted to a logic zero by inverter 161 and impressed upon the S_0 address line until the next P_2 . However, at the top of the SAM and at the other end of the line 158, it is seen that gate 162 is also responsive to the P_2 signal, so that the S_0 address line is discharged to a logic 1 during P_2 . Therefore, the address line S_0 resides at a logic zero or V_{DD} state during $0_1P_10_2$ to generate the subsequent S time.

Looking now at the S_0 column and the B1 bit row in the B register, when the logic zero energizes or actuates the S_0 address line, the MOS transistor 163 becomes conductive allowing output of the stored data in the particular cell. That is, conduction of transistor 163 couples the data storage capacitor 164 to the output line 166. If previously a zero has been stored on the gate of storage transistor 164, then circuit ground would be coupled to output line 166. Similarly, if a logic 1 had been stored on the gate of storage transistor 164, then transistor 164 would be nonconducting, and line 166 would remain in its precharged condition, as precharged during the P_2 clock by transistor 168.

To input information into the S_0B1 bit, the S_1 address line is actuated to a logic zero causing transistor 165 to become conductive which allows entry onto the gate of storage capacitor 164 of whatever data is impressed on input line 167. It is thus seen that information read into the cell via line 167 is stored on the gate of storage capacitor 164 in true form, but that when the information is read out of the memory cell, it is inverted, or it is in false logic.

The inputs to the line 167 for storing specific data in the memory cells 157 are generated from the adder circuit 55 on lines 169 and 170. NOR gate 171 couples either the output of the adder back into the appropriate memory cell, or it couples the contents of the left adjacent memory cell into the right adjacent memory cell to accomplish a shift right function. That is, if it is desired that the data in bit S_1 in the B1 row of the B register be right shifted into the S_0 bit of the B1 row at time S_1 , the contents of the S_1 cell is read onto line 166 in inverted form. A decoded instruction word actuates gate 172 via a $B \rightarrow Y$ command calling for the contents of the B register to be supplied to the Y input of the adder. Thereupon, the data is thrice inverted back to NOR gate 171 where it is impressed upon the input line of the B1 row during the same S_1 time during which it is read into the S_0 bit in its true form.

Line 169 supplied to NOR gate 171 also supplies data which is to be left shifted by one bit upon a shift left command. That is, when the output of the S_0 bit, for example, is supplied to the Y input of the adder as above described, and delayed two and one-half S times through transfer gates 173, 174 and 175 and is coupled through AND gate 176 via the shift left command, then the data is transmitted by line 169 through gate 171 back onto input line 167 for entry into the S_2 bit, thereby performing a left shift.

Upon other appropriate commands, the main registers may be recirculated and exchanged. For example, upon a recirculate B command, data from the B register on line 166 is gated through OR gate 168 into com-

plex gate 179 after a one and one-half S time delay so that the data is read back into the same cell. To exchange data between registers an EXAB command to complex gates 179 and 180 causes the output of the A register to be communicated to gate 179 and the output of the B register to be communicated to the gate 180 so that one S time later each data bit is read back into the cell which the other bit came from.

An important feature of this invention is the inclusion of the fifth main register, Register E, in the SAM in combination with Registers A-D. Register E has no external port coupled directly to the adder 55, so that the only functions performable in Register E are recirculate and exchange with Register A. Such limited functions, however, are extremely useful in saving software instructions and hardware requirements in increasing access to the ALU of the calculator system. For example, by including a fifth register having the capacity to exchange its contents with one of four registers directly coupled to the ALU, then effectively the adder is responsive to an extra register without the hardware requirements of a direct connection to the ALU. That is, by storing a fifth data word in Register E, then the adder is responsive not only to Registers A, B, C and D, but upon completion of the operation of the data word in Register A, the contents of Register E may be exchanged therewith and operated on by the adder 55. In effect, then, the calculator system of this invention features an N input adder responsive to N + 1 registers.

THE PUSH/PULL MATRIX (FIGS. 8b1, 8b3)

Coupled to the bottom of the subroutine register 55 is a push/pull matrix 52 which functions to generate a number of timing signals. Push/pull matrices in combination with SAM registers are now well known and are explained in copending application, Ser. No. 255,856. Four lines 318 are outputs of the matrix 52 and provide an encoded indication of the 16 S times S_0 - S_{15} which are supplied to the digit mask PLA 83 and to the strobe generator and flag mask comparator 68. A "HEX" signal on line 319 is shown which may be programmed to allow the adder 55 to operate in hexadecimal rather than in binary. Having a gate, as represented by a zero, on every S line except S_0 , it is seen that HEX is effectively inactivated for this embodiment for all S times except during S_0 . During S_0 , such information as decimal point location which requires use of a hexadecimal format is in the adder, so the adder is disabled at time S_0 by "HEX". PLA 1-PLA 5 signals on lines 320 are communicated to the digit mask PLA 83 so as to control duration or timing of the respective mask signals. On lines 321 and 322 are shown generated end zero suppression and start zero suppression signals, respectively, which are supplied to the zero suppression circuit 64. A start zero suppression signal is shown to begin at time S_{14} and last through time S_2 . An end zero suppress signal is generated at time S_3 , for causing display of the last significant zero during time D3 as will later be discussed. Coupled directly to the S lines from the commutator 51 are shown lines generating the \bar{S}_{15} , \bar{S}_8 , \bar{S}_7 , \bar{S}_6 , \bar{S}_2 and \bar{S}_1 signals. These timing signals are utilized in various circuits on the chip requiring particular S time actuation.

THE ALU (FIGS. 8c3-4, 8c7-8)

Another feature of this calculator invention is the precharged carry propagate adder 55 which operates in parallel on the four bits comprising a digit which are se-

rially communicated from the SAM. Carry propagate adders are generally well known in the art as taught in copending patent application, Ser. No. 176,667, "Precharge Arithmetic Logic Unit", now abandoned and replaced by Ser. No. 441,917, filed Feb. 12, 1974, which precharges only the carry/borrow circuit and the binary full adder circuit which is the subject matter of U.S. Pat. No. 3,602,705, which utilizes IGFET transfer gates generally. The adder of this invention, however, implements the sum function, $S = C(AB + \bar{A}\bar{B}) + \bar{C}(AB + \bar{A}\bar{B})$ and the carry propagate function $K = AB + C(AB + \bar{A}\bar{B})$ in a particular mode especially well suited for complex systems utilization requiring low power dissipation and a minimal silicon requirement. Adder 55 utilizes a precharge technique for conditioning the entire adder prior to each adding/subtracting step for minimizing power dissipation. Complete circuit operation follows.

The arithmetic logic unit consists basically of the bit parallel, serial digit binary adder 55 and the BCD corrector 61 including the carry/borrow logic. The adder performs subtractions by 2's complement addition.

The four parallel stages 217-220 are respectively responsive to the "1", "2", "4" and "8" outputs from two registers of the SAM. The adder unit responsive to the respective bit inputs generate outputs on lines 221-224 which are coupled into the BCD corrector 61 and into control logic for either a further coupling into R5 or back into a SAM register. Each adder stage 217-220 is responsive to a \bar{SUB} and SUB instruction command, respectively, commanding the adder to provide the difference or sum of the inputted bits. \bar{SUB} and SUB are generated by a decode of the I_3 instruction bit in the R decoder 73. If \bar{SUB} is present, then the stages 217-220 perform 2's complement subtractions.

Considering now the X_1 - Y_1 stage, 217, NOR gates 178 and 179 are respectively responsive to the first bit of the A and C registers and to the first bit of the B and D registers and to the sigma in line 225 from the digit mask PLA 83. The respective register lines convey the appropriate bit from the respective register, while the sigma in line 225 conveys the "2" bit of a constant as generated in the digit mask PLA 83. Sigma in lines 2-8 on lines 226-228 convey the "2", "4" and "8" bits of the constant to the adder from the digit mask PLA 83. This constant is generated in response to bits I_{11} - I_{12} of the instruction word.

In effect, then, NOR gates 178 and 179 allow the adder 55 to be responsive to five sources in various combinations. Including the feature of having a fifth SAM register, or Register E, as earlier discussed, then the adder 55 is actually responsive to a sixth source. Looking then at the "1" bit of the adder, the adder has two inputs for adding a first number X and a second number Y wherein X may be selected from one of three sources and Y may be selected from one of three sources, allowing a two input adder to be responsive to six sources with a minimum of pin connections and logic controls.

The inputs to the "1" bit are respectively communicated to the carry propagate circuit or the summing circuit either in true or complement form, with the complements generated by inverters 182 and 183. SUB and \bar{SUB} control whether or not the true or complement of the Y input is supplied to the carry propagate circuit and to the summing circuit.

The serially connected gates 184 and 185 in parallel with serially connected gates 186 and 187 provide an

exclusive OR function of the inputs. These inputs during an add instruction (SUB) are as follows:

X to 184, \bar{Y} to 185, \bar{X} to 186 and Y to 187. The commonly connected sources of gates 185 and 187 provide an output for the carry propagate signal to the "2" bit. The common drains of gates 184 and 186 are coupled through precharge device 190 to line 196 which is selectively connected to V_{DD} for precharging. That is, prior to the appropriate S time during which the calculation is to proceed, the lines are precharged to the common drains of gates 184 and 186. Gate 191 coupling the precharge device 190 to the commonly connected drains is actuated by line 201 which conveys the carry/borrow signal from the previous digit. If a carry for an add operation or a borrow for a subtract operation has been previously generated, gate 191 will be actuated via line 201. Gate 191 couples the precharge line 196 and the precharged load 190 to the common drain terminals of gates 184 and 186. In effect, then, the second term of the carry propagate function K has been implemented by logically "ANDING" the carry signal with gates 184-187 consisting of $C(\bar{A}\bar{B} + \bar{A}B)$.

To implement the first term of the K function, gates 188 and 189 are serially connected having X and Y coupled thereto during addition. One terminal of the serial connection of gates 188 and 189 is connected to the output carry propagate line 205 for the "1" bit and the other terminal is coupled to the precharge line 196. It is seen that such operation is dynamic wherein the lines are first charged during the P_1 cycle of an S time, and then selectively discharged upon the proper input conditions. During an add cycle, a carry is desired if either the X_1 or Y_1 addends constitute a "1" and a carry from the previous digit has been generated. This carry is executed by providing a P_1 charge upon actuation of gate 191 representing the previous carry upon the serial connections of gates 184-185 and 186-187 representing X-Y and X-Y addends. Upon the condition that there is a previous carry in addition to one addend equal to a 1, then the precharge of V_{DD} volts or a logic zero is communicated to the output line 205. Similarly, upon the condition that both the addends X_1 and Y_1 are 1, a carry must be generated, so that upon the conditions that X_1 and $Y_1 = 1$, then the precharge condition on the drain of gate 189 is communicated to the carry propagate output line 205.

To implement the sum equation, another set of serially connected gates 192-193 and 194-195 is utilized wherein each serial set is responsive to either the complement's or the true's form of the X_1 and Y_1 inputs. The drains of commonly connected gates 192 and 194 are connected to the P_1 precharge line 196 and the sources of gates 193 and 195 are commonly connected as an output to exclusive OR circuit comprising AND gate 197, NOR gate 198 and NOR gate 199. AND gate 197 is responsive to the output of the serially connected pair and is also responsive to the gate 191 conveying the carry from the previous digit. NOR gate 198 is also responsive to the previous carry and is also responsive to the output of the serial pair. The output of the exclusive OR gate is gated at time 0_2 of the S time of the add/subtract function through inverter 200 to provide the output according to the formula $S = C(\bar{A}B + \bar{A}\bar{B}) + \bar{C}(\bar{A}B + \bar{A}B)$.

To perform a subtraction function, the adder utilizes a 2's complement addition whereby the subtrahend is inverted and the carryout of the fourth bit is added back into the first bit. The inversion required is imple-

mented utilizing inverter 183 and the transfer gates on the \bar{SUB} line 180 to supply the inverted Y_1 input to those gates previously responsive to Y_1 .

By using such a precharge technique, in combination with IGFETS, the carry propagate adder of this invention is provided achieving minimum power dissipation and minimum silicon. Furthermore, since the precharge during P_1 is only one-fourth duty cycle of the S time, an adder is provided which operates with minimum time delays for high frequency operation. The "2", "4" and "8" bits 218-220 operate similarly as above discussed.

To provide the carry and borrow signals from the "8" bit as required in the above-described adder, the carry/borrow out of the "8" bit is inverted and communicated via line 204 to complex gate 208. Gate 208 is also responsive to a selected combination of the outputs of the adder 55 via line 229 so that any illegal codes which are generated will be detected. For example, because the adder 55 adds in binary and the X and Y inputs are in binary coded decimal, sometimes the output of the adder 55 on lines 221-224 constitute a number greater than 9 which is an illegal code. Accordingly, gate 211 which is responsive to the "4", "8" and "2" outputs provides a signal to gate 208 indicating that an illegal code has been received. If the output of the adder 55 generates a number greater than 9, i.e., the "8" bit is a 1 on line 230 and either the "4" or "2" bits on lines 231 and 232 respectively are 1's, then gate 211 provides a 0 to complex gate 208 indicating that a numerical correction in the form of a carry must be added.

Complex gate 202 generates the carry/borrow signal in response to the C_8 carry output on line 204, to the \bar{SUB} input on line 180, and to the carry/borrow reset, CBRS input or by the \bar{SUB} input in combination with an output from gate 208 indicating the absence of an illegal code, gate 202 provides a borrow signal to provide the required "add back bit" in 2's complement. It is seen that, if gate 208 provides an output indicating that an illegal BCD code has been generated by the adder, then no borrow signal is generated.

During the addition function, if a C_8 is generated out of the "8" bit, the 0 is inverted and supplied as a logic "1" on line 204 to gate 208. The input to the OR gate of gate 208 is a logic 0 from a \bar{SUB} command on line 181, and the other input to the OR gate is a logic 0 indicating that an illegal BCD code has been generated on the output of the adder requiring a carry. Therefore, the output of gate 208 is a logic 1 which is communicated to gate 202 and since there is no carry/borrow reset input to gate 203, a 0 is generated at the output of gate 202 for actuating gate 191 in the adder.

The output of gate 208 indicating the presence of a carry/borrow signal is coupled to terminal 213 to indicate a carry during SUB instruction by actuating transfer gate 214, and a borrow signal is generated at terminal 213 in response to a \bar{SUB} command actuating transfer gate 233 which causes the output of gate 208 to be inverted.

Shown connected to terminal 216 is a \overline{HEX} input generated from the digit mask PLA 83 which is shown to effectively disable the BCD corrector during S_0 , or any other S time desirously programmable. That is, looking at the push/pull matrix 52, line 216 will become a logic 0 only when the chosen S times S_1-S_{15} are a logic 1. Such an input would be utilized during S_0 when the adder requires a hexadecimal format to accommodate data such as decimal point location.

The BCD corrector 61 adds either the numeral 6 or the numeral 10 to the output of the adder 55 whenever an illegal BCD code is recognized. If the function is an addition, the numeral 6 is added and if the function is subtraction, the numeral 10 is added. The addition of the 6 or 10 increment is provided by gates 209 and 210 for respectively providing 6 and 10. That is, during a SUB or subtract instruction, an illegal code recognized by gate 211 will cause a 1 to actuate gate 212 generating a 0 on line 233. Since $\overline{\text{SUB}}$ is a 0, then the output of gate 210 is a logical 1 which is communicated via line 231 to the adder circuit 234 which adds 1 to the "8" bit output. Line 233 also causes a 1 to be added to the "2" bit during either the subtract or add functions when an illegal BCD code is recognized because in binary a "6" or a "10" has a binary 1 in the "2's" bit.

If an illegal BCD code is not generated during the subtract function, but there is a carry out of the "8" bit, then a logical 1 is generated on line 235 when gate 236 is actuated by the $\overline{\text{SUB}}$ control, so that gate 212 again is driven into the 0 state to activate gate 210.

During the add instruction, gate 209 is activated upon recognition of an illegal BCD code by gate 211 and 211 or by a carry on C_n . In the absence of an illegal BCD code, line 235 does not communicate a logical 1 to arrangement 212 as the gated inverter arrangement 238 causes line 235 to return to a logic 0 state.

During the addition of a 6 or a 10 to convert the output of the adder 55 into binary coded decimal, a carry is sometimes generated out of the "2" bit into the "4" bit and from the 4 bit into the 8 bit. Looking at the "2" bit, a logic 1 at that output coupled with the illegal BCD code as indicated on line 233 causes actuation of transfer gates 239 and 240 allowing the precharge as supplied by line 246 and resistor 241 to propagate as a carry on line 242 into the "4" bit. This carry is added to the output of the "4" bit in arrangement 247 to generate the true adder output on line 249. If the "4" bit had been a 1 prior to correction, and was corrected during an illegal BCD format during addition, then gate 243 is actuated and the carry propagates via line 245 to the "8" bit. The "8" bit output is added to the carry in logic arrangement 248 and the final output is communicated to gate 176. If there had been no carry out of the "2" bit, but there had previously been a 1 on the "4" bit prior to correction, and correction was required, then gate 244 would be actuated and again a carry would be provided via line 245 to logic arrangement 248 incrementing the "8" bit.

Thus, it is seen that the adder 55, the BCD corrector 61 and the BCD corrector control and carry/borrow generator 59 comprise in combination an arithmetic logic unit for operating in binary on BCD information. The carry propagate adder is especially well suited for high speed calculator operation as it employs a precharge technique and requires only a minimum of components to implement both add and subtract functions. Because the adder operates in binary while the inputs are in BCD, the BCD corrector in response to the binary adder outputs and to carry/borrow inputs generate the proper BCD adder output.

DECODING THE INSTRUCTION WORD

The instruction word from the SCOM chip is communicated to the data chip through the IRG terminal at pin 21 to the digit mask PLA 83 via line 249. The instruction word ripples through a 4-bit shift register 250 until at time S_{15} the bits of the instruction word con-

tained in the register 250 are gated into the PLA. That is, bits I_6 - I_7 have ripped through register 250 and are communicated to other PLA's for further decoding.

PLA's are now well known in the art as set forth in copending application, Ser. No. 255,856, with vertical lines representing P diffusions and horizontal lines representing metal strips, and circles at the intersection of the horizontal and vertical lines representing a gate or thin oxide so that MOS transistors are formed. The other P diffusion lines are not shown for simplicity, but on the chip they are implemented and coupled to circuit ground. Logically, a given output line may be considered the NAND logic function of the input such that if a logic 1 is impressed everywhere that there is a circle, then a logic 0 is generated. Conversely, if a logic 0 is impressed at the terminal represented by a circle, then a logic 1 output is generated.

It is seen that the I_{12} bit arriving at time S_{15} is not entered into shift register 250 but is directly entered into the PLA. Therefore, at time S_{15} , instruction bits I_8 - I_{12} are decoded to generate the mask field MO-M15 shown in FIG. 5b. MO is shown on line 252, $\overline{\text{M8}}$ is on line 253 and $\overline{\text{M10}}$ is on line 254. Referring to FIG. 5b, it is seen that these operations respectively call for flag, keyboard and wait operations. For example, whenever a flag operation is required, the $\overline{\text{MO}}$ instruction must be present, and likewise for the other operation fields.

The M fields MO-M15 are further decoded to generate a constant on lines 225-228 which may be jammed into the adder 55. DMSK representing a digit mask is generated on line 278 from line 256 which also is communicated to edge detector circuitry 255 for detecting the edge of any digit mask, utilized in the carry/borrow circuit and BCD corrector control 59. $\overline{\text{DMEDGD}}$ or digit mask edge delayed is communicated on line 274 to coupling circuitry between the adder 55 and register R5 for controlling entry into R5 as will subsequently be discussed. CBRS or carry/borrow reset is generated on line 273 to prevent a carry out of one digit field into the next digit field in the adder. ANYDMD or any digit mask delayed is generated on line 275 responsive to the I_{12} bit in combination with a decode of the M fields and coupled to the R5 register so as to control and stop recirculation of the data in R5. The I_{12} bit and the mask decode which generates ANYDMSK insures that only during an instruction in which a digit mask is generated will the contents of R5 not recirculate so as to be under control of the R5 control circuit 66.

The loads 256 of the digit mask PLA 83 is shown to be clocked by P_2 and O_1 respectively. This is an important feature of this invention as substantial power reduction is achieved by activating the loads and therefore drawing power only during that part of the cycle when an output is required. Loads 256 are conventional P-channel depletion load MOS devices, heretofore well known but not used in the calculator art. The depletion load devices 256 are implemented using state-of-the-art ion implant techniques. As will be seen with respect to the R decode matrix 73, the loads may also be clocked so as to be operable only during a specific S time, for providing an optimum power dissipation state. Earlier techniques have been utilized in reducing power dissipation in PLA's not having depletion load devices which gated the V_{DD} power directly to the array, requiring additional components and a less desirable power dissipative condition.

The instruction word is communicated from the digit mask PLA on line 251 to the R decode matrix 73 where

it is entered into a 5-bit shift register 257. Bits I_0 - I_2 ripple out of register 257 leaving bits I_4 - I_7 to be decoded. It is seen that loads 258 in the R decoder are clocked with the \bar{S}_0 signal so that the decoded outputs on lines 259 will be valid only during time S_0 . Bits I_4 - I_7 are communicated to the keyboard input circuit for use in the K comparator as earlier described. Other outputs from the R decoder 73 include shift right, shift left, SUB and SUB, and R5 to adder control and the register operation commands of FIG. 5b, controlling the interconnection of Regs. A-D, the constant, R5 and the adder.

The I_0 - I_2 bits ripple out of register 257 into the sigma decoder 74 on line 260. The 3-bit shift register 261 stores bits I_0 - I_2 and the PLA provides the register select exchange and recirculate controls to the main registers as shown in FIG. 5b. Also an I/O command on line 262 is generated for controlling input and output through I/O circuit 82.

The instruction word also is communicated to the D/S test and flag mask comparator 68 on line 251. A 4-bit shift register 263 stores bits I_4 - I_7 while bits I_0 - I_3 are propagated by line 264 to the flag decode PLA 76. Bits I_4 - I_7 as the output of register 263 at time S_{15} are compared by gate 279 with encoded state times on lines 318a from the push/pull matrix 51. Complex gate 265 provides an FMSK output signal indicating that a particular flag mask is to be generated at that S time during an MO flag operation. For example, upon an M10 wait operation, then either a clear flag A command on line 266 or a clear flag B command on line 267 from the flag decode PLA 76 generates FMSK. Likewise, upon an MO or flag operation command, then whenever the encoded state times, which are 2 state times in advance of the actual state times as generated by commutator 51, match the code of I_4 - I_7 as indicated by gate 279, then FMSK is generated indicating which bit of the particular flag is to be acted on. This identification of the S time on line 280 and the FMSK signal via line 268 is communicated to the flag test and comparator circuit for enabling testing and comparing of the flags. The output of the flag test comparator at gate 270 is coupled via line 269 to the condition circuit 118 indicating the result of the test or the compare of the respective flag.

The instruction word rippling out of the flag mask comparator 68 on line 264 enters a 4-bit shift register 271 wherein bits I_0 - I_3 are stored. At time $S_{15}P_1$, the I_0 - I_3 bits are gated into the flag decode PLA 76 for generating various commands such as set idle latch, clear Flag A, clear Flag B, and the other F0-F15 commands as shown on FIG. 5c. As above noted, the flag test and compare circuit gate 270 providing an output on line 269 to the condition circuit is responsive to many of the decoded flag commands.

The flag, digit mask, sigma, and R field PLA's are all similar to the respective PLA's utilized in copending patent application, "Variable Function Program Calculator", Ser. No. 255,856, filed May 22, 1972. The PLA's in the referenced copending application, however, are not responsive to locally decoded instruction words, and do not have clocked depletion load devices on the PLA's, features found only in this invention.

Thus, the decoding of the instruction word in this register system is done locally, with various subsets of the instruction word decoded in a plurality of matrices. By utilizing localized decoding, timing of the calculator system is simplified and considerable savings of silicon space is achieved by reducing the length of lead wires

from subsystem to subsystem. In earlier systems, a more centralized decoding required bussing the decoded command to over all parts of the chip.

THE I/O CIRCUIT AND REGISTER 5 (FIG. 8b9)

On pins 22-25 are the Input/Output lines I/O 1 - I/O 8. Under control of the sigma decoder 74 via line 262 and of the digit mask PLA 83 via the ANYDMD control signal on line 272, data is either input or output at pins 22-25. Each respective output line is precharged to V_{DD} via resistor 289 because absent a I/O input on line 262 from the sigma decoder, the input/output circuitry 82 acts as inputs. That is, lines 281 are precharged to a logic 0 and inverted so that absent an actuation signal, a 1 is supplied to gates 290 inactivating the sigma in lines 225-228. Line 287 responsive to the I/O control from the sigma decoder 74 and to the ANYDMD signal from the M mask decoder 83, is normally 0 allowing input through the buffers to 290. However, during an I/O output from the sigma decoder and the occurrence of an edge of any digit mask, gate 283 is driven to a logic 0 causing them to be responsive to the sigma outlines 286 for outputting data thereon to other chips. During this output state, gate 287 causes buffers 290 to become non-responsive to output lines 282. The latch buffers 288 are tri-state buffers, wherein a pair of 1's supplied to the input of the latch causes the buffers to act as output buffers outputting the binary data on lines 282. The third logic state of the latch buffers is where the output loads, or a pair of 0's on lines 284 and 285 as inputs effectively decouples the buffers from the I/O terminals.

Thus, data from other chips may be input through the buffers 82 on lines 225-228 which are coupled to the adder 55 and therefrom may be transmitted into the main SAM registers, into R5, or through R5 into the keyboard register 54, or may be outputted through the I/O pins once again.

Another important feature of this invention is utilization of a fifth 1-bit register, R5, of four digit length coupled to the adder 55 and to the I/O lines. R5 is loaded with the leading edge of any digit mask as under the control of ANYDMD as generated on line 275 from the digit mask PLA 83. Thus, during any digit mask the existing data in the four bits of R5 is prevented from recirculating as line 291 becomes a logic 0 which effectively decouples the recirculate input. Line 275 becomes a logic 1 allowing the existing data to recirculate upon itself. R5 is then under the control of R5 control circuit 66 which generates control signals on line 292 and data inputs on line 293. The R5 control circuit will be discussed hereafter.

Data is entered from the adder 55 into register 5, upon a \overline{DMEDGD} signal. The digit mask edge delayed signal provides an output upon the leading edge of the digit mask, which occurs the S time next to the S time corresponding to the desired field such as decimal point location. Accordingly, the number in the adder 55 representing decimal point location is entered into Register 5 upon the \overline{DMEDGE} command.

Output from Register 5 is effected on lines 294 and 134. $R5\ out_4$ on line 294 is communicated to the decimal point/D comparator 71 where it is entered into a 4-bit register 295. This binary representation of the decimal point location is compared with the encoded D times as generated on lines 296 by the D time generator 67. Upon a match of the proper D time with the decimal point location representation, complex gate 297

actuates the zero suppress circuit 64 and the decimal point output circuit via line 298.

The $R_5\text{out}_n$ output on line 134 is communicated to the keyboard register control circuit 79 where it may selectively be entered into the keyboard register upon a $R_5.KR$ command.

A more complete understanding of the versatility and utility of the Register 5 is realized upon description of the R5 control circuit 66. The R5 input control line 292 is seen responsive to a number of commands, among which are Flag A to R5, Flag B to R5, number to R5 and keyboard register to R5. That is, the keyboard and Flag A and Flag B registers may be dumped into R5 respectively on lines 299 to 301. The number input on line 302 is coupled to the 4-bit shift register 271 of the flag decode PLA 76 which allows utilization of a subset of digits of the instruction word as data. This is an extremely important feature of the invention as it allows otherwise unused instruction word digits to provide data constants which otherwise would have to be generated under software control. This feature is extensively used during the software programming of this invention.

Input S_3 - S_6 on line 303 allows gate 304 to be responsive to the " \overline{DO}_3 "- M_{10} and KR to R5 commands only during state times 3-6. The " \overline{DO} " input from the flag mask comparator 68 does not refer to the DO time, but to the "0" side of the PLA 305. Referring to FIG. 5e, it is seen that during a W1 as decoded from the I_0 - I_3 bits in combination with a " \overline{DO} " generates a \overline{KR} to $\overline{R_5}$ operation. Before gate 304 is actuated, an M10 operation on line 254 is required, a KR to R5 decode at W1 is required, a \overline{DO} is required, and the timing must be between S_3 and S_6 .

THE D TIME GENERATOR

The D time generator 67 comprises a 4-bit shift register 306 connected as a ring counter and with circuitry responsive to S times. By connecting the output line 130 on the first bit of the shift register 306, then the output actually counts backwards in binary. This is desirable because the D times in fact count backwards so as to aid in zero suppression. The counter counts from 15 to 0 and then holds four times per instruction cycle, as there are 16 S times or 16 O_1 - O_2 combinations which shift data through the 4-bit register. The encoded state times are output serially on line 130 to gate 129 where the D times are serially combined with the appropriate K line encode which is communicated to the keyboard register. The encoded D times are output in parallel on lines 296 and coupled to the wait generator 69, decimal point/D comparator 71, and to the D/S and flag mask comparator 68.

THE DISPLAY OUTPUT CIRCUITRY

The zero suppress circuitry comprises latch gates 307 and 308 responsive to outputs from the B and/or A registers. In the embodiment shown, NAND gate 307 for ending zero suppress is coupled to the A1-A8 bits of the A register and is further responsive to the B_n bit of the B register on line 311 and to the decimal point generator on line 312. Gates 307 and 308 are further responsive to timing signals generated by the push/pull matrix 52 for generating start and end zero suppress signals during selected D times. For example, because D times D14, D15 and D1 are not utilized on the display of this embodiment, and because zeros are desirously suppressed during the exponent digits in the S_1

and S_2 bits, then a start zero suppress signal causes zero suppression on line 322 during D times D_{14} , D_{15} , D_0 , D_1 and D_2 . Since the start zero suppress signal on line 322 is gated into the zero suppression circuitry according to the strobe generator, only when the S times align with the D times, then effectively the S_{14} - S_2 bits are suppressed as desired. An end zero suppress signal on line 321 at time S_3 is desirable because S_3 is the least significant digit in the data word, and a zero is there desired in the display rather than having a blank display. Accordingly, zero suppression is ended during S_3 which means during the D3 strobe of the display.

Line 311 is responsive to the B_n bit of the B register which is selectively set so that zero suppression will be ended after depression of the EE or enter exponent key. For example, by placing 1's selectively in the B_n register, then after an EE function is commanded by the calculator operator, a pair of zeros will be seen on the display instead of a blank display.

The zero suppress circuit is also responsive on line 312 to the decimal point generator 71 such that after a decimal point has been indicated, zero suppression ends because zeros then become significant after the decimal point.

Operation of the zero suppress circuit in combination with the segment displays and idle latch 156 will now be explained. Absent any commands to the zero suppression circuit, zeros are normally suppressed with the output of gate 307 on line 315 residing at a logic zero causing gate 308 to latch at a logic 1 which is an input to gate 307. Not until a nonzero input is generated on the register outputs on lines 323 will zero suppress be ended. That is, upon a zero generated on line 323, gate 307 provides a 1 output causing gate 308 to provide a 0 output setting the latch for ending zero suppress. Line 315 provides a zero to gate 309 which causes a 1 output on line 316 to be supplied to gate 310. Previously gate 309 in response to a 1 on line 315 during zero suppress has supplied zeros as inputs to gates 310 blanking the display.

The idle latch 156 is coupled as an input to gate 309, which functions to blank the segment display outputs whenever idle latch is in the state indicating a calculating condition. That is, only during "idle" will the display outputs be enabled.

To provide sign indicators, the S_2 and S_{13} bits in Flag A register are set such that when flag information on line 154a/314/313 is strobed into the complex gate 155 during D2 and D13, then the Flag A output on pin 15 is actuated to properly illuminate the sign digits. As earlier explained, idle latch 156 outputs Flag A information at S time rates during the calculating or non-idle state, but emits Flag A at D time rates during the idle state for displaying the sign digits.

The idle latch 156 is set and zeroed on lines 324 and 325 respectively in response to the flag decode PLA 76. The output of the idle latch 156 is then outputted on pin 20 at IDLE. NAND gate 317 responsive to the idle latch 156 is also responsive to a level change at time $S_{15}O_2$ - S_0O_1 so that other coupling chips may be synchronized to the S time. In this embodiment, idle latch 156 is also always set during D time D14 such that there is always a level change on IDLE at $D_{14}S_0$, so that the D times on other responsive chips also are synchronized. This is an important feature of this invention as utilizing such a signal both to convey status information of the arithmetic chip and to convey synchronizing information of both S and D times to other chips provides

substantial savings in pin requirements and silicon area utilized.

The segment decode PLA 63 is responsive to the B and/or A register outputs on lines 326 and provides decoded segment outputs on lines 327 which are communicated under the control of the zero suppression circuit to the segment A-segment G output pins. These outputs then selectively actuate segment drivers supplied externally which actuate the appropriate segments of the digit on the display. It is again noted that load 328 of the segment decode PLA 63 is strobed by signal $S_{14}O_2$, as the PLA only needs actuation during time S_{14} . Load 328 is a depletion load MOS device and such a clocking feature provides substantial power savings.

THE COND CIRCUIT

The condition circuit 80 generates the COND signal for communicating to the SCOM chip that the arithmetic chip has a condition to which the SCOM chip should respond. That is, as earlier explained with respect to the keyboard, upon a keyboard entry and K comparator match, or upon an input on the busy terminal on pin 29, a \overline{CONDA} signal on pin 329 is communicated to the condition circuit. COND enables communication of the 7-bit encoded K line/D time word from the keyboard circuitry to the keyboard register 54. Also, by setting the COND bit in the EXT signal, the SCOM chip knows that the arithmetic chip has a control command waiting.

The condition circuit is also responsive to the \overline{I}_{12} bit of the instruction word where it looks for a zero to reset condition. The \overline{I}_{12} bit on line 330 passes through an edge detector for resetting condition at the transition between a branch and an instruction. Another input to the condition circuit is the output of the flag test and compare generator 66 for indicating the result of certain flag test and compares as earlier explained.

The condition circuit is also responsive to the carry/borrow signal on line 213 and to the carry/borrow strobe circuit on line 331. The C/B STB signal on line 331 enables carry/borrow only at the end of the particular mask the calculator is working on to see if there is a carry out of that digit, or to see if there is an overflow condition so as to indicate to the ROM that overflow condition meaning that the number is too large.

THE SCOM CHIP

On the SCOM chip, the EXT command word is communicated to the add-1 circuit 25 on line 400 and to the branch comparator 33 on line 401. The S_0 gate signal on line 412 allows only the S_0 bit of EXT to be communicated on line 411 and inverted by inverter 413. If the S_0 bit of EXT is a 1 indicating a jam-in or P-Reg function, then inverter 413 provides a 0 to gate 402 allowing the address encoded in the subsequent bits of EXT to pass through gate 402 to NAND gate 405 and into the address register. If, however, the S_0 bit of EXT is a logic 0 allowing a branch, normal increment, or constant ROM memory recall, then a logic 1 is supplied to gate 402 by inverter 413 which dis enables the subsequent bits of EXT. The old address is communicated via line 410 to the add-1 circuit and there the address is incremented unless a "hold" signal appears on line 414. Upon a "hold" condition, the same address is reentered into the holding register via line 415.

If the S_0 bit of EXT is a logic 0, then the branch comparator 33 is enabled, dependent then upon a branch

instruction and a match of "COND". It is dis enabled if a logic 1 appears at time S_0 as inverter 413 then generates a logic 0 to gate 416 via line 406.

The previous instruction word read out of the ROM 20 and communicated through the buffer 27 is communicated via line 417 to the branch comparator. Three latches, 418-420, are responsive to the instruction word on line 417 so that the appropriate bit condition will be saved until the EXT command word is subsequently compared therewith. For example, latch 418 had previously been enabled at time S_{14} via line 421A so that the COND bit of the instruction word would appropriately set latch 418. Then upon the subsequent S_1 , the COND state of latch 418 is compared with the S_1 or COND bit of EXT via gate 416. If a match is generated, then gate 416 enables at time S_1O_2 shifting of the address in the holding register into the address register. The address in the holding register then is a branch address as will subsequently be explained.

Latch 419 is responsive to the S_{15} bit of the previous instruction word which is the branch or instruction bit. Only upon a branch bit in the S_{15} bit of the instruction word may a branch be executed, dependent on a "COND" match. Otherwise, a zero will be supplied via line 422 dis enabling gate 416.

Latch 420 is responsive to the S_3 bit of the previous instruction word which is the add or subtract indicator denoting whether or not to positively or negatively increment the old ROM address by the relative amount entailed in the latter bits of the EXT command upon a branch instruction. The output of the latch 420 is communicated to the adder 32 which controls whether the true or complement form of the previous instruction address is coupled into the adder.

A "hold" instruction at time S_2 is communicated through gated line 423 to the add-1 circuit on line 414 and in inverted form on line 424 to gate 416 for dis enabling the branch.

THE HOLDING AND ADDRESS REGISTERS

The combination of utilizing a holding register 24 and an address register 23 and the concept of realtive addressing is an important feature of this invention. The previous address in the address register which accessed the ROM on lines 425 to cause generation of the instruction word I_0-I_{12} on lines 426 is read out of the address register on line 410 and communicated to the full adder 32. The current instruction word on lines 426 is read into the instruction register 26 in parallel, and then read out of the instruction register serially on line 427. The buffer 27 is responsive to the serialized instruction word on line 427 and is further responsive to line 428 to the chip select output of the ROM 20. Upon a proper chip select output on line 428, the buffer 27 is actuated allowing the current instruction word to be read out onto line 430 which is communicated via line 417 to the full serial adder during S times S_3-S_{13} as generated by the S counter 38 and communicated on line 431. The number contained in the I_1-I_{10} bits, if the instruction is a branch and condition is met, is added to the old address with the sum outputted on line 432. Lines 433 and 434 from the latch 420 control addition or subtraction by appropriately inverting the new address. Line 435 provides the carry or borrow function.

The output of the adder comprising the new incremented address is entered into the holding register 24 via line 436. Only if a branch has been commanded will the new incremented address in the holding register be

gated into the address register 23 on lines 437. If a branch has not been indicated, for example, the branch latch 422 has not been set, then the output of the branch comparator on line 421 will not gate the new address into the address register. Instead, the old address on line 410 will have "1" added to it in the add-1 circuit and the incremented by 1 address will be input into the address register directly on line 415.

The holding register feature of this invention provides a one instruction word savings over a similar system not featuring such a holding register. That is, it enables execution of relative addition or subtraction before actual knowledge of whether a branch is to be executed or not. Because the branch bit is I_{12} and the branch address locations are stored in I_1 - I_{10} , storage of this address bits is required before determination of a possible branch operation. Otherwise, a subsequent instruction word after the branch bit would be required.

The new instruction word is selectively transmitted through the output buffer 27 as above described. The C.S. signal or chip select signal on line 428 controls whether or not the addressed instruction word is transmitted. That is, if there are other instruction memories in the system, such as referring to FIG. 2, the ROM memory 12, then the chip select line 428 would enable buffer 27 only when the main ROM had been addressed. Conversely, when another instruction ROM had been addressed, then output buffer 27 would not allow the addressed instruction word from the main ROM to be transmitted, but would allow entry of the proper instruction word to be executed.

Upon transmission of the instruction word from the buffer 27, then the new instruction word is communicated not only to the branch comparator and full adder and arithmetic chip as above described, but also it is communicated on line 438 back into the instruction register 26 for decoding. Such a multiple use of the instruction register in combination with the output buffer is a feature of this invention which saves the requirements of an additional register and allows several instruction memories to be connected in parallel with only a selected one accessing the instruction register for further decoding. After the instruction word from the selected instruction memory has been serially reentered into register 26, then it is communicated via lines 439 to decode PLA 28. PLA load 440 is gated by the O_1 clock signal to reduce power dissipation.

The output of the decode PLA 28 on lines 441 generates the store and recall functions on lines 442 for registers F and G. Also generated is a recall constant command on line 443 utilized for enabling the address circuitry of the constant ROM 35.

The constant register address 34 comprises a 7-bit shift register 445 responsive to the EXT signal on line 444. During S times S_3 - S_5 and S_7 - S_{10} as supplied on line 446, the 7-bit shift register is loaded up to generate true and complement chip select output signals on lines 447 and constant A-constant D signals on output lines 448. The six chip select output lines 447 in addition to the recall constant enable on line 443 actuates NAND gate 449 for generating a recall constant signal on line 450 which enables the constant ROM to be addressed by the constant A-constant D signals. The recall constant signal on line 450 is outputted at time $S_{15}O_1$, and the constant A-constant D signals on lines 448 are propagates at time $S_{14}O_1$.

The constant ROM 35 comprises 16 constant registers with each constant containing 16 digits, and each

digit comprising four bits, so that the constant ROM comprises a $16 \times 16 \times 4$ bit matrix.

The constant ROM is a feature of this invention providing up to 16 predesigned 4-bit by 16-digit constants, and the ROM is advantageously implemented featuring virtual grounding. Virtual ground ROM's have heretofore been known in the calculator art, and are advantageously implemented for substantially reducing the required size of the ROM by eliminating all but 1 V_{SS} line per bit, or a total of 4 V_{SS} lines for the 16-digit by 4-bit constants.

Referring to FIG. 9c each row line 468 of the virtual ground ROM is responsive to a respective S time so that upon "recalling constant" all 16 bits are read out responsive to times S_0 - S_{15} . That is, each cell 458 of the constant ROMs comprises a single transistor having its gate either coupled or decoupled from the respective row line. If a gate is connected, then a logic 1 is stored in the bit, and if the gate is not connected, then a logic 0 is stored therein. The source terminal of the transistor of each cell is either connected directly to V_{SS} or circuit ground on line 460 or is coupled thereto by the virtual grounding arrangement. The drain terminal of the cell transistor is coupled by a column line 459 to the adjacent cell transistor which is coupled to the output line 462 via an appropriate actuation of address transistors 464-467. Each V_{SS} line 460 is decoupled from circuit ground by gate 461 during precharging of the column lines.

Operation of the constant ROM is as follows: V_{SS} or circuit ground is coupled to lines 460 through gate 461 during every 01 and 02 time, as supplied by arrangement 472. During time P2, gates 461 decouple lines 460 from circuit ground, and the output lines 462 are precharged through gates 463. Upon a recall constant command on line 473, a coded address on lines 478 selectively actuate the address transistors 464-467 so as to select a particular column line which is precharged to V_{DD} , and a particular row line 468 is actuated through gate 471. By actuating a particular row line during an S time and by actuating a column line as determined by the particular constant A-constant D address on line 448, one particular cell per bit is addressed. Output line 462 responds accordingly as to whether or not the precharge is discharged through the selected cell transistor, which is determined by the presence or absence of connection to the particular row line 468.

The virtual ground ROM feature of this invention renders the source terminal of the selected bit transistor to be effectively grounded, as ground line 460 is selectively coupled to that source terminal through a particular combination of address transistors 464-467. As above mentioned, only one V_{SS} line per bit is thus required maximizing packing density of the memory cells.

During time O2 the bit of data on output line 462 is coupled through gate 470 when gate 469 is actuated by the recall constant command on line 442. By repeating this sequence for all 16 S times, a 16 digit 4-bit constant is recalled through the IO buffer 455 to the IO lines.

THE F AND G REGISTERS

The F and G registers are implemented in a sequentially addressed memory or SAM format similar to the A-D registers. S times S_0 - S_{15} on lines 451 drive the read address and write address row lines, while the columns 452 are input lines and the columns 453 are out-

put lines. As with registers A-D the F and G registers are interleaved with the columns respectively comprising the F1-G1, F2-G2, F4-G4 and F8-G8 bits. Store \overline{F} and store \overline{G} signals on lines 442 selectively address the complex gates 454 so as to enable the proper bit of the proper register to accept input data on lines 456.

Column lines 453 are selectively coupled to the output buffers 455 so as to communicate the contents of the respective F and G registers through the I/O pins 3-6 in response to the recall \overline{F} and recall \overline{G} commands on line 448. Only if a recall command is generated on line 450 will the contents of Registers F and G be allowed to exit through the buffers. Output buffers 455 are tri-state buffers providing logic 1's and logic 0's in a conventional manner and providing a floating third logic state allowing use of the I/O pin as an input. Gate 457 responsive to the recall \overline{F} , recall \overline{G} and recall constant command provides the proper input to the buffers 455 so as to drive it into the appropriate state for recalling data through the buffers as outputs.

THE MAIN ROM AND DECODE CIRCUITRY

The main ROM 20 is implemented in a virtual grounding configuration which advantageously requires only one V_{SS} or ground line per pair of instruction bits. That is, output lines 473 couple the respective bits of the instruction word 10-112 from the main ROM 20 into the instruction register 26. Each of the output lines 473 is responsive to 8 column lines 474 which are selectively coupled together via serially connected decode transistors 486-488 and further coupled to a shared V_{SS} line 475 instead of conventionally providing one V_{SS} line 475 per column grouping. This provides a considerable increase in packing density.

Each cell of the ROM 20 comprises a single transistor having its gate either coupled or decoupled from a row line. A logic 1 is generated if the gate is connected and a logic zero is generated if the gate is not connected. The horizontal row lines 489 are selectively actuated via decode circuitry 21 which is responsive to the A0-A6 digits of the address word on line 425. The decode arrangement 21 is tree-type wherein each input combination on lines 425 actuate a unique row line 489.

The column lines 475 are selectively chosen in response to the A7-A9 digits of the address word, and the selected columns are also coupled to the respective V_{SS} line 475 to implement the virtual grounding technique.

The A10-A12 digit of the address word are coupled to timing circuitry for generating signals to the input gating circuitry 22 for allowing the address word to be entered into the ROM 20 and into the decoder 21. Bits A10-A12 also are logically coupled together to generate the chip select (CS) signal on line 483. As earlier stated, up to 8 SCOM and ROM chips may be coupled together in this system, and the CS signal on line 483 enable the respective output buffer 27 on each chip so that the instruction word from only the selected ROM is entered into the instruction registers 26 of the system.

Operation of the main ROM 20 is as follows. The address word A0-A12 is impressed on line 425 and 428 as inputs to the input gating circuitry 22. The S1-P1 timing signal on line 490 actuate timing circuitry to generate timing signals $\overline{S102}$ on 481, $\overline{S1P2}$ on line 480, and $\overline{S201}$ on lines 491 and 482. Also, at time S1-P1, all lines of the input gating circuit 22 is discharged to V_{SS} via line 479. This supplies logic zeros on lines 492 for coupling all columns to the output lines 473 so that all

column lines as well as the output lines are precharged at time S101 through gate 477. V_{SS} is decoupled from the V_{SS} line 475 as a gating signal on line 482 is not generated until S1-O1 which prevents short circuiting the precharge voltage.

After all columns have been precharged, then at time S102, the addresses of A0-A9 are read into the gating circuitry and at time S1P2 digits are read into the respective decoding circuitry for selecting the desired column line 474 and coupling it to the output line 473 and to V_{SS} . A0-A6 bits then select the desired row line 489 so that only one cell of the main ROM per digit is read out onto the output line 473.

In this manner, a high-density, low-power consuming ROM is provided for storing up to 1,024 instruction words. Only one V_{SS} line is required per pair of instruction word digits which minimizes the amount of silicon space required for ground lines and thereby maximizes packing density. Precharge techniques utilizing gated V_{DD} and V_{SS} signals allow high-speed ROM operation. The inclusion of bits of the instruction word so as to specify which ROM of the system has been addressed provides the ability of coupling a plurality of ROMs in parallel, and selecting only one instruction word from one of the plurality for execution by the calculator.

Table II depicts a ROM code as stored in hexadecimal format in the main ROM 20.

THE S AND D GENERATORS

The S times on the SCOM chip are generated in the S counter 38 in response to synchronization signal \overline{idle} communicated from the arithmetic chip. Every 16 S times \overline{idle} is programmed so as to change logic state from a logic 1 to a logic zero at a predetermined S time for synchronizing counter 38 with the S times on arithmetic chip. In this embodiment the S time is chosen at S0 and edge detector circuit 512 detects the level change and transmits a logic zero on line 494 into the counter. The counter has coupled to its output the decoder 495a for generating timing signals for a certain S time duration and also for generating on line 513 a logic zero for recycling the counter. That is the decoder 495a is a PLA wherein a gate is implemented on the SOP1 line to the S13P1 line and then on the S15P1 line. For every S time during which a logic 0 is impressed upon one of the gates of line 514, line 514 is a logic 1 and line 513 provides the logic 1 back into the counter. However, at time S14 line 514 becomes a logic 0 causing a logic zero to be fed back on line 513 into the counter generating the 0 at the S15P1 time and providing on line 493 a logic 0 to begin the new cycle of S times during the next D time.

Another embodiment of the S generator eliminates the logic zero feedback in the counter so that the S generator on the SCOM is entirely slaved to the S times on the data chip. That is, the \overline{idle} condition occurring every instruction cycle or D time also initiates counting of the non-freerunning S generator.

On line 515 of the decoder are seen gates at times S3-S15B which is the period required to read the instruction word serially out of the instruction register. On line 516 is generated the S4-S13 state for enabling the adder 32, the branch comparator 33, and the add-1 circuit 25. Programmable contacts 498 are selectively implemented on line 495 during S times S3, S5, and S7-S10 for loading 7 bits of the EXT word into the constant register address 34 for generating the recall constant signal on line 450 and for generating the constant

A-constant D signals addressing the constant ROM.

Idle on pin 7 is also communicated on line 499 to a second edge detector circuit utilized in synchronizing the D SCAN generator 39. Gate 517 selectively activates gate 503 providing a logic zero on line 504 which activates selected sets of transistors 505 and 506 respectively shown coupled to V_{DD} and to circuit ground. For the embodiment chosen, all upper gates are connected and only one transistor 506 has its gate connected. These forces that particular D output to a logic 1 for synchronizing the counter.

Idle is programmed on the arithmetic chip to change logic states not only at a particular S time, but also at a particular D time, such as D14. Line 499 goes from a logic 1 to a logic 0 at SOD14 and line 502 is its complement. Line 501 provides the level change to a logic 0 at time S002 of the next D time, so that all lines 500, 501 and 502 are a logic 1 at time S14P1 of the D14 instruction cycle. This signal actuates line 504 at time S1501. Line 504 then drives the output connected to V_{SS} of the selected stage of the counter 508 to a logic 1 which is coupled into logic NOR gate 509 at S1502. The counter 508 in the D generator is thus ready to provide an output on the D13 line at PIN27 at SOD13 of every instruction set. Accordingly, the D-SCAN generator 39 is synchronized to the D times of the arithmetic chip in response to a level change on the idle line.

Counter 508 in the D-SCAN generator circulates logic zeros with line 510 providing a logic 1 back to the D15 beginning state of the counter at all times except during times D0. The output of the D0 stage of the counter 508 at line 510 has no gate so that a logic 0 is

provided on line 518 back into the D15 stage to begin a new instruction set. The D0-D15 output on pins 1-14 are coupled to the display and into the keyboard for respectively strobing each in a timed sequence.

THE GATE CIRCUITS

Referring now to FIGS. 10a-10r detailed views of the inverters, NANDS, NOR, and complex gates using depletion loads in FIGS. 8 and 9 are shown. FIGS. 10a and 10b are static and dynamic NAND gates, FIG. 10c is a boot-strap NAND gate, and FIG. 10d is an open drain-no load NAND gate. FIG. 10e is a boot-strap type NAND gate while FIGS. 10f, g and h are static dynamic and open drain NOR gates. FIGS. 10i, j, k and l are inverters of the static dynamic boot-strap and open drain types respectively. FIGS. 10m-10r are complex gates using only one load. Depletion load MOS devices are well-known in the art and have well-known IC.

A plurality of novel features have above been described in implementing a high-speed, low-power calculator capable of battery operation and also which provides increased instruction and data storage capacity for complex applications. Although the calculator system of the invention has been described with references to a specific embodiment, various modifications as well as other embodiments of the invention will become apparent to persons skilled in the art. It is therefore contemplated that the appended claims will not be construed in a limiting sense and will cover any such modifications or embodiments as fall within the true scope of the invention.

TABLE II

ROM CODE START END		OBJECT CODE IS 13 BITS									
000	010	TMC501	0A01	0A0F	0A2F	01D8	01D7	0A0A	1002	00B8	
011	021	TMC501	1A70	0081	1A68	1BAE	1A56	0081	1A5E	1C06	
022	032	TMC501	1940	1876	00B1	193C	183F	00A0	1008	0023	
033	043	TMC501	00D1	0123	1BD0	00D1	0ED4	003A	002A	0083	
044	054	TMC501	1892	0D09	0082	0030	1306	0940	072C	1805	
055	065	TMC501	1D06	00C1	1E58	1B02	19A8	1B6C	1D92	183A	
066	076	TMC501	19AC	1853	19AA	1B42	183C	1859	1859	1B4E	
077	087	TMC501	00D1	1B38	0AF0	08BF	00D1	136E	0AF0	08BF	
088	098	TMC501	0126	0A06	02F6	0024	0034	04D0	1B4A	0082	
099	0A9	TMC501	1BE6	1A86	1827	1A8E	1A8C	1AEC	00D1	1827	
0AA	0BA	TMC501	1A66	1AD2	1AE2	1C56	00D1	0ED4	0E23	0C94	
0BB	0CB	TMC501	0060	1808	00B1	0055	0065	0A0D	1873	0051	
0CC	0DC	TMC501	0AF0	0A09	0820	1007	0068	180E	0A0A	0AB5	
0DD	0ED	TMC501	181B	0A01	0A85	0A95	0AA5	180E	01DE	00DA	
0EE	0FE	TMC501	1104	00B1	0139	00A5	0A17	0A18	0A16	02F4	
0FF	10F	TMC501	1806	0A0F	0121	04D4	1880	00B8	1808	01D8	
110	120	TMC501	095B	095B	095B	0989	1822	0AA7	02F3	0289	
121	131	TMC501	0640	065B	0680	0058	01DB	0030	1006	0709	
132	142	TMC501	000F	1976	0A1F	01D0	00B0	1806	0A3F	01D0	
143	153	TMC501	00D1	185E	0071	0091	00F9	0001	00F0	180E	
154	164	TMC501	02F0	01D7	0103	000F	0120	0094	0074	0004	
165	175	TMC501	0A87	1804	0AC7	0A18	04D0	00BA	0640	121E	
176	186	TMC501	104E	0709	1804	0032	0308	0409	1818	0300	
187	197	TMC501	0940	0030	1010	1806	0030	180A	0708	182F	
198	1A8	TMC501	0FED	0708	100C	0FD8	1008	01D8	0022	0032	
1A9	1B9	TMC501	00E1	19F7	0012	19C0	00D0	0A0C	0085	0A0D	
1BA	1CA	TMC501	0940	00B9	18EE	0A06	0A02	00CA	0007	0030	

ROM CODE START END		OBJECT CODE IS 13 BITS									
000	010	TMC501	1176	00CA	00B9	0085	19BA	0308	1B92	0110	1B7A
011	021	TMC501	1A4E	0081	1A54	1D62	18D0	1BEE	1CDA	1A40	183D
022	032	TMC501	002B	1930	0033	00A1	00BA	0059	19E8	1D4E	1F72
033	043	TMC501	180F	19E0	1C4E	00D1	01D8	0A67	0A18	0022	0CC0
044	054	TMC501	159A	00D1	186E	0051	1B88	00D1	1C74	1850	00D1
055	065	TMC501	1E4A	00C9	00A2	18AB	19BA	19A4	199C	192E	1831
066	076	TMC501	1853	1832	1863	1863	1B46	1D5C	1EFC	1ADC	196E
077	087	TMC501	1004	0081	0A77	0A18	1ED4	0083	0130	000F	0080
088	098	TMC501	18B3	1BF6	181B	1BF0	1B02	1A8A	1830	1AFC	1AA6
099	0A9	TMC501	1EB0	1A74	1914	18AB	1A92	18A5	1A78	1841	1A68
0AA	0BA	TMC501	0F94	0039	0081	18F9	00B5	00B0	1806	008D	0095
0BB	0CB	TMC501	00F6	00Fa	03D3	0309	1808	00B8	00C8	1804	0489
0CC	0DC	TMC501	0A10	0A01	1804	0A09	0AE0	0820	1815	0AE0	0820
0DD	0ED	TMC501	0A85	0AA5	110E	190A	0CD8	00DA	1832	0A55	00BA
0EE	0FE	TMC501	0007	187B	0639	00D1	1874	00B0	1808	0A2F	0121
0FF	10F	TMC501	0A02	00BA	0A85	1036	0A08	0EF3	0653	00A0	1024

TABLE II—Continued

ROM CODE START END		OBJECT CODE IS 13 BITS									
110	120	TMC501	181A	00c8	1804	0300	0940	09DB	0C53	0980	180A
121	131	TMC501	10CD	071B	10D1	00D1	0D09	120A	0011	1B50	0133
132	142	TMC501	0007	195D	07D6	03D6	00D9	1941	0A06	02F0	01D7
143	153	TMC501	0090	01D8	0022	0032	1804	0ED0	0104	0084	0A06
154	164	TMC501	0000	1835	0A0D	0A0C	0085	0A47	0090	180A	0070
165	175	TMC501	0015	0A0D	00B8	1808	0026	0036	0120	0D09	00AA
176	186	TMC501	180A	0300	0E09	1814	0940	0409	100B	0E09	1834
187	197	TMC501	06D8	0033	0700	1837	00A8	1004	0069	0030	1808
198	1A8	TMC501	00B8	04D0	1008	0104	002E	003E	0010	180C	00E0
1A9	1B9	TMC501	188F	0948	0308	0948	0308	00B8	100C	0B00	0948
1BA	1CA	TMC501	1006	0948	0308	0058	100E	0103	0D09	1375	0709
ROM CODE START END		OBJECT CODE IS 13 BITS									
1CB	1DB	TMC501	1812	0032	0509	1955	0309	1159	0948	0308	
1DC	1EC	TMC501	00C0	0060	0053	1804	0081	00B0	1808	0ED3	
1ED	1FD	TMC501	0023	0082	003C	1826	068C	1015	0030	1808	
1FE	20E	TMC501	10BE	0989	1017	0988	1862	0030	1039	0684	
20F	21F	TMC501	1AE1	00C3	00A9	00C0	0052	0081	0133	000F	
220	230	TMC501	180E	0989	1020	0069	0022	0ED0	1B33	0033	
231	241	TMC501	1820	0049	0010	1008	0A0D	0A04	0A0D	0048	
242	252	TMC501	06DC	0D29	1023	0080	182A	0082	06DB	1804	
253	263	TMC501	0D09	1813	0300	1817	096C	0D29	104D	0948	
264	274	TMC501	0041	0020	0030	1806	0069	0022	0030	0D09	
275	285	TMC501	032C	180F	0940	0E09	1005	0106	0134	0ED3	
286	296	TMC501	13CF	0126	0103	0623	18B5	0023	0D09	10D3	
297	2A7	TMC501	181E	0C89	100A	0C88	0724	1809	1012	032C	
2A8	2B8	TMC501	18ED	0033	0023	18F3	0C40	1813	0C48	072C	
2B9	2C9	TMC501	0C8B	0031	0724	1115	00A2	0620	0C14	183C	
2CA	2DA	TMC501	0140	0910	1C7F	0106	0A06	02F6	0114	0120	
2DB	2EB	TMC501	0028	1804	0069	0148	0022	0203	0148	06DC	
2EC	2FC	TMC501	0C23	0A08	02F4	032C	00A0	1056	0CC8	1852	
2FD	30D	TMC401	0C5B	183C	0C83	0A0C	0144	0214	0164	01D8	
30E	31E	TMC501	1010	0C80	1807	0C48	0C5B	0E00	0308	1811	
31F	32F	TMC501	19A5	1055	0060	1804	00D1	0030	0D09	180C	
330	340	TMC501	0ED3	180C	0E09	180E	0CD2	180E	095B	0708	
341	351	TMC501	0CEC	182E	0CE4	181A	0A65	0A04	1036	00B0	
352	362	TMC501	182D	0C48	0C7E	0E00	0C5B	1837	0C48	032C	
363	373	TMC501	188E	0C26	01DC	1804	0F24	0C88	1805	0C80	
374	384	TMC501	0A06	0030	0007	0CC4	1004	0C9B	00C0	1823	
385	395	TMC501	0A0D	00B0	10AA	0A97	0A18	008D	0095	0A0D	
396	3A6	TMC501	0CCC	101C	0CC8	00C0	1010	0023	0A57	0A18	
3A7	3B7	TMC501	0C8C	0CD8	18F3	04D4	0CD8	032C	0C48	052C	
3B8	3C8	TMC501	1804	0F36	0CB0	0F0A	11E3	00A9	0031	0CD5	
3C9	3D9	TMC501	0E09	1806	0C40	0308	06D8	0E09	0C14	1010	
3DA	3EA	TMC501	0700	181B	0A75	0AB7	14ED	0045	0A0D	0030	
3EB	3FB	TMC501	00D1	008D	01D8	01C0	0022	0032	1F6F	0F01	
3FC	3FF	TMC501	02F6	1F93	0ED6	1F97					
ROM CODE START END		OBJECT CODE IS 13 BITS									
1CB	1DB	TMC501	180D	0030	1B91	0948	0708	1821	0081	00C3	0052
1DC	1EC	TMC501	002A	003A	0050	1008	0CD2	0024	0034	0080	1804
1ED	1FD	TMC501	0CD2	0024	0034	072C	1006	095B	1807	01DC	002C
1FE	20E	TMC501	105A	0D09	1821	1029	0A06	02F0	01D7	0201	0007
20F	21F	TMC501	1808	0CD2	0024	0034	0050	10C3	0080	1814	0D09
220	230	TMC501	0114	0903	002C	0022	1004	0021	003C	181E	0680
231	241	TMC501	004A	198D	1151	0033	06D2	0689	1007	0688	09D8
242	252	TMC501	0D00	0C9C	1805	0C94	1938	0E09	183B	0C5B	0940
253	263	TMC501	052C	100B	0980	1807	0948	095B	0E00	0308	1811
264	274	TMC501	1312	072C	180E	0329	1010	0509	1004	0069	0948
275	285	TMC501	0729	1004	095B	099C	0E29	180A	0964	0F01	072C
286	296	TMC501	008D	01D8	0CC3	0920	0030	1038	09DC	016C	0729
297	2A7	TMC501	1026	0C64	0E09	1014	0C5B	0D29	101B	0020	0032
2A8	2B8	TMC501	1805	06DC	0CD2	0E09	1806	0C53	0C40	0020	180A
2B9	2C9	TMC501	0C83	0E2C	1805	0C64	0C48	0F09	180B	0140	0210
2CA	2DA	TMC501	0919	0939	1A42	0D09	146F	0036	0D09	00A1	1061
2DB	2EB	TMC501	008D	0A04	0CD8	00A0	100A	0C20	0ED4	00A0	1012
2EC	2FC	TMC501	0CC0	1813	0A04	0A75	1819	00A0	1871	0C23	0C1B
2FD	30D	TMC401	01C0	0030	1006	0C8B	1806	072C	0021	0CD2	072C
30E	31E	TMC501	0E09	1806	0C40	0300	06D8	19D1	032C	1841	0C91
31F	32F	TMC501	06D8	1804	0C48	072C	1805	00B0	18DE	01DC	0030
330	340	TMC501	1805	06D8	0A07	0A18	0C06	0A08	02F4	00B0	1032
341	351	TMC501	181B	0C33	182F	0C48	032C	1805	00B0	101B	0CB0
352	362	TMC501	1805	0CD2	0C89	1031	0C8B	0A08	02F4	1829	00B0
363	373	TMC501	18A3	0C64	0C5B	0C19	100F	0C6C	01A3	0060	1804
374	384	TMC501	0020	1827	0022	0CE4	0C98	18CF	0061	0050	159D
385	395	TMC501	0AF0	08BF	1E1D	12BB	0CC8	00C0	0060	1804	0023
396	3A6	TMC501	0CDB	00C0	1804	0022	0CCC	1008	1827	0CD2	0CC0
3A7	3B7	TMC501	1008	0C80	0E24	1809	0C60	032C	1811	0C48	00C0
3B8	3C8	TMC501	1806	0CB8	1237	0E2C	1807	0C64	0C7E	0F29	180B
3C9	3D9	TMC501	0903	09D8	0E29	1B19	0C64	0700	1809	0032	0940
3DA	3EA	TMC501	102E	0709	180A	0F08	0D09	0E00	1022	0069	1E97
3EB	3FB	TMC501	180A	00C0	00D1	14B3	1BA5	00C0	0106	0082	0A06
3FC	3FF	TMC501									

What is claimed is:

1. In a portable electronic calculator system imple-

mented on at least two semiconductor chips, the combination comprising:

47

48

- a. a first cycle timing generator and a first subcycle timing generator on one of said semiconductor chips for generating cycle times and subcycle times thereon;
 - b. a second cycle timing generator and a second subcycle timing generator on the other of said semiconductor chips for respectively generating cycle times and subcycle times thereon;
 - c. means on said one chip for generating the condition signal upon the occurrence of an internal timing condition on said one chip, said occurrence synchronized with said cycle times and subcycle times generated by said first cycle and subcycle generators; and
 - d. means on said other chip responsive to said condition signal for synchronizing said second cycle and subcycle timing generators with said first cycle and subcycle generators.
2. The calculator system according to claim 1 wherein said second subcycle timing generator is non-free-running, and said condition signal initiates each subcycle sequence.
 3. The calculator system according to claim 1 wherein the means for generating a condition signal further comprise monitoring means for monitoring the activity or non-activity of the calculator.
 4. The calculator system according to claim 1 and further including on said one semiconductor chip, means for generating a multi-digit command signal in timed sequence with said subcycle time generated by first subcycle generator, said multi-digit signal having a first set of digits representing internal operating conditions of said one chip and a second set of digits representing a memory address dependent upon said first set.
 5. The calculator system according to claim 4 and further including on said one chip keyboard input means responsive to keyboard signals on a plurality of lines, the occurrence of a keyboard signal at a particular cycle time identifying the particular key, said keyboard input means comprising storage means for serially entering in coded format a representation that a particular keyline has been actuated, and also for entering serially the particular cycle time.
 6. The calculator system according to claim 3 wherein said other chip further comprises an instruction memory having instruction memory addressing means for sequentially providing addresses, said addressing means operatively connected to receive said multi-digit command signal and responsive to a digit in said first set thereof to cause an interruption in the normal sequencing in the addressing of said instruction memory.
 7. The calculator system according to claim 6 wherein the instruction memory addressing means are further responsive to one of the bits in said first set of said command word to cause said instruction memory to be addressed at the location contained in said second set of digits.
 8. The calculator system according to claim 7 wherein said first set further contains a digit representing the status of an internal condition of said one chip.

5

10

15

20

25

30

35

40

45

50

55

60

65

9. The calculator system according to claim 8 wherein said one chip further comprises a tri-state output buffer, operatively connected to receive and to output said multi-digit command signal, said buffer being coupled to said instruction memory and selectively responsive thereto for latching into a state which prevents outputting data from said one chip and permits inputting of data to said one chip.
10. The calculator system according to claim 9, wherein said tristate output buffer is coupled to said keyboard input storage means for permitting inputting thereto when said output buffer is latched into said state.
11. An electronic calculator system implemented in a small number of semiconductor integrated circuit units which contain memory means for storing numerical data and arithmetic means selectively coupled to the memory means for operating on the numerical data, one of the units having first subcycle and cycle timing means and strobing means, responsive to the first cycle timing means for providing strobe signals at predetermined intervals, the system including keyboard input means and including display means which are strobed by the strobe signals, means for generating on said one unit a signal indicative of an internal operating condition of such unit and also having a selected timed relationship with said cycle time and with a subcycle time of said cycle time, means for coupling such signal from said one unit to at least one other unit, and second subcycle and cycle timing generator means on said at least one other unit responsive to said signal indicative of an internal operating condition for generating subcycle and cycle times.
12. An electronic calculator system according to claim 11 and further including on at least one of the units an instruction memory for storing a large number of instruction words, and said one unit further comprising means for unconditionally addressing said memory means by generating a multi-digit command word, said command word comprising a first set of digits representing internal operating conditions of said one unit and comprising a second set of digits representing memory address conditioned on at least one of said first set.
13. An electronic data processing system implemented in a small number of semiconductor integrated circuit units which contain memory means for storing numerical data and arithmetic means selectively coupled to the memory means for operating on the numerical data, one of the units having first subcycle and cycle timing means, the system including input means and including output means which are responsive to timed signals from said first cycle timing means means for generating on said one unit a signal indicative of an internal operating condition of such unit and also having a selected timed relationship with said cycle time from said first cycle timing means and with a subcycle time from said first subcycle timing means, means for coupling such signal from said one unit to at least one other unit, and second subcycle and cycle timing generator means on said at least one other unit responsive to said signal indicative of an internal operating condition for generating subcycle and cycle times.

* * * * *

65